

John D. Rockefeller IV
Governor



L. Clark Hansbarger, M.D.
Director

*Obsolete By
Filed 10-27-83
pg.*

State of West Virginia

DEPARTMENT OF HEALTH
CHARLESTON 25305

NOTICE OF PUBLIC HEARING

Pursuant to Section five, Article three, Chapter twenty-nine-A of the Code of West Virginia, one thousand nine hundred thirty-one, as amended, the Wastewater Division of the West Virginia Department of Health shall convene a public hearing at 9:30 a.m., on April 29, 1983, in conference rooms A and B, 1900 Washington Street, East, Charleston, West Virginia, for the purpose of taking evidence pertaining to the filing of proposed Interpretive Rule 16-1, Series IX, Sewage Treatment and Collection System Design Standards.

Any citizen or other interested party may appear in person to present evidence. Any citizen or other interested party may submit written evidence to the West Virginia Department of Health, Wastewater Division, Room 507, 1800 Washington Street, East, Charleston, West Virginia, 25305, not later than 5:00 p.m., April 29, 1983.

The issues to be heard shall be limited to the actual information contained in the proposed and abovementioned rules. Copies of the rules may be obtained from the Wastewater Division, address heretofore appearing or by telephone 304-348-0578. Copies of the rules may be viewed at the following locations:

Guthrie District Office
4877 Brenda Lane
Charleston, WV 25312

Beckley District Office
c/o Pinecrest Hospital
Area 1-D
Beckley, WV 25801

Philippi District Office
209 S. Main Street
Philippi, WV 26416

Kearneysville District Office
Rt. 2, Box 44
Kearneysville, WV 25430

FILED IN THE OFFICE OF
A. JAMES MANCHIN
SECRETARY OF STATE

THIS DATE 3/28/83
Administrative Law Division

L. Clark Hansbarger
L. Clark Hansbarger, M.D.
Director of Health

OFFICE OF THE DIRECTOR
CHARLESTON, WEST VIRGINIA 25305

Entered

FISCAL NOTE FOR PROPOSED RULES

FILED IN THE OFFICE OF
A. JAMES MANCHIN
 SECRETARY OF STATE

THIS DATE 3/28/83
 Administrative Law Division

Rule No. 16-1, Series IX

Subject Sewage Treatment and Collection Systems

Type of Rule: Legislative

Interpretive

Procedural

Agency Department of Health

Address 1800 Washington Street, East

Charleston, WV 25305

Authorized Representative Robert P. Wheeler

Phone 348-2970

1. Effect of Proposed Rule	ANNUAL		FISCAL YEAR		
	Increase	Decrease	Current	Next	Thereafter
Estimated Total Cost	\$ 0	\$ 0	\$ 0	\$ 0	\$ 0
Personal Services					
Current Expense					
Repairs and Alterations					
Equipment					
Others					

2. Explanation of above estimates.

These changes do not require additional staff or equipment nor do they reduce existing needs. Improvements in performance are expected, while costs are maintained at current levels.

3. Date 3/28/83

Agency Department of Health

Signature of Agency Head

Clark J. ...

Signature of Authorized Representative

Robert P. Wheeler

STATEMENT OF ECONOMIC IMPACT OF PROPOSED RULES OR REGULATIONS

Agency Department of Health

Rule No. 16-1, Series IX

Subject Sewage Treatment & Collection Systems

1. Explanation of Overall Economic Impact of Proposed Rule.

A. Economic Impact on State Government.
Little or none.

FILED IN THE OFFICE OF
A. JAMES MANCHIN
SECRETARY OF STATE
THIS DATE 3/28/83
Administrative Law Division

B. Economic Impact on Political Subdivisions; Specific Industries;
Specific groups of citizens.

Will increase workload of county health departments, with possible increased personnel costs. Will increase initial development costs for some types of housing development. These costs may be offset, however, by a subsequent reduction in the number of public health nuisances and hazards occurring in such developments.

C. Economic Impact on Citizens/Public at Large.

May increase initial costs of some types of housing development resulting in increased lot prices in those cases. Cost may be offset, however, by improved performance of sewage systems and decreased cost of correction and maintenance.

Date 3/28/83

Agency Department of Health

Signature of Agency Head

[Handwritten Signature]

Signature of Authorized Representative

[Handwritten Signature]

Revised 2/23/85

FILED IN THE OFFICE OF
A. JAMES MANCHIN
SECRETARY OF STATE
THIS DATE 3/28/83
Administrative Law Division

PROPOSED

WEST VIRGINIA INTERPRETIVE RULES
BOARD OF HEALTH

Sewage Treatment and Collection System
Design Standards

N O T I C E

The Division of Water Resources, Department of Natural Resources, has been designated by the director to act as the authorized agent of the Department of Health in the review of all EPA-Construction Grants Program projects. This authorization was granted in a letter dated July 10, 1979, in accordance with an Executive Order of the Governor dated June 11, 1979. As the authorized representative of the director, the Division of Water Resources is responsible for the review of all EPA-Construction Grants projects and application of these rules to all EPA-Construction Grants Program projects as long as the aforementioned executive order remains in effect.

Projects designed under the Construction Grants Program may be required to meet general criteria and design parameters more stringent than those found herein due to USEPA guidelines and requirements.

ALL APPLICATIONS, PLANS AND REQUESTS FOR INFORMATION CONCERNING EPA-CONSTRUCTION GRANTS PROGRAM PROJECTS SHOULD BE FORWARDED TO:

Construction Grants Branch
Division of Water Resources
Department of Natural Resources
1201 Greenbrier Street
Charleston, West Virginia 25311

WEST VIRGINIA INTERPRETIVE RULES
BOARD OF HEALTH

Chapter 16-1
Series IX
(1983)

Subject: Sewage Treatment and Collection System Design Standards

Section 1. General

1.1. Scope - These interpretive rules establish the design standards for sewage treatment or collection system construction and operation.

1.2. Authority - These interpretive rules are issued under the authority of Chapter 16, Article 1, Section 7 and are related to Chapter 16, Article 1, Section 9 of the West Virginia Code of 1931, as amended.

1.3. Filing Date - These interpretive rules were promulgated on the _____ day of _____, 19____, and were filed on the _____ day of _____, 19____, in the Secretary of State's office.

1.4. Effective Date - These interpretive rules became effective on the _____ day of _____, 19____.

1.5. Supersession and Repeal - These interpretive rules supersede and repeal interpretive rules 16-1, Series VII, Design Standards for Small Septic Tank Systems and 16-1, Series IX, Permit Procedures and Design Requirements for Small Sewage and Water Systems.

Section 2. Application and Enforcement

2.1. Application - These interpretive rules apply to any person engaged in the construction or operation of sewage treatment or collection systems requiring approval by the department of health under Chapter 16, Article 1, Section 9 of the West Virginia Code of 1931, as amended.

2.2. Enforcement - The enforcement of these interpretive rules is

Board of Health
Interpretive Rule 16-1
Series

vested with the director of the West Virginia department of health or his lawful designee.

Section 3. Definitions - Refer to Sewage System Rules, Chapter 16-1, Series IX.

Section 4. Design Standards for Sewage Treatment and Collection Systems -

Section 4 is divided into nine (9) Parts, indexed and numbered internally by subsections. References to subsections within a Part refer to that Part unless indicated otherwise.

Board of Health
Interpretive Rule 16-1
Series

Part I

SEWAGE PERMIT APPLICATIONS

INDEX

Subsection	Page
1.0 Procedure A--Plants of 100,000 GPD or less.	
2.0 Procedure B--Plants greater than 100,000 GPD.	
3.0 Procedure C--Individual On-Site Systems	
4.0 Procedure D--Subdivisions	
5.0 Revisions to Approved Plans and Specifications.	
6.0 Operation During Construction	

SECTION 4

Part I

SEWAGE PERMIT APPLICATIONS

1.0. PROCEDURE A - Shall be followed in preparing a complete application for a construction permit for proposed sewage collection and treatment works with a capacity of 100,000 gallons per day or less.

1.1. Acceptable Application - Eight (8) copies of application forms, design data sheets, reports, plans and specifications shall be submitted to the Wastewater Division. A check or money order in the amount of fifty dollars (\$50), payable to the State of West Virginia shall be required when the submission is for sewage treatment facilities which have discharge. Cash will not be accepted. Note: A separate application, plans, and other data will be required for any potable water facilities.

1.2. Applications - Application forms and design data sheets may be obtained from the local health departments; State Health Department District Offices; or the Wastewater Division, State Department of Health, 1800 Washington Street, East, Charleston, West Virginia 25305. Assistance in filling out application forms and in preparing the application may be obtained from the local health departments or District Offices when requested.

1.3. Required Information to Accompany Application

1.3.1. Application Forms and Design Data Sheets

1.3.1.1. Completed application form with \$50 application fee if applicable.

Board of Health
Interpretive Rule 16-1
Series

1.3.1.2. Completed design data sheet EG-4.

1.3.2. Required Information to Accompany Application

1.3.2.1. U.S. Geological Survey Topographic Map showing property lines, point of discharge, downstream water intake impoundment, or water recreational facilities, if any.

- A. Layout with dimensions and property lines.
- B. Proposed home sites, mobile home sites, camping trailer or camp sites, schools or other buildings.
- C. Location of/and distances to water intakes or wells.
- D. Location of existing or proposed water lines.
- E. Proposed sewage treatment unit or public sewer line.
- F. Layout and size of proposed sewer lines, manholes and/or cleanouts and location of lift stations.
- G. Distance(s) of proposed sewage treatment plant, stabilization pond, and polishing pond from surrounding residences or other buildings.
- H. Point of discharge of effluent in stream. List mile point, if known.
- I. Effluent routing details.
- J. A six (6) foot minimum high fence around sewage treatment facilities with locked entrance gate.
- K. Twenty-five (25) year and 100 year flood elevation.

1.3.2.3. Profile of proposed sewer, effluent discharge lines and force mains showing:

- A. Existing and finished ground level.
- B. Invert elevations and manhole designation and locations. (gravity only)

Board of Health
Interpretive Rule 16-1
Series

C. Size, length and grade of proposed sewer lines.

D. Water main crossing.

1.3.2.4. Report and specifications setting forth:

A. General description of proposed project and location.

B. Number of units to be served and possible expansion of facility.

C. Type and specifications of pipe and joints to be used. (ASTM)

D. Specifications for proposed sewage treatment plant.

E. Specifications for lift stations.

F. Hydraulic calculations. (TDH, Friction Head, Static Head, Horsepower, Detention and Running times for lift stations)

G. Soil characteristics of site for a stabilization pond, aerated lagoon or polishing pond. Report from U.S. Department of Agriculture, soil conservation service required.

H. Manhole details.

I. If land disposal of effluent is used, information as required in Part 3 Section 15 of this publication is to be submitted.

J. Gravity filter details.

K. Sewer riser details. (Mobile Home Parks)

L. Test Equipment.

M. Waste Load allocation from Division of Water Resources, Department of Natural Resources.

N. Aerated Sludge Holding Tank.

O. Chlorinator.

P. Flow Equalization.

Q. Post Aeration.

Board of Health
Interpretive Rule 16-1
Series

R. Nutrient Removal.

1.3.2.5. Plans of sewage treatment plant, lift station, stabilization pond, aerated lagoon, filter, or polishing pond to be installed.

1.3.2.6. Documentation shall be furnished consisting of:

A. Letter granting permission to connect to public or privately owned sewage collection or treatment system when such is the proposal.

B. Legal document(s) granting permission for right-of-way through adjacent property for installation of sewers or effluent discharge lines.

C. Articles of incorporation of property owners association for developments of less than 25 service connections.

D. Articles of incorporation of a private utility under Public Service Commission to assure adequate operation and maintenance of sewage treatment facilities.

E. Written documentation from the Division of Water Resources, the Department of Natural Resources, granting permission to connect to existing public sewer system which discharges without benefit of acceptable treatment, when such is the proposal.

1.3.2.7. Report From District Engineer -

ALL OF THE ABOVE INFORMATION SHALL BE SUBMITTED IN EIGHT (8) COPIES!

1.4. Size of Plans - Plans shall not be less than 18" x 24" in size, nor greater than 27" x 40". Plan submissions of 10 sheets or less per set shall be folded by sets with the project title showing. Plan submissions consisting of an excess of 10 sheets per set may be rolled. Plans must be of uniform size and stapled together by sets.

2.0. PROCEDURE B - Shall be followed in preparing an acceptable

Board of Health
Interpretive Rule 16-1
Series

application for a construction permit for sewage collection and treatment facilities having a capacity greater than 100,000 GPD will incorporate all requirements in Subsection 1.0 and in addition require the following:

2.1. Design Engineering Report - The following is a recommended format for the engineering report.

2.1.1. Title - Engineering report - Name of sewage works project.

2.1.2. Transmittal Letter - A letter typed on firm's letterhead and bound into a report briefly summarizing findings, conclusions, and recommended action.

2.1.3. Title Page

2.1.3.1. Project Title

2.1.3.2. Applicant

2.1.3.3. Consulting engineering firm

2.1.3.4. Professional engineer's seal and signature

2.1.4. Table of Contents

2.1.4.1. Chapter headings and subheadings

2.1.4.2. List of tables

2.1.4.3. List of figures

2.1.4.4. Appendixes

2.1.5. Information Concerning Scope of Project

2.1.6. Population - Current, design and saturation.

2.1.7. Wastewater Flow and Strength - Hydraulic and organic loading.

2.1.8. Collection System - Immediate needs to implement recommended project, deferred needs to complete recommended project, and pump stations, force mains, appurtenances, etc.

Board of Health
Interpretive Rule 16-1
Series

2.1.9. Treatment Process - Selected process.

2.1.10. Receiving Stream - Existing flow and water quality, classification and wasteload allocations, downstream water uses, and impact of project on receiving streams.

2.1.11. Institution Responsibilities - Administrative capabilities necessary to carry out the recommended project through construction and operation and maintenance of the system.

2.2. Specifications - Complete technical specifications for the construction of sewers, sewage pumping stations, treatment plants, and all appurtenances, shall accompany the plans. The specifications accompanying construction drawings shall include, but not be limited to, all construction information not shown on the drawings which is necessary to inform the contractor in detail of the design requirements including the quality of materials and workmanship and fabrication of the project and the type, size, strength, operating characteristics and rating of equipment; allowable infiltration; the complete requirements for all mechanical and electrical equipment including machinery, valves, piping, and jointing of pipe; electrical apparatus, wiring, and meters; laboratory fixtures and equipment; operating tools; construction materials, special filter materials such as stone, sand or gravel; miscellaneous appurtenances; chemicals when used; instructions for testing materials and equipment as necessary to meet design standards; and operating tests for the completed works and component units.

2.3. Operation and Maintenance Manual - should include the following considerations for preparation:

2.3.1. Introduction

Board of Health
Interpretive Rule 16-1
Series

2.3.2. Permits and Standards

2.3.3. Description, Operation and Control of Wastewater Treatment Facilities.

2.3.4. Description, Operation and Control of Sludge Handling Facilities.

2.3.5. Personnel (Staffing)

2.3.6. Laboratory Testing

2.3.7. Records

2.3.8. Maintenance

2.3.9. Emergency Operation and Response Program

2.3.10. Safety

2.3.11. Utilities

2.3.12. Electrical Systems

3.0. PROCEDURE C - Shall be followed in preparing an acceptable application for and individual on-site sewage collection and treatment system:

3.1. Acceptable Application - One copy of a completed individual on-site application form shall be submitted to the director.

3.2. Application - Application forms may be obtained from the local health departments or State Health Department District Offices.

4.0. Procedure D - Shall be followed in preparing an acceptable application for a subdivision utilizing individual sewage disposal systems.

4.1. Acceptable Application

4.1.1. Four (4) copies of the application forms, design data, reports, plans, plats and documentation shall be submitted to the Wastewater

Board of Health
Interpretive Rule 16-1
Series

Division of the state health department.

4.1.2. Application Forms - Application forms may be obtained from the local health departments, State Health Department District Offices, or the Wastewater Division, State Health Department, 1800 Washington Street, East, Charleston, West Virginia 25305. Assistance in filling out application forms and in preparing the application will be given by the local health departments or District Offices when requested.

4.3. Required Application Forms and Design Information

4.3.1. Completed application form.

4.3.2. U. S. Geological Survey Topographic Map showing property lines.

4.3.3. Plat of the proposed subdivision, drawn to a scale of not more than 50 feet per inch, showing:

4.3.3.1. Number, size, and location of lots.

4.3.3.2. Lot dimensions and lot number or letter designation.

4.3.3.3. Location of roads, driveways, easements, rights-of-way, proposed residences and other physical features of the subdivision.

4.3.3.4. Location of wells and/or public water lines.

4.3.3.5. Location of reserve area for the installation of two approved individual sewage disposal systems.

4.3.3.6. Location of percolation testholes and a six foot observation hole on each lot in the area reserved for the proposed individual on-site sewage system.

4.3.3.7. Results of percolation test and six foot hole together with a site report of inspection by the local sanitarian, district sanitarian, or

Board of Health
Interpretive Rule 16-1
Series

district engineer.

4.3.3.8. Topography of the subdivision showing five foot contour intervals for subdivisions of more than fifteen lots.

4.3.4. Soils report from the Soil Conservation Service detailing soil classifications and characteristics determined from on-site investigation of the area to be developed.

5.0. Revisions to Approved Plans and Specifications - Any deviations from approved plans or specifications affecting capacity, flow, or operation of units shall be approved in writing before such changes are made. Plans or specifications so revised should, therefore, be submitted well in advance of any construction work which will be affected by such changes, to permit sufficient time for review and approval. Structural revisions or other minor changes not affecting capacities, flows, or operation will be permitted during construction without approval. "As built" plans clearly showing such alteration shall be submitted to the state health department and the municipality at the completion of the work.

6.0. Operation During Construction - Specifications shall contain a program for keeping existing treatment plant units in operation during construction of plant additions. Should it be necessary to take plant units out of operation, a shutdown schedule agreed to by the state agency shall be followed.

PLEASE READ THE ABOVE INSTRUCTIONS CAREFULLY AND SUBMIT THE REQUIRED INFORMATION. OMISSION OF ANY OF THE REQUIRED INFORMATION MAY RESULT IN THE APPLICATION BEING DENIED AND RESULT IN NEEDLESS DELAY.

Board of Health
Interpretive Rule 16-1
Series

PRIOR TO SUBMITTAL OF THE PROPOSED APPLICATION FOR A NON-EPA CONSTRUCTION GRANTS PROJECT, A CONFERENCE MAY BE REQUESTED BY CONTACTING THE WASTEWATER DIVISION.

PRIOR TO SUBMITTAL OF THE PROPOSED APPLICATION FOR AN EPA CONSTRUCTION GRANTS PROJECT, A CONFERENCE MAY BE REQUESTED BY CONTACTING THE CONSTRUCTION GRANTS BRANCH, DIVISION OF WATER RESOURCES, DEPARTMENT OF NATURAL RESOURCES.

Board of Health
Interpretive Rule 16-1
Series

SECTION 4

Part II

SEWAGE COLLECTION SYSTEMS

Part II
SEWAGE COLLECTION SYSTEMS
INDEX

Subsection

	Page
1.0 General.	
2.0 Gravity.	
3.0 Vacuum Sewage Collection Systems	
4.0 Pressure Sewage Collection Systems	
5.0 Manholes	
6.0 Pumping Stations	

Board of Health
Interpretive Rule 16-1
Series

1.0. GENERAL

1.1. New systems or extensions to an existing system will be approved to carry sanitary sewage flows plus an allowance for non-excessive infiltration.

1.2. Modifications to existing systems will be approved to carry sanitary sewage flows plus an allowance for non-excessive infiltration and inflow.

1.3. Overflows from interceptor sewers shall not be permitted.

1.4. No new combined system shall be approved.

1.5. Design Factors - In determining the required capacities of sanitary sewers, the following factors should be considered.

1.5.1. Maximum hourly quantity of sewage.

1.5.2. Additional maximum wastewater flow from industrial plants.

1.5.3. Groundwater infiltration.

1.6. Design Basis Per Capita Flow - New systems shall be designed on the basis of either of the following two methods to arrive at average dry weather flows from combined residential, commercial and institutional sources.

1.6.1. Estimates based on fully documented analysis of water use records adjusted for consumption and losses. Minimum one year records analysis is recommended.

1.6.2. State developed per capita wastewater flows for various sizes and types of municipalities.

1.6.2.1. Less than 10,000 population - 70 GPCD.

1.6.2.2. 10,000 to 25,000 population - 80 GPCD.

Board of Health
Interpretive Rule 16-1
Series

1.6.2.3. Planning areas and towns with greater than 25,000 population - 90 GPCD.

2.0. GRAVITY

2.1. Design Period - The maximum allowable design period for sewers will be 50 years for the estimated tributary area. Phasing of collection system will be allowed.

2.2. Infiltration Allowance and Industrial Flows - An infiltration allowance of 200 gallons per inch diameter per mile per day and a reasonable allowance for future industries may be added to the per capita design flows to arrive at the average daily flow (ADF).

2.3. Peak Flows - The sewers should be designed to carry a peak flow, when flowing full, of:

2.3.1. Lateral Sewers - 4 x ADF

2.3.2. Trunk and Interceptor and Outfall Sewers - 2.5 x ADF

2.4. Alternate Method - When deviations from the above stated peak design flows are desired, a brief justification and description of the procedure used for sewer design shall be included in the design engineering report.

2.5. Calculations - Computations and other design data shall be presented in an appropriate form for proposed sewage collection and treatment facilities of greater than 100,000 GPD. These computations shall include average daily flow and peak daily flow at critical points such as change in size of sewers; velocity at minimum, average and peak flows in sewers, as required.

2.6. Minimum Size - No gravity sewer shall be less than eight (8)

Board of Health
Interpretive Rule 16-1
Series

inches in diameter except that six (6) inch diameter sewer pipe may be used for lateral sewers where no possibility of future extension exists and no more than either thirty (30) mobile homes or fifteen (15) residences can be served. Four inch sewer pipe will not be allowed for the collection system.

2.7. Small Diameter-Gravity Sewers - These sewers may be utilized for sanitary sewage collection subject to review on a case by case basis by the director. Pretreatment is required prior to discharge into these small diameter gravity sewers.

2.8. Cover - Minimum allowable earth cover on sewers shall be 3 feet unless otherwise approved by the director. Generally, sewers shall be sufficiently deep to drain basement fixtures and to prevent freezing.

2.9. Slope

2.9.1. All new sewers shall be so designed and constructed to give velocities, when flowing full, of not less than 2.0 feet per second based on Kutter's or Manning's formula using an "n" value of 0.013. For existing sewers, value of "n" is recommended as 0.015 to determine existing capacities. Use of other practical "n" values may be permitted, if deemed justifiable on the basis of research or field data presented by the consulting engineer. The following are the minimum slopes to be provided. Slopes greater than these are desirable.

Board of Health
Interpretive Rule 16-1
Series

<u>Sewer Size</u>	<u>Minimum Slope in feet per 100 feet</u>
6"	0.62
8"	0.40
10"	0.28
12"	0.22
14"	0.17
15"	0.15
16"	0.14
18"	0.12
21"	0.10
24"	0.08
27" and larger	0.07

2.9.2. Under special conditions, if detailed justifiable data is given, slopes slightly less than those required for the 2.0 feet per second velocity when flowing full may be permitted. Whenever such decreased slopes are selected, the engineer must furnish with his report his computations of the depth of flow in such pipes at minimum, average, and peak rates of flow. It is recognized that such decreased slopes may cause additional sewer maintenance.

2.9.3. Sewers shall be laid in a straight line with uniform slope between manholes. Sewers laid on 20 percent slope or greater shall be anchored securely with concrete anchors, or approved equal, spaced as follows:

Board of Health
Interpretive Rule 16-1
Series

2.9.3.1. Not over 36 feet center to center on slopes between 20% to 35%.

2.9.3.2. Not over 24 feet center to center on slopes between 35% to 50%.

2.9.3.3. Not over 16 feet center to center on slopes 50% and over.

2.10. Alignment - Sewers 24 inches in diameter or less shall be laid with straight alignment between manholes.

2.11. Increasing Size - When a sewer joins a larger one, the invert of the larger sewer should be lowered sufficiently to maintain the same energy gradient. An approximate method for securing these results is to place the 0.8 depth of both sewers at the same elevation.

2.12. High Velocity Protection - Where velocities greater than 15 feet per second are attained, special provisions shall be made to protect against displacement by erosion and shock.

2.13. Materials - The material selected for the pipe should be adapted to local conditions, such as character of industrial wastes, possibility of septicity, soil characteristics, exceptionally heavy external loadings, abrasion and similar problems.

2.14. All sewers shall be designed to prevent damage from super-imposed loads. Proper allowance for loads on the sewer shall be made according to the width and depth of trench. Gravity sewer lines shall be constructed of clay, plastic, asbestos cement, cast iron, ductile iron or concrete sewer pipe meeting the following minimum specifications:

2.14.1. House Connection to Collector Sewers:

Clay - ASTM C 700

Board of Health
Interpretive Rule 16-1
Series

Plastic - ASTM D 2729, D 2751, D 2836, D 2852

Asbestos Cement - Class 2400

Ductile Iron - AWWA C-110, C-151, Cement lined

Cast Iron - ASTM A 74

Concrete - ASTM C 14

2.14.2. Collector and Interceptor Sewers:

Clay - ASTM C 700--Joints shall meet the requirements of
ASTM C 425.

NOTE: Slip seal joints or cement joints shall not
be permitted.

Plastic - ASTM D 3033, D 3034

Composite - ASTM D 2680

Asbestos Cement - ASTM C 428, Class 2400

Ductile Iron - AWWA C-110, C-151, Cement lined

Cast Iron - AWWA C-108, Cement lined

Concrete - ASTM C-76

2.15. Bedding - Class "A", "B", "C" in accordance with ASCE Manual &
Report on Engineering Practice No. 37 will be permitted. The class of
bedding shall be determined by the engineer to provide the strength
necessary for the soil and load conditions that will be encountered.

2.16. Inverted Siphons - Inverted siphons should have not less than 2
barrels, with a minimum pipe size of 6 inches and shall be provided with
necessary appurtenances for convenient flushing and maintenance; the man-
holes shall have adequate clearances for rodding; and in general, sufficient
head shall be provided and pipe sizes selected to secure velocities of at

Board of Health
Interpretive Rule 16-1
Series

least 3 feet per second for average flows. The inlet and outlet details shall be arranged so that the normal flow is diverted to one barrel, and so that either barrel may be taken out of service for cleaning. Cast iron pipe or equal shall be utilized.

2.17. Stream Crossing - Whenever sewers must cross under a stream or watercourse, a minimum separation of 3 feet between the stream bed and the top of the sewer pipe shall be provided. However, when sewers cross a stream and less than three (3) foot cover is provided, the sewers shall be encased in concrete for at least 10 feet on either side of the stream. Cast iron pipe or equal shall be utilized.

2.18. Aerial Sewers - Aerial sewers will require prior approval of the director.

2.19. Protection of Drinking Water Supplies

2.19.1. Water Supply Interconnections - There shall be no physical connection between a public or private drinking water supply system and a sewer, or appurtenance thereto.

2.19.2. Relation to Water Works Structures - While no general statement can be made to cover all conditions, it is generally recognized that sewers shall be 10 feet horizontally or more from a drinking water supply.

2.19.3. Relation to Wells - In general, no sewer line shall be located within 50 feet of any well utilized for a public or private drinking water system. However, if physical limitations prevent a 50 foot separation, the sewer shall be constructed and tested as prescribed. Under no conditions shall any sewer be constructed closer than ten (10) feet to a well.

2.19.4. Relation to Water Lines

2.19.4.1. Horizontal Separation - Routinely, sewers shall be laid a minimum of at least 10 feet horizontally away from any existing or proposed water lines. However, if the conditions prohibit a 10 foot separation, the sewer must be constructed and tested as prescribed in Subsection 2.19.5. Under no circumstances shall any sewer be constructed closer than 3 feet edge to edge to a water line.

2.19.4.2. Vertical Separation - Whenever a sewer must cross water lines it should be constructed at such an elevation so that the top of the sewer line is a minimum of 18 inches beneath the bottom of the water main. However, if elevation conditions can not be met, then the sewer shall be constructed and tested as prescribed in Subsection 2.19.5.

2.19.5. Special Construction Requirements

2.19.5.1. Horizontal - In cases where water and sewer lines must be laid closer than 10 feet apart, the sewer line shall be constructed a minimum of 18 inches lower than the water line and constructed of a pressure type pipe meeting requirements for water lines. The installation shall be hydraulically tested for a period of not less than 24 hours and shall be considered satisfactory if leakage is not more than 0.25 gallons per inch diameter of pipe per joint.

2.19.5.2. Vertical - If a vertical clearance of 18 inches as specified in Subsection 2.19.4.2 cannot be maintained the sewer shall be so located that it crosses between joints of the water line. The sewer line shall also be constructed so that it crosses under the water line at mid joint. The sewer shall be constructed and tested as required in Subsection

2.19.5.1. Under no circumstances shall a sewer line be constructed over the top of a water line.

2.20. Sewer Riser Pipes

2.20.1. All mobile home lots shall be provided with a sewer riser pipe having a minimum diameter of 4 inches and extending at least 4 inches above the ground in a vertical position.

2.20.2. All sewer riser pipes when not serving a mobile home, shall be tightly plugged or capped to render them water tight.

3.0. VACUUM SEWAGE COLLECTION SYSTEMS

3.1. Main Lines

3.1.1. Materials

3.1.1.1. PVC or ABS of schedule 40 DWV, Class 200, or SDR 21.

3.1.1.2. Joints may be either solvent welded, "O"-Ring, or heat fusion joints, which have been specifically designed to seal against vacuum.

3.1.2. Piping

3.1.2.1. Minimum diameter pipe size shall be three inches in the collection system.

3.1.2.2. Cleanouts shall be provided at a maximum of every 200 feet on straight runs and at changes in direction.

3.1.2.3. Line shall be buried as deeply as dictated by frost depth or load condition.

3.1.2.4. Thrust blocks shall be located at each change in direction of the vacuum main.

3.1.2.5. Maximum length of any vacuum main shall be 6,000 feet,

Board of Health
Interpretive Rule 16-1
Series

however, longer lengths may be considered, provided adequate justification is presented, which will assure proper operation. The length of collection line must be justified based upon engineering calculations.

3.1.2.6. The lines shall be sized to provide a minimum of 2 fps velocity and shall accommodate the peak load from each residence or building served.

3.1.2.7. The manufacturer's recommendation for reform pockets and lifts shall be utilized.

3.1.2.8. Total available head loss from any input point should not exceed 18 feet of water. Five feet of water should be reserved for valve operation.

3.1.2.9. Installation of the collection system shall meet the following tightness test specification "the system shall be vacuumed to 24 inches of mercury vacuum pressure, allowed 15 minutes to stabilize, and thereafter shall not lose more than 1% vacuum pressure per hour over a minimum of a four-hour period." Testing should be done prior to the installation of valves.

3.2. House Connections

3.2.1. Valves shall be actuated by pneumatic or electric controllers. Those valve systems which are electrically controlled shall require a separate electrical power source at each valve site to control valve operation.

3.2.2. The valve shall be located outside the dwelling. The pipe between the dwelling and valve shall be located to provide 10-15 gallons storage, or a 30 gallon tank shall be located between the dwelling and the

Board of Health
Interpretive Rule 16-1
Series

valve. A permanent maintenance easement for the valve and its appurtenances shall be required.

3.2.3. Valve boxes shall have a solid bottom, and be counter weighted to prevent flotation. The cover and valve box material shall be of adequate strength to withstand the expected maximum dynamic and static loading conditions. Valve boxes shall be well vented to reduce condensation, and constructed of corrosion resistant material.

3.2.4. The vent system for the house must have a diameter of three inches or greater to prevent evacuation of traps during vacuum valve operation. The vent pipe shall be extended above the eaves of the house.

3.2.5. Those systems using a pneumatic controller shall have adequate protection of the sensor controllers, and any portion of the controller apparatus vented to atmosphere shall be protected from flooding, screened from insect entry, and provided with rain covers.

3.3. Sewage Collection Tanks

3.3.1. The sewage collection tanks shall be of either coated welded steel or fiber glass and shall be vacuum tight.

3.3.2. Each inlet to the tank shall have its own shut-off valve.

3.3.3. Liquid level sensors shall be installed to operate the discharge sewage pumps, the high level alarm and to interrupt the electrical power to the vacuum pumps.

3.3.4. The collection tank shall be sized to hold a maximum of 10 minutes design flow. Collection tanks shall be sized at 1.5 x operating volume or a minimum of 400 gallons.

3.4. Vacuum Pumps

Board of Health
Interpretive Rule 16-1
Series

3.4.1. Vacuum reserve tanks shall be installed in series between the sewage collection tank and the vacuum pumps.

3.4.2. Either liquid ring or sliding vane vacuum pumps may be used, as long as they are compatible with pumping moist air containing some sewer gases.

3.4.3. A check valve shall be installed between the vacuum reservoir tank and the vacuum pumps.

3.4.4. Dual vacuum pumps, each capable of handling the load, and emergency back-up power shall be provided.

3.4.5. The vacuum pump exhaust shall be vented outside the building. If there is a possibility of objectional odors, due to proximity of inhabited dwellings, the evacuation line from the vacuum reserve shall have carbon absorption.

3.5. Sewage Pumps

3.5.1. Dual pumps, each capable of handling 2.5 times the average daily flow, shall be provided.

3.5.2. Emergency back-up power shall be provided to operate the entire system.

3.5.3. The sewage pumps shall be capable of meeting the NPSH requirements as dictated by the vacuum conditions in the sewage collection tanks.

3.5.4. Shut-off valves shall be provided so that each pump may be isolated for repairs.

3.5.5. The discharge piping shall incorporate a check valve, gate valve arrangement such as utilized in a conventional pump station.

Board of Health
Interpretive Rule 16-1
Series

3.5.6. High level alarms and loss of vacuum alarms shall be located in an area which is manned 24 hours/day.

3.6. Design Requirements

3.6.1. Hydraulic calculations for the vacuum mains and force mains must be submitted with the application.

3.6.2. Plans and profiles of all mains must be submitted. Profiles must indicate depth to mains. All valves must be indicated on the plans.

3.6.3. The manufacturers recommendations shall be followed in design, when these standards are not applicable.

3.7. Maintenance and Operation

3.7.1. Factory trained maintenance personnel employed by the entity shall be available 24 hours/day.

3.7.2. Spare valves, controllers, valve pits, etc. must be kept in inventory.

3.7.3. Mixing of equipment (different makes and models) for a specific project will not be allowed.

3.8. Miscellaneous

3.8.1. Collection stations shall be supplied with ventilators and heater dehumidifiers.

3.8.2. Branch lines shall have individual cut off valves to allow isolation of the line for repair.

3.8.3. In new systems where water saving devices (such as vacuum toilets) are used, some lessening in the size of the treatment units shall be considered based upon review and approval of the director.

3.8.4. Spare controllers, valves, and sensors shall be retained on a

basis of 1 per each 10 units installed.

3.8.5. House vent stacks must be at least three inches in diameter. If necessary, a three to four inch stack shall be installed on the gravity sewer lateral adjacent to the house wall.

4.0. Pressure Sewage Collection System

4.1. General

4.1.1. Simplex units shall serve no more than two residences. Duplex units shall serve no more than four residences. Other multiple source applications shall be approved by the director.

4.1.2. Types of Pressure Systems

4.1.2.1. Grinder Pump Pressure System

4.1.2.2. Septic Tank Effluent Pumping Pressure System

4.1.3. Types of Pumps

4.1.3.1. Submersible, Centrifugal Grinder Pumps - Pumps shall be readily removable and replaceable without dewatering the wet well.

4.1.3.2. Semi-Positive Displacement Grinder Pumps

A. Pumps shall be readily removable and replaceable without dewatering the wet well.

B. Pressure relief valves are required unless other means of pressure relief are approved.

4.1.3.3. Non-Clog Submersible Centrifugal Effluent Pumps.

4.2. Design Requirements

4.2.1. Hydraulic Calculations - Calculations must be submitted with the application.

4.2.1.1. Peak flows shall be determined from the manufacturers recom-

Board of Health
Interpretive Rule 16-1
Series

mendations based upon the pumping equipment used.

4.2.1.2. Head losses due to valves and fittings must be included in the hydraulic calculations.

4.2.1.3. For purposes of calculation, a C=100 in the Hazen-Williams Formula must be used for all pipe, except a C=120 can be used for plastic pipe.

4.2.1.4. Design velocity shall be in the range of 2 to 5 ft/sec.

4.2.1.5. Design life of the pumps shall be computed on the basis of ten (10) years.

4.2.2. Plans - Plans and profiles of all pressure mains must be submitted. Profiles must indicate depth of pressure mains. All valves must be indicated on the plans.

4.2.3. Design - The design shall be in accordance with the standards herewith stated, except when not covered by this standard, then the manufacturer's recommendations shall be followed.

4.3. Pressure Mains

4.3.1. Type (Minimum Pressure Rating)

PVC SDR 21, Schedule 40, or PVC SDR 26 may be used.

4.3.2. Color - All pressure pipe shall be colored solid grey.

4.3.3. Size - The minimum size service line from the grinder pump to the collection main shall be 1½".

4.3.4. Valves and Cleanouts

4.3.4.1. Mains must be valved at junctions in order that segments of the system may be taken out of service for maintenance.

4.3.4.2. Cleanouts shall be provided at junctions so that lines may

Board of Health
Interpretive Rule 16-1
Series

be cleaned.

4.3.4.3. Cleanouts with valves shall be placed every 400 to 600 feet on straight runs.

4.3.4.4. Cleanouts and valves shall be located at changes in direction of the lines.

4.3.4.5. Air release valves shall be provided at high points in the line.

4.3.4.6. Ball or gate valves with cleanouts shall provided at the ends of lines.

4.3.4.7. A method of providing continuity of service shall be provided for main collector lines.

4.3.5. Thrust Blocks - Concrete thrust blocks shall be provided at changes in direction and at "T" junctions.

4.3.6. Flushing - One of the following methods shall be provided:

4.3.6.1. Flush tanks of one-thousand gallons capacity with pumps at the ends of lines.

4.3.6.2. Water hydrants (with backflow preventers) at the end of lines. The backflow preventer shall be of the reduced pressure type and shall be non-removable.

4.3.6.3. Water tank truck with pumps.

4.4. Grinder Pump Pressure System

4.4.1. Location

4.4.1.1. The pump station shall be located outside the residence or commercial building.

4.4.1.2. The control box for a single residence unit shall be located

on the outside of the building, preferably with the pump station.

4.4.1.3. For duplex grinder pump stations the control box shall be located with the pump station.

4.4.2. Electrical

4.4.2.1. Control panels shall be of the NEMA type 3 Enclosure.

4.4.2.2. The pump and float electrical controls shall have provisions for disconnection without entering the main control box.

4.4.3. Alarms

4.4.3.1. Where a single unit grinder pump station is utilized, a high water alarm light shall be placed outside the residence.

4.4.3.2. Where a dual grinder pump station is utilized, an alarm light and an audio alarm shall be placed at the control box by the pump station.

4.4.4. Emergency Holding

4.4.4.1. If a septic tank exists, such a tank maybe used for an emergency holding tank.

4.4.4.2. In areas of frequent power outages of a duration of more than four hours each, emergency holding tanks of 200 gallons capacity shall be installed.

4.4.5. Sequence of Connections - The sequence of valves, pump, and other appurtenances from the residence to the collection force main shall be as follows: four inch (4") sewer line, gate valve, pump, check valve, and connection line with 45 degree bend in the direction of flow.

4.4.6. Check and Gate Valves

4.4.6.1. Check or gate valves shall be either plastic or bronze.

Board of Health
Interpretive Rule 16-1
Series

4.4.6.2. Check valves may be either swing check or ball type. If swing type check valves are utilized, a 1 to 2 foot horizontal run of straight pipe shall be constructed on the downstream side of the check valve.

4.4.7. Level Controls - Level controls in the pump station shall be either mercury magnetic switches or mercury switches.

4.5. Septic Tank Effluent Pressure Systems

4.5.1. Location (Same as Grinder Pump Pressure Systems; See Subsection 4.4.1)

4.5.2. Controls

4.5.2.1. Control panels shall be NEMA type 3 enclosure.

4.5.2.2. The pump and float controls shall have provision for disconnection without entering the main control box.

4.5.3. Alarms (Same as Grinder Pump Pressure Systems; See Subsection 4.4.3)

4.5.4. Sequence of Connections - The sequence of valves, pump, and other appurtenances from the residence to the collection force main shall be as follows: four inch (4") sewer line, septic tank, pumping chamber with pump, check valve, gate valve and connection to main collection line with 45 degree bend in direction of flow.

4.5.5. Check and Gate Valves (Same as Subsection 4.4.6)

4.5.6. Level Controls (Same as Subsection 4.4.7)

4.5.7. Provisions for the treatment of septage shall be provided at the plant. A septic tank pumping vehicle shall be provided.

4.6. Maintenance and Operation

Board of Health
Interpretive Rule 16-1
Series

4.6.1. In the interest of obtaining proper maintenance and operation on a pressure sewer system, such a system must be either:

4.6.1.1. Under the jurisdiction of a public entity.

4.6.1.2. Under the jurisdiction of a private company regulated by the Public Service Commission.

4.6.2. Maintenance personnel employed by an entity operating a pressure system must attend a factory training course on maintenance and operation of the proposed units.

4.6.3. A truck provided with a hoist is recommended.

4.6.4. Permanent maintenance easements are required if the location of the pumping equipment and other appurtenances is on private property.

4.6.5. Spare parts, such as air relief valves, gate valves, relay switches, etc. must be kept in inventory.

4.6.6. Mixing of equipment (makes, models) for a specific project will not be allowed.

4.6.7. Spare pumps shall be provided in the initial design as follows:

<u>Installed Units</u>	<u>Spare Units</u>
1 to 10	1
11 to 20	2
21 to 30	3
31 to 40	4
41 to 50	5
51 to 75	6
76 to 100	7
101 to 150	8
151 to 200	9
201 to 300	10
301 to 400	11
401 to 500	12
501 - up	As approved by the director.

6.0 Manholes

6.1. Location - Manholes shall be provided at the end of each sewer line; at all changes in slope, size, or alignment; at all intersections; and at distances not greater than 400 feet for sewers 15 inches in diameter or less, and 500 feet for sewers 18 inches to 30 inches in diameter. Greater spacing may be permitted in larger sewers and in sewers carrying settled effluent. Cleanouts may be constructed at the upper end of short 6" laterals. Cleanouts may be substituted for manholes in some special situations, but approval by the director is required prior to submission.

6.2. Materials - Manholes shall be pre-cast concrete, poured-in-place concrete or concrete manhole block.

6.3. Drop Type - An outside drop pipe shall be provided for a sewer entering a manhole at an elevation of 24 inches or more above the manhole invert. (The entire drop connection shall be encased in concrete). If an inside drop is necessary, the pipe shall be fastened to the manhole and access provided for cleaning. Where the difference in elevation between the incoming sewer and manhole invert is less than 24 inches, the invert should be filled.

6.4. Diameter - The minimum base diameter of manholes shall be 48 inches; larger diameters are preferable for large diameter sewers. (Minimum opening 24")

6.5. Steps - Non-corrosive steps embedded in the walls, offset and spaced 12 to 18 inches apart vertically shall be provided.

6.6. Flow Channel - The inside base of the manhole shall be filled with concrete to form a bench sloping toward the flow channel. Both the

flow channel and the bench shall be trowelled to a smooth surface.

6.7. Watertightness - Solid manhole covers are to be used wherever the manhole covers may be flooded by street runoff or high water. Manholes of segmented block shall be water proofed on the exterior with plaster coatings, supplemented by a bituminous waterproof coating concrete manholes shall be waterproofed on the exterior where groundwater conditions are unfavorable. Pipe connections to manholes and joints on manholes shall be watertight.

7.0. Pumping Station

7.1. General

7.1.1. Flooding - Pumping stations including electrical equipment shall be located at an elevation not subject to the 100 year flood or shall otherwise be adequately protected against the 100 year flood.

7.1.2. Location - A suitable structure, preferably located off the right-of-way of streets and alleys shall be provided. The station shall be readily accessible. If possible, the station should be as far as possible from the nearest dwelling. Fencing shall be required to prevent entry of unauthorized persons.

7.1.3. Overflows - No overflows or bypasses from lift stations shall be permitted.

7.1.4. Pumping Rates and Number of Pumping Units - As a minimum dual pumps shall be provided at all lift stations, each capable of providing the maximum design flow. Pumping units shall be sized to provide the minimum cleaning velocity of 2.5 feet per second at the rated capacity, assuming a C=120 for plastic pipe and C=100 for all other pipe materials in the Hazen-

Williams Formula.

7.1.5. Type - Either the wet well or wet well/dry well type may be approved.

7.2. Design

7.2.1. Long Drive Shaft Pumps - A wet well installation in which the pump is mounted in the wet well and connected by a drive shaft to the motor above the wet well, will not be approved.

7.2.2. Separation - Wet well and dry well including their super-structure shall be completely separated.

7.2.3. Pump Removal - Provisions shall be made to facilitate removing pumps and motors.

7.2.4. Access - Suitable and safe means of access shall be provided to dry wells of pumping stations and shall be provided to wet wells containing either bar screens or mechanical equipment requiring inspection or maintenance.

7.2.5. Size - The effective capacity of the wet well should provide a detention time not exceeding 30 minutes for the design average flow.

7.2.6. Floor Slope - The wet well floor shall have a minimum slope of one to one towards the hopper bottom. The horizontal area of the hopper bottom shall be no greater than necessary for proper installation and function of the inlet. Bottoms shall have a smooth finish.

7.2.7. Protection Against Clogging - Pumps handling raw sewage may be preceded by readily accessible bar screens with clear openings not exceeding 2½ inches, unless pneumatic ejectors are used or special devices are installed to protect the pumps from clogging or damage. Where the size of the

Board of Health
Interpretive Rule 16-1
Series

installation warrants, a mechanically cleaned bar screen with grinder, or comminution device is recommended. Where screens are located, convenient facilities must be provided for handling screenings. For the larger or deeper sections, duplicate protection units of proper capacity are preferred.

7.2.8. Pump Openings - Pumps shall be capable of passing 2½ inch solids, or be of the grinder pump type when used in residential developments of 500 persons or less. Pumps for all other installations shall be capable of passing 3 inch solids or be of the grinder pump type. Pumps shall be non-clog type pumps or ejectors.

7.2.9. Priming - The pump shall be so placed that under normal operating conditions it will operate under a positive suction head, except as specified for suction lift pumps.

7.2.10. Electrical Equipment - Electrical systems and components (e.g. motors, lights, cables, conduits, switchboxes, control circuits, etc.) in enclosed or partially enclosed spaces where gas may be present (including raw wastewater wet wells) shall comply with the National Electrical Code requirements for Class I, Group D, Division I locations.

7.2.11. Intake - Each pump shall have an individual intake. Wet Well design should be such as to avoid turbulence near the intake.

7.2.12. Dry Well Dewatering - A separate pump shall be provided in the dry wells to remove leakage or drainage with the discharge above the overflow level of the wet well. A connection to pump suction is also recommended as an auxiliary feature. Water ejectors connected to a drinking water supply will not be approved. All floor and walkway surfaces should

have an adequate slope to a point of drainage.

7.2.13. Controls - Control float cables shall be so located as not to be affected by the flows entering the wet well or by the suction of pumps. Float tubes in dry wells shall extend high enough to prevent overflow. Provision should be made to automatically alternate the pump in use. Pump stations with motors or controls below grade shall be equipped with a secure external disconnect switch.

7.2.14. Valves and Piping - Pumps shall be equipped with a full closing valve on the suction piping except on submersible and vacuum-primed pumps. A check valve followed by a gate valve shall be installed on the discharge piping. Valves shall not be located in a wet well.

7.2.15. Ventilation - Mechanical ventilation must be provided if routine maintenance will require personnel to enter the station.

7.2.15.1. Wet Wells - Ventilation may be either continuous or intermittent. Ventilation, if continuous, shall provide at least 12 complete air changes per hour; if intermittent, at least 30 complete air changes per hour.

7.2.15.2. Dry Wells - Ventilation may be either continuous or intermittent. Ventilation, if continuous, shall provide at least six complete air changes per hour; if intermittent, at least 30 complete air changes per hour.

7.2.16. Flow Measurement - The capability for emplacing suitable devices for measuring sewage flow shall be provided at all pumping stations. Such devices will be required to be in place at critically located pumping stations.

Board of Health
Interpretive Rule 16-1
Series

7.2.17. Water Supply - There shall be no physical connection between any potable water supply and a sewage pumping station.

7.2.18. Alarm Systems - All pump station installations shall be provided with a high water alarm light at the lift station.

7.2.19. Reliability - Emergency power may be required under specific circumstances, such as, above water intakes, recreational waters, or other situations as determined by the director.

7.2.20. Portable Equipment - In some instances portable equipment may furnish service to more than one pumping station; however, where such equipment is utilized, it shall have the capability to operate between the wet well and the discharge side of the station. The station shall be provided with permanent fixtures, which will facilitate rapid and easy connection of lines.

7.2.21. Emergency Power Generation - All emergency power generation equipment, if required, shall be provided with instructions indicating the essentiality of routinely and regularly starting and running such units at full load.

7.3. Suction Lift Pumps

7.3.1. Suction lift pumps shall be of the self-priming or vacuum priming type.

7.3.1.1. Self-priming Pumps - Shall be capable of rapid priming and repriming at the "lead pump on" elevation. Such self-priming and repriming shall be accomplished automatically under design operating conditions. Suction piping should not exceed the size of the pump suction and shall not exceed 25 feet in total length. Priming lift at the "lead pump on" eleva-

Board of Health
Interpretive Rule 16-1
Series

tion shall include a safety factor of at least 4 feet from the maximum allowable priming lift for the specific equipment at design operating conditions. The combined total of dynamic suction lift at the "pump off" elevation and required net positive suction head at design operating conditions shall not exceed 22 feet.

7.3.1.2. Vacuum-priming Pump Stations - Shall be equipped with dual vacuum pumps capable of automatically and completely removing air from the suction lift pump. The vacuum pumps shall be adequately protected from damage due to sewage. The combined total of dynamic suction lift at the "pump off" elevation and required net positive suction head at design operating conditions shall not exceed 22 feet.

7.3.2. The capacity of a suction lift pump station shall be limited by the net positive suction head and specific speed requirements as stated on the manufacturer's pump curve under the most severe operating conditions.

7.3.3. Suction lift pumps shall not be located within the wet well.

7.3.4. Access to the wet well shall not be through the dry well, and the dry well shall have a gas-tight seal when mounted directly above the wet well.

7.4. Submersible Pumps

7.4.1. Pump Removal - Pumps shall be readily removable and replaceable without dewatering the wet well or disconnecting any piping in the wet well.

7.4.2. Hoist Provision - A submersible pumping facility may be required to have a hoist for removing the pump from the wet well.

7.4.3. Electrical Control Location - Electrical controls must be

located outside the wet well in a suitable housing for protection against weather and vandalism.

7.5. Pneumatic Ejectors

7.5.1. Venting - Ejector pots shall be vented to the atmosphere.

7.5.2. Duplicate Compressors - Duplicate compressors shall be provided and consideration shall be given to providing an air storage tank.

7.6. Force Mains

7.6.1. Size - Minimum size of force mains to serve facilities having a population equivalent of 500 people or less shall be three (3) inches for solids passing pumps. Minimum size of force mains serving population equivalent of over 500 population, shall be four (4) inches for solids passing pumps. Smaller size force mains may be utilized in conjunction with grinder pumps.

7.6.2. Air Relief Valve - Air relief valves shall be placed at high points in the force mains.

7.6.3. Termination - The force mains should enter the receiving manhole with its center-line horizontal and with an invert elevation which will insure a smooth laminar flow transition to the gravity flow section, but in no case shall the force main enter the gravity sewer system at a point more than one foot above the flow line of the receiving manhole. The design shall especially prevent turbulence at this point. (Immediately upstream, the force main design shall include a positive trap to keep the force main full of liquid at all times.) For discharge into deep manholes, a raised section may be provided, and for shallow manholes, a depressed section may be provided. Attention should be given to the use of inert mat-

Board of Health
Interpretive Rule 16-1
Series

erial or protective coatings for receiving manholes and sewers to prevent deterioration as a result of hydrogen sulfide.

7.6.4. Materials of Construction - Force mains shall be constructed of plastic, cast iron, asbestos cement or cement lined steel pipe bearing the nsf seal and of the pressure class required by the total dynamic head.

7.6.5. Anchoring - Force mains shall be sufficiently anchored within the pump station and throughout the line length. The number of bends shall be as few as possible. Thrust blocks, restrained joints, or tie rods shall be provided where restraint is needed.

Board of Health
Interpretive Rule 16-1
Series

SECTION 4

Part III

SEWAGE TREATMENT WORKS

Part III

SEWAGE TREATMENT WORKS

INDEX

Subsection

Page

1.0	General.	
2.0	Screening Devices and Comminutors.	
3.0	Grit Removal	
4.0	Pre-Aeration	
5.0	Flow Equilization.	
6.0	Settling	
7.0	Activated Sludge	
8.0	Trickling Filters.	
9.0	Rotating Biological Contactors	
10.0	Other Biological & Mechanical Systems.	
11.0	Sewage Stabilization Ponds, Anaerobic Lagoons, and Aeration Lagoons	
12.0	Disinfection	
13.0	Supplementary Treatment.	
14.0	Sludge Handling and Disposal	
15.0	Other Sewage Sludge Disposal Methods	
16.0	Land Application of Sewage Effluent.	
	APPENDIX A--Minimum Design Loading for Sewage Treatment Facilities.	

Board of Health
Interpretive Rule 16-1
Series

1.0. GENERAL

1.1. Sewage treatment plants shall be designed to provide for an estimated population 20 years hence. All plants shall be designed so they can readily be increased in capacity except where circumstances preclude the probability of expansion.

1.2. Plant Location - A sewage treatment plant site shall be as far as practicable from any present built-up or any area which will probably be built up within a reasonable future period. A buffer zone as indicated in Table 1 shall be provided from any surrounding occupied structure to the plant site. The direction of prevailing winds should be considered when selecting the plant site. The plants operational units shall be located at an elevation which is not subject to the 100 year flood or shall otherwise be adequately protected against 100 year flood damage. The plant shall remain fully operational during a 25-year-flood. The plant shall be readily accessible in all seasons. The site shall be of sufficient size to accommodate expansion or addition of facilities to increase the degree of treatment.

Table 1

BUFFER ZONE REQUIREMENTS FOR SEWAGE TREATMENT UNITS

<u>Package Sewage Treatment Plants</u>	<u>Buffer Zone Requirements</u>
40,000 gpd or less and polishing ponds, package sand filters and alternating surface sand filters, TKN removal equipment, aerated lagoons	100 feet
40,001 gpd -- 100,000 gpd	200 feet
greater than 100,000 gpd	300 feet
Lagoons, Trickling Filters, Land Treatment Systems.	
All units	300 feet

1.2.1. The buffer zone requirements in Table 1 may be waived by the director upon filing of a release of the requirements by the owner(s) of the occupied structure within the buffer zone.

1.3. Quality of Effluent

1.3.1. Surface Water Discharge - The required degree of wastewater treatment shall be based on the stream standards and water quality criteria established by the Water Resources Board and effluent limitations established by the Division of Water Resources. More stringent requirements may be established by the director if a public water supply intake, a recrea-

Board of Health
Interpretive Rule 16-1
Series

tional water use area or aquaculture is located downstream from the discharge point.

1.3.2. Land Discharge - See Subsection 16.

1.3.3. New Processes, Methods and Equipment - The policy of the director is to encourage the development of new processes, methods and equipment for sewage treatment. The following may be required:

1.3.3.1. Monitoring observations, including test results and engineering evaluations, demonstrating the efficiency of such processes.

1.3.3.2. Detailed description of the test methods.

1.3.3.3. Testing, including appropriately-composited samples, under various ranges of strength and flow rates (including daily variations) and waste temperatures over a sufficient length of time to demonstrate performance under climatic and other conditions which may be encountered in the area of the proposed installations.

1.3.3.4. Other appropriate information. The director may require that appropriate testing be conducted and evaluations made under the supervision of a competent process engineer other than those employed by the manufacturer or developer.

1.3.3.5. A performance bond may be required.

1.4. Design

1.4.1. Industrial Wastes - When treating industrial and institutional wastes in a sewage treatment works, consideration shall be given to the character of the wastes in the design of the plant. In such cases, treatability studies on the composite wastewater may be required prior to the plant design.

Board of Health
Interpretive Rule 16-1
Series

1.4.2. Hydraulic Loading - The design of treatment plant units shall be based on the average rate of sewage flow per 24 hours except where significant deviations from the normal daily flow pattern are noted.

1.4.3. Existing Sewage Systems - Where there are existing sewers, the volume and strength of sewage flow shall be determined. These data shall be obtained from actual flow measurements, preferably for both wet and dry weather periods. Laboratory analysis shall be made on composite samples taken over 24-hour periods. Plans and specifications for sewage works to serve existing sewage systems will be designed on the basis of characteristics and strength of sewage as shown by results of composite samples examined and gaugings of the present flow plus allowance for estimated increase in population. In addition, non-excessive infiltration/inflow will be included.

1.4.4. New Sewage Systems - Where new sewers are to be constructed, plans for sewage treatment works shall be designed on the basis of 70 gallons per capita per day.

1.4.5. Organic Loading - The design organic loading shall be computed in the same manner used in determining design flow. Generally, organic loading shall be computed at 0.17 pounds of five-day BOD per person per day.

1.4.6. Conduits - All piping and channels shall be designed to carry the maximum expected flows. The incoming sewer shall be designed for free discharge. Bottom corners of the channels must be filleted. Pockets and corners where solids can accumulate shall be eliminated. Suitable gates shall be placed in channels to seal off unused sections which might accumulate solids. The use of shear gates or stop planks is permitted where

Board of Health
Interpretive Rule 16-1
Series

they can be used in place of gate valves or sluice gates.

1.4.7. Arrangement of Units - Component parts of the plant shall be arranged for greatest operating convenience, flexibility, economy, and so as to facilitate installation of future units. Multiple treatment units shall be provided for plants greater than 100,000 gallons in size. Appurtenances shall be provided in such a manner that any unit may be temporarily taken out of service. The remainder of the plant must be operational with the unit or units out of service. In the case of oxidation ditches, the above requirements are satisfied if multiple rotors are provided.

1.5. Miscellaneous

1.5.1. Provisions for Taking Units Out of Service - Properly located and arranged diversion piping and structures shall be provided so that either dual or multiple units of the plant can be removed from service independently for inspection, maintenance, and repairs.

1.5.2. Dewatering - Means shall be provided to dewater each unit. Due consideration shall be given to the possible need for hydrostatic pressure relief devices.

1.5.3. Construction Materials - Due consideration shall be given to the selection of materials which are to be used in sewage treatment works because of the possible presence of hydrogen sulfide and other corrosive gases, greases, oils, and similar constituents frequently present in sewage. This is particularly important in the selection of metals and paints. Dissimilar metals should be avoided to minimize galvanic action.

1.5.4. Covering Units - Properly vented covers may be used.

1.5.5. Painting - The use of paints containing lead or mercury should

Board of Health
Interpretive Rule 16-1
Series

be avoided. In order to facilitate identification of piping it is suggested that the different lines be color-coded. The following color scheme is recommended for purposes of standardization.

Sludge line	Brown
Gas line	Orange
Potable water line	Blue
Chlorine line	Yellow
Sewage line	Gray
Compressed air line	Green
Water lines for heating digesters or buildings	Blue with 6 inch red bands spaced 30 inches apart

The contents shall be stenciled on the piping in a contrasting color. The above color scheme is only required for plants of over 100,000 gallons in size.

1.5.6. Operating Equipment - The specifications shall include a complete outfit of tools and accessories for the plant operator's use, such as squeegees, wrenches, valve keys, rakes, shovels, etc. A portable pump is desirable. Readily accessible storage space and work bench facilities shall be provided and consideration given to provision of a garage area which would also provide space for large equipment, maintenance and repair.

Board of Health
Interpretive Rule 16-1
Series

1.5.7. Grading and Landscaping - Concrete or gravel walkways should be provided for access to all units. Where possible, steep slopes shall be avoided to prevent erosion. Surface water shall not be permitted to drain into any unit. Particular care shall be taken to protect trickling filter beds, sludge beds, and intermittent sand filters from surface water. Provision should be made for landscaping, particularly when a plant must be located near residential areas.

1.6. Plant Outfalls

1.6.1. Outlet - The outfall sewer, where practicable, shall be extended to the low water level of the receiving body of water in such a manner to insure satisfactory dispersion of the effluent thereto, and insofar as practicable, it shall have its outlet submerged. Headwalls may be used where adequate dispersion is obtained without carrying the outfall into the stream.

1.6.2. Design and Construction - The outfall sewer shall be so constructed and protected against the effects of flood water, ice, or other hazards as to reasonably insure its structural stability and freedom from stoppage.

1.7. Essential Facilities

1.7.1. Emergency Power

1.7.1.1. General - All plants greater than 100,000 gallons in size shall be provided with an alternate source of electric power to allow continuity of operation during power failures, except as noted below.

A. Methods of providing alternate sources include:

1. The connection of at least 2 (two) independent public utility

Board of Health
Interpretive Rule 16-1
Series

sources, such as substations. A power line from each substation is recommended, and will be required unless documentation is received and approved by the reviewing agency verifying that a duplicate line is not necessary to minimize water quality violations;

2. Portable or in-place internal combustion engine equipment which will generate electrical or mechanical energy; and

3. Portable pumping equipment when only emergency pumping is required.

B. Power for Aeration - Standby generating capacity normally is not required for aeration equipment used in the activated sludge process. Where power outages of four (4) hours or more are common, auxiliary power for minimum aeration of the activated sludge will be required. Full power generating capacity may be required by the reviewing authority on certain critical stream segments.

C. Power for Disinfection - Continuous disinfection, where required, shall be provided during all power outages.

1.7.2. Electrical Equipment - All electrical equipment such as motors and local controls, and electrical conduits shall either be located at an elevation above the 100 year flood level or be of waterproof design. All outdoor equipment shall be adequately protected from the weather. Motors located indoors, and near liquid handling piping and equipment, shall be of splashproof design. All electrical wires in underground conduits or in conduits that can be flooded shall have water resistant insulation as identified in the National Electrical Code.

1.7.3. Water Supply

Board of Health
Interpretive Rule 16-1
Series

1.7.3.1. General - An adequate supply of drinking water shall be provided for use in the laboratory and general cleanliness around the plant. No piping or other connections shall exist in any part of the treatment works which, under any condition, might cause the contamination of a drinking water supply. The chemical quality should be checked for suitability for the intended use, in heat exchangers, chlorinators, etc.

1.7.3.2. Direct Connections - The drinking water supply line to each treatment plant shall be equipped, as a minimum, with an approved reduced-pressure type backflow preventer. These devices must be installed in a location to prevent flooding, corrosion and allow for adequate, quick service and periodic inspections. Installation in below grade meter type vaults will not be acceptable. All water supply take-off points must follow the devices and no extension of this line to serve the public shall be allowed. Drinking water from a municipal or separate supply may be used directly at points above grade for the following hot and cold supplies:

- A. Lavatory sinks
- B. Water Closets
- C. Laboratory sinks which are equipped with approved vacuum breakers.
- D. Showers
- E. Drinking fountains
- F. Approved outside hydrants
- G. Hose bibbs which are equipped with nonremovable vacuum breakers.
- H. Chlorinators provided with suitable vacuum breakers or other approved backflow preventers appropriately installed. Hot water for any of the above units shall not be taken directly from a boiler used for supplying

Board of Health
Interpretive Rule 16-1
Series

hot water to a sludge heat exchanger or digester heating coils.

1.7.3.3. Indirect Connection - Where a potable water supply is to be used for any purpose in a plant other than those listed in Subsection 1.7.3.2, a break tank, pressure pump, and pressure tank shall be provided. Water shall be discharged to the break tank through an air-gap at least six (6) inches above the maximum flood line or the spill line of the tank, whichever is higher. A sign shall be permanently posted at every hose bibb, faucet, or stop cock located on the water system beyond the break tank to indicate that the water is not safe for drinking.

1.7.3.4. Separate Drinking Water Supply - Where it is not possible to provide drinking water from a public water supply, a separate well may be provided. Location, construction and testing of the well shall comply with requirements of the state department of health. Requirements governing the use of the supply are those contained in Subsection 1.7.3.2 and Subsection 1.7.3.3. Approval of the supply must be obtained from the director prior to construction.

1.7.3.5. Separate Non-Drinking Water Supply - Where a separate non-drinking water supply is to be provided, stop cocks, hose bibbs, and other water outlets shall be posted with a permanent sign indicating the water is not safe for drinking.

1.7.4. Sanitary Facilities - All sewage treatment plants with laboratory facilities shall be provided with a shower, toilet, and lavatory. Locker facilities shall also be provided.

1.7.5. Sewage Flow Measurement - Facilities for measuring the volume of sewage flows shall be provided at all treatment works greater than

Board of Health
Interpretive Rule 16-1
Series

100,000 gallons in size. All plants having a capacity of greater than 100,000 gallons per day shall be equipped with indicating, recording, and totalizing equipment for effluent flow measurement.

1.7.6. Floor Slope - Floor surface shall be sloped adequately to a point of drainage.

1.7.7. Stairways - Stairways shall be installed with a slope of 30 to 35 degrees from the horizontal to facilitate carrying samples, tools, etc. All risers in a stairway should be of equal height. All stairways must be provided with handrails.

1.8. Safety - and visitors from hazards. Following are the minimum requirements for all plants:

1.8.1. Enclosure of the plant site with a minimum six feet high fence with a locked entrance gate designed to discourage the entrance of unauthorized persons and animals.

1.8.2. Installation of handrails, grating, and guardrails where necessary, such as open basins, screen channels, mechanical equipment and other hazardous places. For all extended aeration plants of 40,000 gallons per day or less grating will be required.

1.8.3. Provision of first-aid equipment.

1.8.4. Posting of "No Smoking" signs in hazardous locations.

1.8.5. Provision of protective clothing and equipment such as gas masks, gloves, etc.

1.8.6. Provision of portable blower and sufficient hose.

1.8.7. Explosion proof electrical equipment, nonsmoking tools shall be provided in work areas where hazardous conditions may exist, such as

Board of Health
Interpretive Rule 16-1
Series

digester vaults and other locations where potentially explosive atmospheres of flammable gas or vapor accumulate.

1.8.8. All electrical wiring shall be properly grounded and insulated. No part of the plant piping may be used for grounding.

1.8.9. Portable lighting equipment shall be provided.

1.8.10. All manhole steps shall have slip-proof rungs and the steps shall be of the railroad type which will help prevent foot slippage off the ends of the rungs.

1.8.11. Separate storage located remotely from the plant shall be provided for flammable and hazardous material.

1.8.12. Heating devices with open flames shall be located in separate rooms with outside entrances, and at grade or above.

1.8.13. Particular safety precautions for gas-collection piping shall be installed.

1.8.14. Adequate ventilation must be provided.

1.8.15. Chlorinator rooms and chlorine storage areas shall be equipped with heat, light, and a ventilation fan must be capable of being turned on from outside the room. The room shall be at grade or above. A viewing window from the plant interior shall be provided.

1.8.16. The treatment works should comply with the provisions of the Occupational Safety and Health Act (OSHA).

1.9. Laboratory Space - All treatment works shall have facilities, either contractual or on-site, for making the necessary analytical determinations and operating control tests. Whenever an on-site laboratory is utilized, isolation should be such as to render the laboratory reasonably

Board of Health
Interpretive Rule 16-1
Series

free from the adverse effects of noise, heat, vibration, and dust. Minimum laboratory space for facilities not performing BOD and suspended solids testing on-site shall be 100 square feet floor space with 35 square feet bench area. Facilities providing on-site BOD, suspended solids, and fecal coliform analysis shall provide a minimum of 400 square feet floor space and 150 square feet of bench space. If more than two persons will be working in the laboratory at any given time, 100 square feet of additional space should be provided for each additional person. Advanced wastewater treatment plants shall provide a minimum of 100 additional square feet of floor space with proportionate increase in bench space. Lists of laboratory equipment shall be compiled from the latest edition of Standard Methods for the Examination of Water & Wastewater, by APHA - AWWA - WPCF.

1.10. Laboratory Equipment - All treatment works shall be provided with laboratory equipment determined by the director based upon type and complexity of the treatment process. However all extended aeration treatment plants of 100,000 gallons per day or less shall be provided with the following:

1.10.1. Test kit for pH and for chlorine residual. This test kit shall be of the comparator type as manufactured by Hach, Taylor, Hellige or Wyandotte.

1.10.2. Two (2) 1-liter graduated beakers.

1.10.3. Secchi disk.

1.10.4. Squeegee with proper length of handle, five (5) quart bucket and rubber gloves.

2.0. Screening Devices and Comminutors

2.1. Bar Racks and Screens

2.1.1. Protection for pumps and other equipment shall be provided by either coarse bar racks or bar screens. Protection for comminutors should be provided by coarse bar racks.

2.1.2. Location

2.1.2.1. Indoors - Screening devices, installed in a building where other equipment or offices are located, should be accessible only through a separate outside entrance.

2.1.2.2. Outdoors - Screening devices installed outside shall be protected from freezing.

2.1.2.3. Access - Screening areas shall be provided with stairway access, lighting and ventilation, and a convenient means for removing the screenings.

2.1.3. Design and Installation

2.1.3.1. Bar Spacing - Clear openings between bars should be no less than one inch for manually cleaned screens. Clear openings for mechanically cleaned screens may be as small as 5/8 of an inch. Maximum clear openings should be 1 3/4 inches.

2.1.3.2. Slope - Manually cleaned screens, except those for emergency use, should be placed on a slope of 30 to 45 degrees from the horizontal.

2.1.3.3. Velocities - At normal operating flow conditions, approach velocities should be no less than 1.25 feet per second, to prevent settling; and no greater than 3.0 fps through the bar screen to prevent forcing material through the openings.

2.1.3.4. Channels - For plants of greater than 100,000 gallons per

Board of Health
Interpretive Rule 16-1
Series

day, dual channels shall be provided and equipped with the necessary gates to isolate flow from any screening unit. Provisions shall also be made to facilitate dewatering each unit. The channel preceding and following the screen shall be shaped to eliminate stranding and settling of solids. Channels shall be 3 to 6 inches below the invert of the incoming sewer.

2.1.3.5. Mechanical Devices - A positive means of locking out each mechanical device shall be provided.

2.1.4. Control Systems

2.1.4.1. Timing Devices - All mechanical units without timing devices must run continuously. All mechanical units which are operated by timing devices shall be provided with auxiliary control which will set the cleaning mechanism in operation at predetermined high water elevations.

2.1.4.2. Electrical Fixtures and Controls - Electrical fixtures and controls in screening areas where hazardous gases may accumulate shall meet the requirements of the National Electrical Code for Class 1, Group D, Division 1 locations.

2.1.4.3. Manual Override - Automatic controls shall be supplemented by a manual override.

2.1.5. Auxiliary Screens - Where mechanically operated screening or comminuting devices are used, auxiliary manually cleaned screens shall be provided. Design shall include provisions for automatic diversion of the entire sewage flow through the auxiliary screens should the regular units fail.

2.1.6. Fine Screens - The use of fine screens in lieu of sedimentation is not permitted. In special cases where it can be demonstrated that

Board of Health
Interpretive Rule 16-1
Series

the features peculiar to fine screens may be advantageous, such proposed installation may be approved by the department of health on a case-by-case basis.

2.1.7. Disposal of Screenings - Facilities must be provided for removal, handling, storage, and disposal of screenings in a sanitary manner. Manually cleaned screening facilities shall include an accessible platform from which the operator may rake screenings easily and safely. Suitable drainage facilities shall be provided both for the platform and for storage areas. Grinding of screenings and return to the sewage flow is prohibited. Open area disposal is prohibited. Screenings may be buried in a manner approved by the director or placed in a landfill when permitted.

2.2. Comminutors

2.2.1. Location - Comminutors may be required at sewage treatment plants 40,000 gallons or greater in size. Comminutors should be located downstream of any grit removal equipment.

2.2.2. Size - Comminutors shall be designed to handle peak flow.

2.2.3. Installation - A bar screen bypass channel shall be provided. The use of the bypass channel should be automatic at depths of flow exceeding the design capacity of the comminutor.

2.2.4. Servicing - Provision shall be made to facilitate servicing units in place and removing units from their location for servicing.

2.2.5. Macerators and Grinder Pumps - Macerators and grinder pumps or similar devices may be used in lieu of comminutors where approved by the director.

3.0. Grit Removal

Board of Health
Interpretive Rule 16-1
Series

3.1. General - Grit removal facilities shall be provided for all sewage treatment plants serving combined sewer systems. Provision shall be made for further installation of grit removal facilities for all plants of greater than 100,000 gallons in size serving new sanitary sewer systems. Grit removal facilities may be required for new plants serving existing sewer systems. All sewage treatment plants having anaerobic digesters will require grit removal.

3.2. Location - Grit removal facilities, except in unusual circumstances shall be located ahead of pumps and comminuting devices, and coarse bar racks should be placed ahead of mechanically cleaned grit removal facilities.

3.3. Type and Number of Units - Grit removal facilities for plants treating wastes from combined sewers shall have at least 2 manually cleaned units or one mechanically cleaned unit and one manually cleaned unit. Facilities other than channel-types are desirable for plants 100,000 gallons or greater in size, if provided with flexible controls for agitation or air supply devices and with grit removal equipment.

3.4. Velocity-Controlled Grit Removal

3.4.1. Inlet - Inlet turbulence shall be minimized.

3.4.2. Velocity and Detention - Channel-type chambers shall be designed to provide a velocity of 1 foot per second. The detention time shall be based on the size of particles (0.21 mm) to be removed. The design should take into consideration undesirable turbulence and velocities at inlets and outlets.

3.4.3. Grit Washing - The need for grit washing should be determined

Board of Health
Interpretive Rule 16-1
Series

by the method of final grit disposal.

3.4.4. Drains - Provisions shall be made for dewatering each unit.

3.4.5. Water - An adequate supply of water under pressure shall be provided for clean up.

3.4.6. Grit Removal - Grit removal facilities located in deep pits shall be provided with mechanical equipment for pumping or hoisting grit to ground level. Such pits shall have a stairway, elevator or manlift, ventilation, and lighting, and be provided with means of drainage.

3.5. Aerated Grit Removal

3.5.1. Air Diffusers - Air diffusers shall be located on one side of the tank, 2 to 3 feet above the tank bottom.

3.5.2. Air Supply Rate - A detention time of 3 minutes at the maximum rate of flow shall be provided.

3.5.3. Inlet and Outlet - Design of the aerated grit chamber must be such as to prevent short circuiting at the inlet and outlet. The inlet to the chamber shall introduce the wastewater directly into the circulation pattern caused by the air diffusion. The outlet shall be at a right angle to the inlet and a baffle shall be installed near the outlet.

3.5.4. Grit Removal - The aerated grit chambers shall be provided with mechanical grit removal equipment.

3.6. Grit Handling - Impervious surfaces with drains should be provided for grit handling areas. If grit is to be transported, the conveying equipment should be designed to avoid loss of material and to provide protection from freezing.

3.7. Grit Disposal - Grit may be buried in a manner approved by the

Board of Health
Interpretive Rule 16-1
Series

director or placed in a landfill when permitted.

4.0. Pre-aeration

4.1. General - Pre-aeration of sewage to reduce septicity may be required in special cases.

5.0. Flow Equalization

5.1. General - Flow equalization shall be provided where large daily variations in organic or hydraulic loadings are expected.

5.2. Location - Equalization basins shall be located downstream of pretreatment facilities such as bar screens, comminutors, and grit chambers.

5.3. Type - Flow equalization can be provided by using separate basins or on-line treatment units, such as aeration tanks. Equalization basins may be designed as either in-line or side-line units.

5.4. Design

5.4.1. Mixing - Mixing requirements for normal raw domestic wastewaters shall range from 0.02 to 0.04 hp/1000 gallons of maximum storage volume.

5.4.2. Aeration - A minimum of 1.0 mg/l of dissolved oxygen shall be maintained in the mixing basin at all times. Air supply rates should be a minimum of 1.25 cfm/1000 gallons of storage capacity.

5.4.3. Storage - Sufficient storage shall be provided to allow the sections of the plant which follow the storage to operate at or at less than their rated design capacity.

5.4.4. Detention/Equalization - Basins designed for a combination of storage of wet weather flows and equalization shall be compartmentalized to allow utilization of a portion of the basins for dry weather flow equalization.

Board of Health
Interpretive Rule 16-1
Series

5.4.5. Flow Discharge Control - Multiple pumping units capable of delivering the desired flow rate from the equalization basin with the largest pumping unit out of service shall be provided.

5.4.6. Aeration Support - When floating surface aerators are provided, provisions shall be made to protect the units when the tank is dewatered.

5.4.7. Basin Cleaning - Facilities shall be provided to flush solids and grease accumulations from the basin walls.

5.4.8. Scum Control - For plants greater than 100,000 gallons in size a high-water-level takeoff shall be provided for withdrawing floating material where subsurface diffusers are used.

5.4.9. Controls - The following controls shall be provided for plants greater than 100,000 gallons per day. Inlets and outlets for all basin compartments shall be suitably equipped with accessible external valves, stop plates, weirs, or other devices to permit flow control, level control, and the removal of an individual unit from service. Facilities shall also be provided to measure and indicate liquid levels and flow rates.

6.0. Settling

6.1. Inlets - Inlets should be designed to dissipate the inlet velocity, to distribute the flow equally, and to prevent short-circuiting. Channels should be designed to maintain a velocity of at least 1 foot per second at one-half design flow. Corner pockets and dead ends should be eliminated and corner fillets or channeling used where necessary. Provisions shall be made for elimination or removal of floating materials in inlet structures having submerged ports.

Board of Health
Interpretive Rule 16-1
Series

6.2. Dimensions - The minimum length of flow from inlet to outlet should be 10 feet unless special provisions are made to prevent short-circuiting. The liquid depth of mechanically cleaned settling tanks shall be as shallow as practicable but not less than seven feet. Sidewater depth for final clarifiers for activated sludge should not be less than 12 feet for plants greater than 100,000 gallons in size.

6.3. Scum Removal - Effective scum collection and removal facilities, including baffling, shall be provided ahead of the outlet weirs on all settling tanks. Provisions may be made for discharge of scum with the sludge; other provisions may be necessary to dispose of floating materials which may adversely affect sludge handling and disposal.

6.4. Weirs - Overflow weirs shall be adjustable. Weir loadings should not exceed 10,000 gallons per day per linear foot for plants designed for average flows of 1.0 mgd or less. Special consideration will be given to weir loadings for plants designed for flows in excess of 1.0 mgd, but such loadings should not exceed 15,000 gallons per day per linear foot. If pumping is required, pump capacity should be related to tank design to avoid excessive weir loading.

6.5. Submerged Surfaces - The tops of beams and similar construction features which are submerged shall have a minimum slope of 1.4 vertical to 1 horizontal. The underside of such features should have a slope of one to one to prevent the accumulation of scum or solids.

6.6. Multiple Units - Multiple units capable of independent operation shall be provided at all plants having a capacity greater than 100,000 gallons per day.

6.7. Protective and Servicing Facilities - In plants greater than 100,000 gallons in size all settling tanks shall have provision for easy access for maintenance, and protection of operators. Such features include stairways, walkways, handrails, etc. If side walls are extended some distance above the liquid level to provide flood protection for other purposes, convenient walkways shall be provided to facilitate housekeeping and maintenance of weirs.

6.8. Surface Settling Rates

6.8.1. Primary Settling Tanks - Surface settling rates for primary tanks shall not exceed 1000 GPD per square foot at design flow or 1500 GPD per square foot for peak hourly flows, whichever is larger, for plants having a design flow of 1.0 mgd or less. Higher surface settling rates may be permitted for larger plants.

6.8.2. Intermediate Settling Tanks - Surface settling rates for intermediate settling tanks, where used following fixed film reactors, should not exceed 1,500 GPD per square foot based on their design flow.

6.8.3. Final Settling Tanks - Surface settling rates for final settling tanks, based on maximum flow rates, shall be as follows:

6.8.3.1. Fixed Film Biological Reactors - Surface settling rates for settling tanks following trickling filters or rotating biological contactors shall not exceed 1200 GPD per square foot based on peak hourly flow.

6.8.3.2. Activated Sludge - The hydraulic design of intermediate and final settling tanks following the activated sludge process shall be based upon the anticipated peak hourly rate for the area downstream of the inlet baffle. The hydraulic loadings shall not exceed: 1200 GPD per square foot

Board of Health
Interpretive Rule 16-1
Series

for conventional, step aeration, contact stabilization and the carbonaceous stage of separate-stage nitrification; 1000 GPD per square foot for extended aeration; and 800 GPD per square foot for the separate nitrification stage. The solids loading for all activated sludge processes shall not exceed 50 lbs. solids per day per square foot at the peak rate.

6.9. Freeboard - Walls of settling tanks shall extend at least 6 inches above the surrounding ground surface and shall provide not less than 12 inches freeboard. Additional freeboard or the use of wind screens is recommended where larger settling tanks are subject to high velocity wind currents that would cause tank surface waves and inhibit effective scum removal.

6.10. Scum Removal - Effective scum collection and removal facilities, including baffling, shall be provided for all settling tanks. The unusual characteristics of scum which may adversely affect pumping, piping, sludge handling and disposal, should be recognized in design. Provisions may be made for the discharge of scum with the sludge; however, other special provisions for disposal may be necessary.

6.11. Sludge Removal - Provisions shall be made to permit continuous sludge removal from settling tanks. Final clarifiers in activated sludge plants greater than 0.25 mgd shall be provided with positive scraping devices. Each sludge withdrawal line shall be at least four inches in diameter, if pumped, and, if gravity flow, at least six inches in diameter and shall be individually valved. This does not apply to air lift methods of sludge removal rate. Head available for withdrawal of sludge shall be at least 30 inches. Adequate provisions shall be made for rodding or back-

Board of Health
Interpretive Rule 16-1
Series

flushing individual pipe runs. Piping shall also be provided to return waste sludge to primary clarifiers.

6.12. Sludge Hopper - The minimum slope of the side walls shall be 1.7 vertical to 1 horizontal. Hopper wall surfaces should be made smooth with rounded corners to aid in sludge removal. Hopper bottoms shall have a maximum dimension of two feet.

7.0. Activated Sludge

7.1. General - The activated sludge process, and its various modifications, may be used where sewage is amenable to biological treatment.

7.2. Settling Tanks - The following requirement is in addition to those set forth in Subsection 6.0. Bypass - When a primary settling tank is used, provision shall also be made for discharging raw sewage directly to the aeration tanks to facilitate plant start-up and operation during the initial stages of the plant design life.

7.3. Aeration

7.3.1. Aeration Tanks

7.3.1.1. General - Multiple tanks capable of independent operation shall be provided for all plants rated at greater than 100,000 GPD. The size of the aeration tank for any particular adaptation of the process shall be based on such factors as the size of the plant, degree of treatment desired, sludge age, mixed liquor suspended solids concentration, BOD loading and food to microorganism ratio. Calculations shall be submitted to justify the basis of the aeration tank capacity and process efficiency. When process design calculations are not submitted, the aeration tank capacities and permissible loadings for the several adaptations of the processes shown in

Board of Health
 Interpretive Rule 16-1
 Series

the following table shall be used. These values apply to plants receiving peak to average daily load ratios ranging from about 2:1 to 4:1. Thus, the utilization of flow equalization facilities to reduce the daily peak organic load may be considered by the director as justification to approve organic loading rates that exceed those specified in Table 2.

Table 2
 PERMISSIBLE AERATION TANK CAPACITIES AND LOADINGS

Process	Aeration Tank Organic Loading—lb. BOD5/day per 1000 cu. ft.	F/M Ratio lb.BOD5/day per lb.MLVSS	MLSS* mg/liter
Conventional Step Aeration Complete Mix	40	0.2-0.5	1000-3000
Contact Stabilization	50**	0.2-0.6	1000-3000
Extended Aeration Oxidation Ditch	15	0.05-0.1	3000-5000

* MLSS values are dependent upon the surface area provided for sedimentation and the rate of sludge return as well as the aeration process.

** Total aeration capacity, includes both contact and reaeration capacities. Normally the contact zone equals 30 to 35% of the total aeration capacity.

7.3.1.2. Arrangement of Aeration Tanks - The dimensions of each independent mixed liquor aeration tank shall be such as to maintain effective mixing and utilization of air. Liquid depths should not be less than 10 feet for plants greater than 100,000 GPD. For very small tanks or tanks with special configuration, the shape of the tank and the installation of aeration equipment should provide for elimination of shortcircuiting through the tank.

7.3.2. Inlets and Outlets - Inlets and outlets for each aeration tank unit shall be suitably equipped with valves, gates, stop plates, weirs or other devices to permit control of the flow and to maintain reasonably constant liquid level. The hydraulic properties of the system shall permit the maximum instantaneous hydraulic load to be carried with any single aeration tank unit out of service.

7.3.3. Conduits - Channels and pipes carrying liquids with solids in suspension shall be designed to maintain self-cleaning velocities or shall be agitated to keep such solids in suspension at all rates of flow within the design limits.

7.3.4. Measuring Devices - For plants designed for greater than 100,000 GPD devices shall be installed for indicating flow rates of influent sewage, return sludge and air to each aeration tank. For plants designed for greater than 1,000,000 GPD, devices shall be installed for totalizing, indicating and recording influent sewage and returned sludge to each aeration tank. Where the design provides for all returned sludge to be mixed with the raw sewage (or primary effluent) at one location, then the mixed liquor flow rate to each aeration unit shall be measured.

7.3.5. Freeboard and Foam Control

Board of Health
Interpretive Rule 16-1
Series

7.3.5.1. Aeration tanks shall have a freeboard of at least 18 inches.

7.3.5.2. Foam control devices shall be provided for aeration tanks on all plants greater than 10,000 gallons in size. Suitable spray systems or other appropriate means will be acceptable. The spray lines shall have provisions for draining to prevent damage by freezing.

7.4. Aeration Equipment

7.4.1. General - Aeration equipment shall be designed to supply sufficient oxygen to maintain a minimum dissolved oxygen concentration of 2 mg/l throughout the mixed liquor at all times. Aeration equipment shall be capable of transferring 1.1 lbs. of oxygen per pound of peak BOD applied to the aeration tank with the exception of the extended aeration process for which the value shall be 1.8. Calculations shall be submitted to justify the oxygen requirements and the aeration equipment capacity for plants greater than 100,000 gallons in size.

7.4.2. Nitrification - In the case of nitrification, the oxygen requirement for oxidizing ammonia must be added to the above requirement for carbonaceous BOD removal. The nitrogen oxygen demand (NOD) shall be taken as 4.6 times the daily peak TKN content of the influent. In addition, the oxygen demands due to recycle flows - heat treatment supernatant, vacuum filtrate, elutriates, etc.- must be considered due to high concentrations of BOD and TKN associated with such flows.

7.4.3. Controls - Variable air controls to aeration basins shall be provided. Time clocks, variable speed devices or variable depth weirs for the blowers or aerators may be used. A 24-hour time clock graduated in 15 minutes intervals shall be provided for all extended aeration plants.

7.4.4. Diffused Air Systems

7.4.4.1. The aeration equipment shall be designed to provide oxygen requirements set forth below.

Minimum Air Requirements:

<u>Process</u>	<u>Cubic Feet of Air Available Per lb. of BOD₅ Load in Aeration Tank</u>
Conventional	1500
Step Aeration	1500
Contact Stabilization	1500
Modified or "High-Rate"	400 to 1500 (depending on BOD ₅ removal expected)
Extended Aeration	2600

7.4.4.2. Air volume requirements shall be added to the requirements above for channels, pumps or other air-use demands.

7.4.4.3. The specified capacity of blowers or air compressors, particularly centrifugal blowers, shall take into account that the air intake temperature may reach 40° C (104° F) or higher and the pressure will be less than atmospheric.

7.4.4.4. The blowers shall be provided in multiple units, for plants

Board of Health
Interpretive Rule 16-1
Series

of a capacity greater than 20,000 GPD in size, so arranged and in such capacities as to meet the maximum air demand with the single largest unit out of service. The design shall also provide for varying the volume of air delivered in proportion to the load demand of the plant.

7.4.4.5. The spacing of diffusers shall be in accordance with the oxygenation requirements through the length of the channel or tank and should be designed to facilitate adjustments of their spacing without major revision to air header piping. The arrangement of diffusers should also permit their removal for inspection maintenance and replacement without dewatering the tank and without shutting off the air supply to other diffusers in the tank.

7.4.4.6. Individual assembly units of diffusers shall be equipped with control valves, preferably with indicator markings for throttling or for complete shut-off. Diffusers in any single assembly shall have substantially uniform pressure loss.

7.4.4.7. Air filters shall be provided to prevent clogging of the diffuser system used and to protect the blower(s).

7.4.5. Mechanical Aeration System

7.4.5.1. The mechanism and drive unit shall be designed for the expected conditions in the aeration tank in terms of the power performance. Certified testing shall verify mechanical aerator performance.

7.4.5.2. A mechanical aeration system shall also accomplish the following:

- A. Maintain all biological solids in suspension.
- B. Meet maximum oxygen demand and maintain process performance with

the largest unit out of service. Where system capacity is greater than 20,000 GPD and where single unit installations are proposed, a spare aeration mechanism shall be provided.

C. Provide for varying the amount of oxygen transferred in proportion to the load demand on the plant.

7.5. Return Sludge Equipment

7.5.1. Return Sludge Rate - The rate of sludge return expressed as a percentage of the average design flow of sewage should generally be variable between the limits shown:

	<u>Minimum</u>	<u>Maximum</u>
Standard Rate	15	75
Carbonaceous Stage of Separate Stage		
Nitrification	15	75
Step Aeration	15	75
Contact Stabilization	50	150
Extended Aeration	50	150
Nitrification Stage of Separate Stage		
Nitrification	50	200

The rate of sludge return shall be varied by means of variable speed motors, drivers, air lifts, or timers, to pump sludge at the above rates.

7.5.2. Return Sludge Pumps - If motor driven return sludge pumps are used, the maximum return sludge capacity shall be obtained with the largest pump out of service. A positive head should be provided on pump suction. Pumps should have at least 3 inch suction and discharge openings. If air lifts are used for returning sludge from each settling tank hopper, no standby unit will be required provided the design of the air lifts are such to facilitate their rapid and easy cleaning and removal and other standby

measures are provided. Air lifts should be at least 3 inches in diameter.

7.5.3. Return Sludge Piping - Discharge piping should be at least 3 inches in diameter and should be designed to maintain a velocity of not less than 2 feet per second when return sludge facilities are operating at normal return sludge rates.

7.5.4. Waste Sludge Facilities - Waste sludge control facilities should have a maximum capacity of not less than 25% of the average rate of sewage flow and function satisfactorily at rates of 0.5 percent of average sewage flow or a minimum of 10 gallons per minute, whichever is larger, for plants greater than 100,000 GPD in size. Aerated sludge holding tanks shall be provided for extended aeration plants from 10,000 to 100,000 GPD in size. Sludge holding tanks shall be designed with a minimum capacity of 10% of the average daily design flow.

8.0. Trickling Filters

8.1. Filters shall be designed so as to provide the reduction in carbonaceous and nitrogenous oxygen demand required, and to properly condition the sewage for subsequent treatment processes. The hydraulic loading on standard rate trickling filters shall be between two and four million gallons per acre per day with an organic loading equal to or less than 400 lbs. of BOD₅ per acre foot per day.

8.2. Dosing Equipment

8.2.1. Distribution - The sewage may be distributed over the filter by rotary distributors or other suitable devices which will permit reasonably uniform distribution to the surface area. At design average flow, the deviation from a calculated uniformly distributed volume per square foot of

the filter surface shall not exceed plus or minus 10 percent at any point.

8.2.2. Dosing - Sewage may be applied to the filters by siphons, pumps, or by gravity discharge preceding treatment units when suitable flow characteristics have been developed. Application of sewage shall be practically continuous. Consideration shall be given to a piping system which will permit recirculation.

8.2.3. Hydraulics - All hydraulic factors involving proper distribution of sewage on the filters shall be carefully calculated. For reaction type distributors, a minimum head of 25 inches between low water level in siphon chamber and center of arms shall be required. Surge relief, to prevent damage to distributor seals, shall be provided where sewage is pumped directly to the distributors.

8.2.4. Clearance - A minimum clearance of six inches between media and distributor arms shall be provided. Greater clearance will be required where icing occurs.

8.3. Media

8.3.1. Quality - The media may be crushed rock, slag, or plastic, or specially manufactured material. The media shall be durable, resistant to spalling or flaking and relatively insoluble in sewage. The top 18 inches shall have a loss by the 20-cycle, sodium sulfate soundness test of not more than 10%, as prescribed by ASCE Manual of Engineering Practice No. 13, "Filtering Materials for Sewage Treatment Plants". The balance to pass a 10-cycle test using the same criteria. Slag media shall be free from iron. Manufactured media shall be structurally stable and chemically and biologically inert.

Board of Health
Interpretive Rule 16-1
Series

8.3.2. Rock or slag filter media shall have a minimum depth of 5 feet above the underdrains. Manufactured filter media should have a minimum depth of 10 feet to provide adequate contact time with the wastewater. Rock or slag filter media depths shall not exceed 10 feet and manufactured filter media depths shall not exceed 30 feet.

8.3.3. Size and Grading

8.3.3.1. Rock, Slag, and Similar Media - Shall not contain more than five percent by weight of pieces whose longest dimension is three times the least dimension. They shall be free from thin elongated flat pieces, dust, clay, sand or fine material and shall conform to the following size and grading when mechanically graded over vibrating screens with square openings:

Passing 4½-inch screen	100% by weight
Retained on 3-inch screen	95-100% by weight
Passing 2-inch screen	0-2% by weight
Passing 1-inch screen	0-1% by weight

8.3.3.2. Hand Picked Field Stone - Maximum dimensions of stone-five inches; Minimum dimensions of stone-three inches

8.3.3.3. Manufactured Media - Applications of manufactured media will be evaluated on a case-by-case basis.

8.3.3.4. Handling and Placing of Media - Material delivered to the filter site shall be stored on wood planks or other approved clean, hard surfaced areas. All material shall be rehandled at the filter site and no

Board of Health
Interpretive Rule 16-1
Series

material shall be dumped into the filter. Crushed rock, slag, and similar media shall be rescreened or forked at the filter site to remove all fines. Such material shall be placed by hand to a depth of 12 inches above the tile so as not to damage the underdrains. The remainder of the material may be placed by the engineer. Manufactured media shall be handled and placed as approved by the engineer. Trucks, tractors, or other heavy equipment shall not be driven over the filter during or after construction.

8.4. Underdrainage System

8.4.1. Arrangement - Underdrains with semi-circular inverts shall be provided and the underdrainage system shall cover the entire floor of the filter. Inlet openings into the underdrains shall have an unsubmerged gross combined area equal to at least 15% of surface area of the filter.

8.4.2. Slope - The underdrains shall have a minimum slope of 1%. Effluent channels shall be designed to produce a minimum velocity of two feet per second at average daily rate of application to the filter.

8.4.3. Flushing - Provision shall be made for flushing the underdrains. The use of a peripheral head channel with vertical vents is acceptable for flushing purposes. Inspection facilities shall be provided.

8.4.4. Ventilation - The underdrainage system, effluent channels and effluent pipe shall be designed to permit free passage of air. The size of drains, channels, and pipe shall be such that not more than 50% of their cross-sectional area will be submerged under the design hydraulic loading. Provision shall be made in the design of the effluent channels to allow the possibility of increased hydraulic loading.

8.5. Special Features

Board of Health
Interpretive Rule 16-1
Series

8.5.1. Flooding - Provisions shall be made in the design of filter structures so that they may be flooded.

8.5.2. Maintenance - All distribution devices, underdrains, channels and pipes shall be installed so that they may be properly maintained, flushed, or drained.

8.5.3. Freeboard - A freeboard of four feet or more should be provided for tall, manufactured media filters to minimize windblown spray.

8.5.4. Flow Measurement - Devices shall be provided to permit measurement of flow to filter, including recirculated flows.

8.5.5. Recirculation - Consideration should be given to the merits of recirculation for various purposes; for example, to prevent drying of a standard rate filter between dosings.

8.6. Two-Stage Filters - Consideration should be given to the use of two-stage filters where single stage filters may not accomplish the required removals.

8.7. Efficiencies - Expected efficiencies shall be calculated and documented. Consideration shall be given to the effect of climatic conditions on the overall filter performance.

8.8. Rotary Distributor Seals - Mercury seals will not be permitted. Ease of seal replacement shall be considered in design.

9.0. Rotating Biological Contactors (RBC's)

9.1. Winter Protection - Year round operation requires that rotating contactors be covered to protect the biological growth from cold temperatures and the excessive loss of heat from the wastewater with the resulting loss of performance. Enclosures shall be constructed of a suitable

Board of Health
Interpretive Rule 16-1
Series

corrosion resistant material. Windows or simple louvered mechanisms which can be opened in the summer and closed in the winter shall be installed to provide ventilation. To minimize condensation, the enclosure should be insulated or heated.

9.2. Required Pretreatment - RBC's must be preceded by primary settling tanks equipped with scum and grease collecting devices. Bar screening or comminution are not suitable as the sole means of pretreatment.

9.3. Unit Sizing - Unit sizing shall be based on experience at similar full-scale installations or thoroughly documented pilot testing with the particular wastewater. In determining design loading rates, expressed in units of volume per day per unit area of media covered by biological growth, the following parameters must be considered:

- 9.3.1. Design flow rate and influent waste strength;
- 9.3.2. Percentage of BOD to be removed;
- 9.3.3. Media arrangement, including number of stages and unit area in each stage;
- 9.3.4. Rotational velocity of the media;
- 9.3.5. Retention time within the tank containing the media;
- 9.3.6. Wastewater temperature; and
- 9.3.7. Percentage of influent BOD which is soluble.

In addition to the above parameters, loading rates for nitrification will depend upon influent total Kjeldahl nitrogen (TKN), influent ammonia nitrogen concentration, pH, and the allowable effluent ammonia nitrogen concentration.

9.4. Design Safety Factor - Effluent concentrations of ammonia

nitrogen from the RBC process designed for nitrification are affected by daily load variations. Therefore, it may be necessary to increase the design surface area proportional to the ammonia nitrogen daily peaking rates to meet effluent limitations. An alternative is to provide flow equalization sufficient to insure process performance within the required effluent limitations.

10.0 Other Biological & Mechanical Systems

New Biological & Mechanical Treatment Schemes - With promising applicability in wastewater treatment may be considered if the required engineering data for new process evaluation is provided in accordance with Subsection 1.3.3.

11.0. Sewage Stabilization Ponds, Anaerobic Lagoons, and Aerated Lagoons

11.1. General - Stabilization ponds, anaerobic lagoons, and aerated lagoons may be used for treatment of raw sewage, primary sewage effluent or secondary sewage effluent.

11.2. Stabilization Ponds

11.2.1. Location - Stabilization ponds of 4 acres and larger shall be located a minimum of 1500 feet from the nearest occupied structure. Stabilization ponds of less than 4 acres in size may be located as close as 300 feet to the nearest occupied structure. These distance requirements may be waived upon releases being obtained from the neighboring property owners.

11.2.1.1. Wind Sweep - Stabilization ponds shall be located to permit an unobstructed wind sweep across the ponds.

11.2.1.2. Water Supply - Stabilization ponds shall be located a

Board of Health
Interpretive Rule 16-1
Series

minimum of 100 feet from a drinking water supply. A minimum distance of 200 feet shall be maintained if the supply is down gradient from or lower in elevation than the bottom of the pond.

11.2.2. Geology and Soils - Borings to determine surface and sub-surface characteristics of the pond site shall be obtained for all ponds greater than 2.5 acres in size or where required by the director. A soil report from the Soil Conservation Service, U.S. Department of Agriculture, is required for all pond sites.

11.2.3. Pond Shape - The shape of all ponds should be such as to produce a uniform perimeter with no coves, islands or peninsulas permitted. Corners of ponds shall be rounded. The most desirable shape is round, square or rectangular with the length not exceeding three times the width.

11.2.4. Design

11.2.4.1. Loading - Stabilization ponds shall be designed on the basis of 34 pounds per day of five-day BOD per acre.

11.2.4.2. Ponds in Series - If one or more ponds are added in series with the primary pond, the primary pond shall have a surface area equal to that required in Subsection 11.2.4.1.

11.2.4.3. Pretreatment - Where stabilization ponds follow some type of conventional treatment facility, reduction of the pond loading as set forth in Subsection 11.2.4.1 may be considered on a case-by-case basis.

11.2.4.4. Depth - Liquid depth of ponds shall be no less than 3½ feet or greater than 5 feet. A 3 foot minimum freeboard shall be provided.

11.2.5. Influent Lines

11.2.5.1. Location of Discharge - Influent lines shall discharge at

Board of Health
Interpretive Rule 16-1
Series

the one-third point of the primary stabilization pond. Ponds following the primary pond or secondary treatment facilities in multiple unit systems shall be edge discharging.

11.2.5.2. Gravity - Influent lines from gravity collection systems shall discharge at a point 12 to 18 inches above the pond surface.

11.2.5.3. Pressure - Pressure influent lines may discharge either above the pond surface or at a point one foot above the pond bottom. When discharging below the pond surface, the end of the pressure line shall rest upon a concrete apron of two square feet minimum size.

11.2.5.4. Pipe Support - Influent lines shall be supported on piers or other open structures. Dikes for pipe support will not be permitted.

11.2.6. Pond Details

11.2.6.1. Embankments - Embankments shall be constructed of compacted impervious materials with a minimum top width of 8 feet. All vegetation shall be removed from the area upon which the embankment is to be placed.

11.2.6.2. Slope - Embankment slopes shall not be steeper than 2 horizontal to 1 vertical. Minimum slopes shall not be flatter than four horizontal to one vertical.

11.2.6.3. Pond Bottom - Pond bottoms shall be level and cleared of all vegetation and debris.

11.2.6.4. Watertightness - If soil characteristics are such that seepage will take place, ponds shall be made watertight through use of a pond liner of man-made materials or clay or through use of a soil additive. Lining, if required, shall be of the thickness recommended by the manufacturer, or a six-inch minimum of natural materials.

Board of Health
Interpretive Rule 16-1
Series

11.2.7. Effluent Lines

11.2.7.1. Discharge - The effluent line shall be designed to discharge from a point 18 inches below the surface of the pond. The effluent line may be vented to prevent siphoning. The effluent line shall discharge on a concrete slab or rip-rap apron. Effluent lines shall be placed at the furthest point from the influent line discharge.

11.2.7.2. Discharge Structure - For ponds greater than 2.5 acres in size, discharge structures capable of variable depth control shall be provided. Depth shall be adjustable between 3.5 and 5 feet in increments of 0.5 foot or less. Withdrawal points shall be spaced from 18 inches below the surface to 12 inches above the pond bottom discharge structures. These structures shall be placed at a point furthest from the influent line discharge and be readily accessible from the embankment.

11.2.8. Recirculation - Recirculation should be considered for multiple pond facilities. Whenever recirculation is proposed, and pond size is thereby reduced, calculations justifying the proposed reduction shall be submitted to the director for approval.

11.2.9. Drain Lines - Drain lines shall not be permitted.

11.2.10. Miscellaneous

11.2.10.1. Surface Runoff - Provision shall be made to divert storm and surface water around stabilization ponds.

11.2.10.2. Fencing - Ponds shall be enclosed with a stock-tight fence a minimum of six feet in height with a locked entrance gate.

11.2.10.3. Signs - Several signs stating the nature of the facility shall be installed on the fence.

Board of Health
Interpretive Rule 16-1
Series

11.2.10.4. Prefilling - Stabilization ponds shall be prefilled to a minimum depth of two feet prior to use.

11.2.10.5. Access Road - An all-weather access road shall be provided to the pond site.

11.3. Anaerobic Lagoons

11.3.1. General - Anaerobic lagoons are normally used for animal waste treatment.

11.3.2. Location - Anaerobic lagoons shall be located a minimum of 1500 feet from the nearest occupied structure.

Water Supply - Distance from a drinking water supply shall comply with Subsection 11.2.1.2.

11.3.3. Geology and Soils - Shall comply with Subsection 11.2.2.

11.3.4. Lagoon Shape - Shall comply with Subsection 11.2.3.

11.3.5. Design - Design shall comply with West Virginia Standard for Disposal Lagoon (359) published October, 1972, by the Soil Conservation Service USDA.

11.4. Aerated Lagoons

11.4.1. General - Aerated lagoon sewage treatment facility shall consist of the following:

11.4.1.1. Pretreatment.

11.4.1.2. Aeration basin.

11.4.1.3. Settling basin, if required.

11.4.1.4. Supplementary treatment, if required.

11.4.2. Location - Aerated lagoons shall be located a minimum of 300 feet from the nearest occupied structure.

Board of Health
Interpretive Rule 16-1
Series

11.4.3. Water Supply - Distance from a drinking water supply shall comply with Subsection 11.2.1.2.

11.4.4. Geology and Soils--Shall comply with Subsection 11.2.2.

11.4.5. Shape - Shall comply with Subsection 11.2.3.

11.4.6. Design

11.4.6.1. Method - The design of aeration basins is normally based upon the aerated lagoon theory using a K_e of 0.5 (at 20°C). Formulas to be used are:

$$t = \frac{\% \text{ removal}}{(100 - \% \text{ removed}) K_T} = \text{days detention}$$

$$(100 - \% \text{ removed}) K_T$$

$$\text{where: } K_T = 0.5 (1.075)^{T-20}$$

T = average year-round air temperature at the site in °C.

The dissolved oxygen level should be a minimum of 2 ppm and ratio of oxygen transfer should be assumed at (0.9). The oxygen requirement should be based upon 1.5 pounds/pound of BOD₅ to be removed.

11.4.6.2. Depth - The aeration basin shall be of a depth ranging from six to 15 feet. Air shall be supplied to the aeration basin by means of surface aerators or subsurface air diffusers. Basins shall be designed to distribute oxygen throughout, but not to keep solids in suspension.

11.4.6.3. Settling - A settling pond shall follow the aeration basin. The settling pond shall be sized based upon BOD₅ remaining after aeration at the loading rate of 34 pounds of BOD₅ per surface acre/day.

11.4.6.4. Lagoon Details - Lagoon shape, dikes, embankments, construction and effluent lines shall comply with Subsections 11.2.6 thru 11.2.10.

Board of Health
Interpretive Rule 16-1
Series

12.0. Disinfection

12.1. General - All sewage treatment plant effluents shall be adequately disinfected prior to discharge.

12.2. Chlorination

12.2.1. Chlorine Terminology - Unless otherwise indicated the word "chlorine" wherever used in this section refers to dry chlorine.

12.2.2. Equipment

12.2.2.1. Feed Equipment Type - Solution-feed vacuum-type chlorinators are generally preferred for plants greater than 100,000 GPD in size. The use of hypochlorite solution feeders of the positive displacement type may be considered. For plants of 100,000 GPD or less in size, tablet type chlorinators may be used.

12.2.2.2. Feed Equipment Capacity - Chlorinator capacities required will vary, depending on the use and point of application of the chlorine. For disinfection, the capacity shall be such to produce a residual of 0.5 ppm maximum in the final effluent at peak flow rates.

12.2.2.3. Chlorination Equipment and Spare Parts - An inventory of parts subject to wear and breakage shall be maintained at all times. Dual chlorinators are required for plants over 100,000 GPD in size. Each chlorinator must be able to provide the required chlorination at peak flow rates.

12.2.2.4. Water Supply - A supply of water shall be available for operating the chlorinators. Where a booster pump is required, duplicate pumping equipment shall be provided. When connection is made from domestic water supplies, equipment for backflow prevention shall be provided. Pres-

Board of Health
Interpretive Rule 16-1
Series

sure gauges shall be provided on chlorinator water supply lines.

12.2.2.5. Measurement Equipment - Equipment for measuring the amount of chlorine use shall be provided.

12.2.2.6. Evaporators - Where manifolding of several cylinders will be required to feed sufficient chlorine, consideration shall be given to the installation of evaporators.

12.2.2.7. Leak Detection and Controls - A bottle of ammonium hydroxide solution shall be available for detecting chlorine leaks. Consideration shall also be given to the provision of caustic soda solution reaction tanks for absorbing the contents of leaking 1-ton cylinders where such cylinders are in use.

12.2.3. Piping and Connections

12.2.3.1. General - Piping systems shall be well supported, adequately sloped to allow drainage and protected from mechanical damage. Suitable allowance shall be provided for pipe expansion due to changes in temperature.

12.2.3.2. Condensation - Where adequate superheat is not provided by a vaporizer, condensation should be prevented by reducing the pressure with a pressure reducing valve.

12.2.3.3. Chlorine solution piping shall be arranged such that pre- and post-chlorination may be accomplished by any or all chlorinators.

12.2.4. Housing

12.2.4.1. Building - Any building to house chlorine equipment or containers shall be designed and constructed to protect all elements of the chlorine system from fire hazards. If flammable materials are stored or

Board of Health
Interpretive Rule 16-1
Series

processed in the same building with chlorination equipment other than that utilizing hypochlorite solutions, a fire wall shall be erected to separate the two areas.

If gas chlorination equipment and chlorine cylinders are to be in a building used for other purposes, a gas-tight partition shall separate this room from any other portion of the building. Doors to this room shall be equipped with panic hardware. Such rooms shall be at ground level and shall permit easy access to all equipment. Storage area should be separated from the feed area. No basement shall be permitted.

Means of exit to the outside of the building should be provided from each separate room or building in which chlorine, other than hypochlorite, is stored, handled or used.

A clear glass, gas-tight window shall be installed in an exterior door or interior wall of the chlorinator room to permit the chlorinator to be viewed without entering the room.

12.2.4.2. Heat - Chlorinator rooms shall be provided with a means of heating so that a temperature of at least 60°F can be maintained. The room shall also be protected from excess heat.

12.2.4.3. Ventilation - Forced, mechanical ventilation which will provide one complete air change per minute shall be installed in all chlorine feed rooms and rooms where chlorine cylinders are stored. The entrance to the air exhaust duct from the room shall be near the floor and the point of discharge shall be so located as not to contaminate the air inlets to any building or inhabited areas. Air inlets shall be so located as to provide cross ventilation with air and at such a temperature that will not adversely

Board of Health
Interpretive Rule 16-1
Series

affect the chlorination equipment. The vent hose shall run without traps from the chlorinator and shall discharge to the outside atmosphere above grade.

12.2.4.4. Electrical Controls - The controls for the fans and lights shall be such that they will automatically operate when the door is opened and can also be manually operated from the outside without opening the door.

12.2.5. Respiratory Protection - Respiratory air-pac protection equipment, meeting the requirements of the National Institute for Occupational Safety and Health (NIOSH), shall be available where chlorine gas is handled, and shall be stored at a convenient location, but not inside any room where chlorine is used or stored. Instructions for using the equipment shall be posted. The units shall use compressed air, have a least 30-minute capacity, and be compatible with the units used by the fire department responsible for the plant.

12.2.6. Application of Chlorine

12.2.6.1. Mixing With Flow - Provisions shall be made to ensure uniform mixing of the chlorine solution with the wastewater flow near the point of application.

12.2.6.2. Contact Period - A minimum contact period of 40 minutes at average daily flow or 15 minutes at maximum daily flow shall be provided. Additional contact time may be required if the discharge point is in proximity to a water supply intake, recreational area or some other similar area.

12.2.6.3. Contact Tank - Chlorine contact tanks shall be designed to minimize "short-circuiting" of flow.

Board of Health
Interpretive Rule 16-1
Series

Over and under, or end-around baffling shall be provided. Air lift sludge returns from the contact tank are required for all extended aeration sewage treatment plants 10,000 GPD or greater in size unless preceded by a filter or polishing pond. Multiple units shall be required for plants over 100,000 gallons in size.

12.2.7. Dechlorination - The removal of all or part of the chlorine residual may be required prior to final discharge, to meet the adopted stream standards or other requirements for particular streams.

12.3. Other Methods - The use of other methods for disinfection will be evaluated on a case-by-case basis. As a minimum, the following shall be investigated when other methods are to be utilized for disinfection:

12.3.1. Minimum effluent conditions, such as clarity, soluble organics and pH required for adequate disinfection.

12.3.2. Methods for dispersion and mixing with the waste stream.

12.3.3. Other factors, including but not limited to, equipment reliability, safety and application rates required for varying waste flows.

12.3.4. Refer to Subsection 1.3.3.

12.4. Evaluation of Effectiveness

12.4.1. Sampling - Facilities shall be included for securing a sample prior to discharge to determine the effectiveness of the disinfection method.

12.4.2. Residual Chlorine Testing and Control - When chlorine is used for disinfection, equipment shall be provided for measuring chlorine residual. Where the discharge occurs in critical areas, the installation of facilities for continuous automatic chlorine residual analysis, recording

and proportioning systems may be required.

13.0. Supplementary Treatment

13.1. General - Supplementary treatment shall be required when health considerations or waste load allocations and effluent limitations require treatment more stringent than secondary.

13.2. Alternating Surface Sand Filters

13.2.1. General - Alternating surface sand filters normally shall be used for plants of 100,000 GPD or less in size. Alternating surface sand filters may be permitted for plants of over 100,000 GPD in size on a case-by-case basis.

13.2.2. Filter Rate - An alternating sand filter shall be designed for a filter rate of not more than 20 gallons per square foot per day.

13.2.3. Application - Effluent shall be applied with either a pump or siphon chamber designed to dose all sections of the filter equally with three to four inches of liquid or, where elevation differences permit, gravity application of effluent to the filter may be permitted, if uniform distribution of effluent is provided.

13.2.4. Location - Alternating surface sand filters shall not be located within 100 feet of the nearest occupied residence or habitation. This distance requirement may be waived in the event a release is obtained from the neighboring property owner(s).

13.2.5. Media - The sand used in alternating surface sand filters shall be coarse, clean sand of uniform size. Other media may be approved on a case-by-case basis. (Effective size of 0.3 to 0.6 mm in diameter with a uniformity Coefficient of no greater than 4.0).

Board of Health
Interpretive Rule 16-1
Series

13.2.6. Construction - These walls and bottom of the sand filters shall be impermeable.

13.2.7. Disinfection - Disinfection will be required after the filters and before discharge to a stream.

13.3. High Rate Effluent Filtration

13.3.1. General - High rate filters may be either gravity or pressure.

13.3.1.1. Gravity - The use of gravity high rate filters shall be limited to plants of 40,001 GPD or more in size, unless insufficient area is to permit the use of other types of supplementary treatment (Example: alternating surface sand filters or polishing ponds).

13.3.1.2. Pressure - The use of pressure high rate filters shall be limited to plants of greater than 100,000 gallons per day in size.

13.3.2. Filtration Rates - Allowable rates for gravity filters shall not be greater than one (1) gallon per minute per square foot per day. Filtration rates for pressure filters shall not be greater than five gallons per minute per square foot per day. Rates are based upon the maximum flow rate applied.

13.3.3. Number of Units - Total filter area shall be provided in two or more units, and the filtration rate shall be calculated on the total available filter area with one unit out of service.

13.3.4. Backwash - Backwash shall include either air scouring or positive surface wash. Filtered effluent shall be used for backwash and waste filter backwash water shall be returned to the head of the plant.

13.3.4.1. Backwash Water Storage - Total backwash water storage

Board of Health
Interpretive Rule 16-1
Series

capacity required shall equal or exceed one complete backwash cycle.

13.3.4.2. Backwash Rate - The backwash rate shall not exceed 20 gallons per minute per square foot with a minimum backwash period of 10 minutes.

13.3.4.3. Pumps - Pumps for backwashing filter units shall be sized and interconnected to provide the required rate to any filter with the largest pump out of service.

13.3.5. Proprietary Equipment - Where proprietary filtration equipment not conforming to the preceding requirements is proposed, data which supports the capability of the equipment to meet effluent requirements under design conditions shall be provided. Such equipment will be considered on a case-by-case basis by the director.

13.4. TKN Removal

13.4.1. General - TKN removal shall be considered when the total Kjeldahl nitrogen limit as stated in the discharge load allocation is less than 18 mg/l.

13.4.2. Methods - Methods which may be used to achieve TKN removal may include, but not be limited to: additional aeration in extended aeration plants; separate stage nitrification; break-point chlorination; nitrification column; and alternating surface sand filters.

13.4.3. Limitations - TKN removal is temperature dependent. Therefore, consideration should be given to the use of winter-summer discharge load allocations.

13.5. Microscreening

13.5.1. General - Microscreening units may be used following a bio-

Board of Health
Interpretive Rule 16-1
Series

logical treatment process for the removal of residual suspended solids.

13.5.2. Materials - Microscreen shall be either a specially woven polyester or stainless steel with aperture size of 20-30 microns.

13.5.3. Design - The hydraulic loading shall not be greater than ten gallons per minute per square foot of submerged drum surface. Maximum head loss shall be 12-18 inches. An overflow weir shall be provided to by-pass part of the flow when head exceeds six to eight inches. It is recommended that drums be not less than 10 feet in diameter.

13.5.4. Backwash - Continuous pressureized (60 psig) backwash shall be applied at a minimum rate of eight gallons per minute per square foot of screen. Dual backwash pumps shall be provided, each pump being capable of supplying 100% of the required flow. Backwash water shall be returned to the head of the plant at a rate not to exceed 15% of the average daily design flow.

13.5.5. Reliability - Dual microscreen units shall be provided, each unit being capable of providing 100% of the design microscreen capacity. Automatic drum speed controls with provision for manual override shall be provided for each screen. All units shall be enclosed in a heated and ventilated structure.

13.6. Polishing Ponds

13.6.1. General - Polishing ponds shall be designed in accordance with Subsection 11.2. Polishing ponds shall have a capacity of at least 65,000 gallons or capacity for a detention time of 10 days plant design flow, whichever is greater.

13.6.2. Distance Requirements - Polishing ponds shall be located at

least 100 feet from the nearest occupied structure.

13.7. Post Aeration - A discharge load allocation of 6.0 milligrams per liter dissolved oxygen shall be met by means of one of the following:

13.7.1. Post aeration tank with air added by diffusion or mechanical means.

13.7.2. Cascade aeration.

13.7.3. Polishing ponds are considered to provide the dissolved oxygen requirements.

14.0. Sludge Handling and Disposal

14.1. Anaerobic Sludge Digestion

14.1.1. Multiple Units - Multiple tanks are recommended. Where a single digestion tank is used, an alternate method of sludge processing or emergency storage to maintain continuity of service shall be provided.

14.1.2. Depth - For those units proposed to serve as supernatant separation tanks, the depth shall be sufficient to allow for the formation of a reasonable depth of supernatant liquor. A minimum sidewater depth of 10 feet is recommended.

14.1.3. Maintenance Provisions - To facilitate draining, cleaning, and maintenance, the following features are desirable.

14.1.3.1. Slope - The tank bottom should slope to drain toward the withdrawal pipe. For tanks equipped with a suction mechanism for withdrawal of sludge, a bottom slope not less than 1:12 is recommended. Where the sludge is to be removed by gravity alone, 1:4 slope is recommended.

14.1.3.2. Access Manholes - At least two 36-inch diameter access manholes should be provided in the top of the tank in addition to the gas

dome. There should be stairways to reach the access manholes. A separate sidewall manhole shall be provided. The opening should be large enough to permit the use of mechanical equipment to remove grit and sand.

14.1.3.3. Safety - Nonsparking tools, safety lights, rubber-soled shoes, safety harness, gas detectors for inflammable and toxic gases, and at least two self-contained breathing units shall be provided for emergency use.

14.1.4. Sludge Inlets and Outlets

14.1.4.1. Recirculation - Multiple recirculation withdrawal and return points, should be provided, unless mixing facilities are incorporated within the digester. The return shall discharge above the liquid level and be located near the center of the tank.

14.1.4.2. Raw Sludge Discharge - Raw sludge discharge to the digester should be through the sludge heater and recirculation return piping, or directly to the tank if internal mixing facilities are provided.

14.1.4.3. Withdrawal - Sludge withdrawal to disposal shall be from the bottom of the tank. This pipe shall be interconnected with the recirculation piping.

14.1.5. Tank Capacity - The total digestion tank capacity should be determined by rational calculations based upon such factors as volume of sludge added, its percent solids and character, the temperature to be maintained in the digesters, the degree or extent of mixing to be obtained, and the degree of volatile solids reduction required. Calculations shall be submitted to justify the basis of design.

When such calculations are not based on the above factors, the minimum

where gas is produced. Pressure and vacuum relief valves and flame traps, together with automatic safety shutoff valves, shall be provided. Water seal equipment shall not be permitted. Gas safety equipment and gas compressors shall be housed in a separate room with an exterior entrance.

14.1.6.3. Gas Piping and Condensate - Gas piping shall be of adequate diameter and shall slope to condensate traps at low points. The use of float-controlled condensate traps is not permitted.

14.1.6.4. Gas Utilization Equipment - Gas-fired boilers for heating digesters shall be located in a separate room not connected to the digester gallery.

14.1.6.5. Electrical Fixtures - Electrical fixtures and controls, in places enclosing anaerobic digestion appurtenances, where hazardous gases are normally contained in the tanks and piping, shall comply with the National Electrical Code for Class 1, Group D, Division 2 locations. Digester galleries should be isolated from normal operating areas, to avoid an extension of the hazardous location.

14.1.6.6. Waste Gas - Waste gas burners shall be readily accessible and should be located at least 25 feet away from any plant structure if placed at ground level, or may be located on the roof of the control building if sufficiently removed from the tank.

All waste gas burners shall be equipped with automatic ignition, such as a pilot light or a device using a photoelectrical cell sensor. Consideration should be given to the use of natural or propane gas to insure reliability of the pilot light.

In remote locations it may be permissible to discharge the gas to the

atmosphere through a return-bend screened vent terminating at least 10 feet above the ground surface, provided that the assembly incorporates a flame trap.

14.1.6.7. Ventilation - Any underground enclosures connecting with digestion tanks or containing sludge or gas piping or equipment shall be provided with forced ventilation. The piping gallery for digesters shall not be connected to other passages. Where used, tightly fitting, self-closing doors shall be provided at connecting passageways and tunnels to minimize the spread of gas.

14.1.6.8. Meter - A gas meter with bypass shall be provided to meter total gas production.

14.1.7. Digester Heating

14.1.7.1. Insulation - Wherever possible, tanks should be constructed above ground water level and shall be suitably insulated to minimize heat loss.

14.1.7.2. Heating Facilities - Sludge may be heated by circulating the sludge through external heaters or by heating units located inside the digestion tank.

A. Piping for external heating shall be designed to provide for the preheating of feed sludge before introduction to the digesters. Provisions shall be made in the layout of the piping and valving to facilitate cleaning of these lines. Heat exchanger sludge piping should be sized for heat transfer requirements.

B. Other Heating Methods: Other types of heating facilities will also be considered on their own merits.

14.1.7.3. Heating Capacity - Heating capacity sufficient to consistently maintain the design sludge temperature shall be provided.

Where digester tank gas is used for sludge heating, an auxiliary fuel supply is required.

14.1.7.4. Hot Water Internal Heating Controls

A. An automatic mixing valve shall be provided to temper the boiler water with return water so that the inlet water to the heat jacket can be held below a temperature at which caking will be accentuated. Manual control shall also be provided by bypass valves.

B. The boiler should be provided with automatic controls to maintain the boiler temperature at approximately 180°F to shut off the main gas supply in the event of pilot burner or electrical failure, low boiler water level, or excessive temperature.

C. Thermometers shall be provided to show temperatures of the sludge, hot water feed, hot water return, and boiler water.

14.1.8. Supernatant Withdrawal

14.1.8.1. Piping Size - Supernatant piping shall not be less than six inches in diameter.

14.1.8.2. Withdrawal

A. Piping should be arranged so that withdrawal can be made from three or more levels in the digester. A positive unvalved vented overflow shall be provided.

B. If a supernatant selector is provided, provisions shall be made for at least one other drawoff level located in the supernatant zone of the tank in addition to the unvalved emergency supernatant drawoff pipe. High

pressure backwash facilities shall be provided.

14.1.8.3. Sampling - Provisions shall be made for sampling at each supernatant drawoff level. Sampling pipes shall be at least 1- $\frac{1}{2}$ inches in diameter, and shall terminate at a suitably-sized sampling sink or basin.

14.1.8.4. Alternate Supernatant Disposal - Consideration should be given to supernatant conditioning, where appropriate, in relation to its effect on plant performance and effluent quality.

14.2. Aerobic Sludge Digestion

14.2.1. General - Aerobic digestion can be used to stabilize secondary sludge. Digestion is accomplished in single or multiple tanks, designed to provide effective air mixing, reduction of the organic matter, supernatant separation, and sludge concentration under controlled conditions.

14.2.2. Digestion Tanks - Multiple tanks are recommended. A single sludge digestion tank may be used in the case of small treatment plants or where provision is made for sludge handling and where a single unit will not adversely affect normal plant operations.

14.2.3. Mixing and Air Requirements - Aerobic sludge digestion tanks shall be designed for effective mixing by aeration equipment. Sufficient air shall be provided to keep the solids in suspension and maintain dissolved oxygen between one and two milligrams per liter. A minimum mixing and oxygen requirement of 30 cfm per 1,000 cubic feet of tank volume shall be provided with the largest blower out of service. If diffusers are used, the nonclog type is required, and they shall be designed to permit continuity of service. If mechanical aerators are utilized, a minimum of 1.0

horsepower per 1,000 cubic feet shall be provided. Use of mechanical equipment is discouraged where freezing temperatures are normally expected.

14.2.4. Tank Capacity - The determination of tank capacities shall be based on rational calculations, including such factors as quantity of sludge produced, sludge characteristics, time of aeration, and sludge temperature.

14.2.4.1. Volatile Solids Loading - The volatile suspended solids loading shall not exceed 100 pounds per 1,000 cubic feet of volume per day in the digestion units. Lower loading rates may be necessary depending on temperature, type of sludge, and other factors.

14.2.4.2. Solids Retention Time - Required minimum solids retention time for stabilization of biological sludges varies depending on type of sludge. Normally a minimum of 15 days retention should be provided for waste activated sludge and 20 days for combination of primary and waste activated sludge, or primary sludge alone. Where sludge temperature is lower than 50°F, additional detention time should be considered.

14.2.5. Supernatant Separation - Facilities shall be provided for separation and withdrawal of supernatant and for collection and removal of scum and grease.

14.2.6. Sludge Thickening - Prior to placement on sludge drying beds, all sludge produced by the activated sludge process shall be conditioned to a minimum solids content of 2% by weight.

14.3. Sludge Pumps and Piping

14.3.1. Sludge Pumps

14.3.1.1. Duplicate Units - Duplicate units shall be provided.

14.3.1.2. Type - Plunger pumps, screw feed pumps, recessed impeller

type centrifugal pumps, progressive cavity pumps, or other types of pumps capable of solids handling shall be provided for handling raw sludge.

14.3.1.3. Minimum Head - A minimum positive head of 24 inches shall be provided at the suction side of centrifugal-type pumps and is desirable for all types of sludge pumps. Maximum suction lifts shall not exceed 10 feet for plunger pumps.

14.3.1.4. Sampling Facilities - Unless sludge sampling valves shall be installed at the sludge pumps. The size of valve and piping shall be at least 1- $\frac{1}{2}$ inches.

14.3.2. Sludge Piping

14.3.2.1. Size and Head - Sludge withdrawal piping shall have a minimum diameter of 8 inches for gravity withdrawal and 6 inches for pump suction and discharge lines. Where withdrawal is by gravity, the available head on the discharge pipe should be adequate to provide at least 3.0 feet per second velocity.

14.3.2.2. Slope - Gravity piping shall be laid on uniform grade and alignment. The slope of gravity discharge piping should not be less than 3%. Provisions shall be made for cleaning, draining, and flushing discharge lines.

14.3.2.3. Supports - Special consideration shall be given to the corrosion resistance and continuing stability of supporting systems located inside the digestion tank.

14.4. Sludge Dewatering

14.4.1. Sludge Drying Beds - The sizing of the drying bed shall be estimated on the basis of 2.0 ft² capita when the drying bed is the primary

method of dewatering, and 1.0 ft² capita if it is to be used as a back-up dewatering unit. An increase of bed area by 25% is recommended for paved beds.

14.4.2. Design

14.4.2.1. Gravel - The lower course of gravel around the underdrains should be graded and shall be 12 inches in depth, extending at least 6 inches above the top of the underdrains. It is desirable to place this in two or more layers. The top layer of at least three inches should consist of gravel 1/8 inch to 1/4 inch in size.

14.4.2.2. Sand - The top course shall consist of 6 to 9 inches of clean washed coarse sand. (Effective size of 0.3 to 0.6 mm in diameter with a uniformity coefficient of no greater than 4.0) The finished sand surface shall be level.

14.4.2.3. Underdrains - Underdrains shall be at least four inches in diameter. Underdrains shall be spaced not more than 20 feet apart.

14.4.2.4. Partially Paved Type - The partially paved drying bed shall be designed with consideration for space requirement to operate mechanical equipment for removing the dried sludge.

14.4.2.5. Walls - Walls shall be watertight and extended 15 to 18 inches above and at least 6 inches below the surface. Outer walls shall be curbed to prevent soil from washing onto the beds.

14.4.2.6. Sludge Removal - Not less than two beds shall be provided and they shall be arranged to facilitate sludge removal. Concrete truck tracks should be provided for all percolation-type sludge beds.

14.4.2.7. Sludge Influent - The sludge pipe to the drying beds shall

terminate at least 12 inches above the surface and be so arranged that it will drain. Concrete splash plates for percolation-type beds shall be provided at sludge discharge points.

14.4.2.8. Protective Enclosure - A protective enclosure should be considered if winter operation is required.

14.4.3. Mechanical Dewatering Facilities - Provision shall be made to maintain continuity of service so that sludge may be dewatered without accumulation beyond storage capacity. The number of vacuum filters, centrifuges, filter presses, belt filters, or other mechanical dewatering facilities shall be sufficient to dewater the sludge produced with the largest unit out of service. Unless other standby facilities are available, adequate storage facilities shall be provided. The storage capacity shall be sufficient to handle at least a three-month sludge production.

14.4.3.1. Auxiliary Facilities for Vacuum Filters - Back-up vacuum pumps and filtrate pumps shall be provided. It is permissible to have an uninstalled back-up vacuum pump or filtrate pump for every three or less vacuum filters, provided that the installed unit can easily be removed and replaced.

14.4.3.2. Ventilation - Facilities shall be provided for ventilation of dewatering area. The exhaust air shall be properly conditioned to avoid odor nuisance.

14.4.3.3. Chemical Handling Enclosures - Lime-mixing facilities of lime dust.

14.4.4. Drainage and Filtrate Disposal - Drainage from beds or filtrate from dewatering units shall be returned to the sewage treatment

process at appropriate points.

14.4.5. Other Dewatering Facilities - If it is proposed to dewater or dispose of sludge by other methods, a detailed description of the process and design data shall accompany the plans.

15.0. Sewage Sludge, Disposal Methods - When sewage sludge disposal methods, such as incineration and landfill, are considered, pertinent requirements of the solid waste regulations shall be followed.

16.0. Land Application of Sewage Effluent

16.1. General - Land application is not to be considered as a treatment process, but only a means of disposing of sewage effluent which has received secondary treatment. For public health reasons, land disposal of effluent that has received primary treatment only shall not be permitted.

16.2. Preliminary Considerations - Land application installations are normally used where the waste contains pollutants which can successfully be removed through distribution to the soil mantle. These pollutants can be removed through organic decomposition in the vegetation-soil complex and by absorptive, physical, and chemical reactions with earth materials. Preliminary considerations of a site for land application should be the compatibility of the waste with the organic and earth materials and the percolation rates and exchange capacity of the soils. The land application of wastewater will eventually recharge the local groundwater; therefore, the quality, direction and rate of movement and local use of the groundwater, present and potential, are prime considerations in evaluating a proposed site.

It is essential to maintain an aerated zone of at least five feet and

preferably more, to provide good vegetation growth conditions and removal of nutrients. It must be realized a groundwater mound will develop below a disposal site after it is in use. The major factors in design of ground disposal fields are topography, soils, geology, hydrology, weather, agriculture practice, adjacent land use and equipment selection and installation.

16.3. Site Plan and Report - The following items shall be considered and shall be included in a site plan and report.

16.3.1. Location Maps - USGS topographic map of the area (7½ minute series where published) showing the location of the total property and proposed land application site. West Virginia State Highway Department County Maps showing location of the total property.

16.3.2. Plan - A topographic map of the entire property at a workable scale showing all buildings, land application area, area of possible expansion, roads, direction of groundwater flow, wells (active and abandoned), public water supplies, groundwater monitoring wells, streams, wooded areas, fences or other barriers, visible geologic formations (sinkholes and rock outdrops), ponds, and all structures, wells and ponds on adjacent property within 2000 feet of the boundaries of proposed disposal area.

16.3.3. Soil Map - A soil map shall be furnished showing soil types within the land application site. This information may be incorporated on the plan.

16.3.4. Report

16.3.4.1. Geology of Site - Including formations, rock types, degree of weathering of bedrock, local bedrock structure, character and thickness

of surficial deposits, solution openings and sinkholes (limestone areas).

16.3.4.2. Hydrology of Site - Depth to seasonal high water table; test well data including chemical and bacterial analysis for groundwater quality and depth of well.

16.3.4.3. Soils at Site - Cation exchange capacity of the soils, soil types and characteristics, detailed chemical analysis of the soils and thickness of the soils.

16.3.4.4. Climatological Data at Site - Including daily rainfall and daily temperature.

16.3.4.5. Agricultural Practices at Site - Including the present and intended soil-crop management practices, kinds of crops to be grown, harvesting frequency and ultimate use of crop.

16.3.4.6. Effluent Characteristics - Detailed chemical analysis of effluent to be disposed.

16.3.4.7. Rate and Frequency of Application - Including all calculations relating to nitrogen, cadmium and heavy metals and calculations for winter storage.

16.3.4.8. Management Practices - Including types of equipment for transport and application; supervision of site; contracts, land easements, land leases, land purchases, monitoring procedures, and emergency procedures in the event of plant or equipment breakdown.

16.4. Design

16.4.1. Effluent Requirements - Secondary treatment will be required (30 mg/l of BOD₅ and 30mg/l of suspended solids). Disinfection will be required with disinfection occurring between the holding pond and disposal

site. Disinfection will be required.

16.4.2. Holding Pond - A minimum 90-day storage shall be provided to store all flow during periods when disposal cannot occur. All storage shall be provided above a fixed water level to prevent complete draining of the pond. A two foot residual water depth is required to prevent growth of vegetation.

16.4.3. Application Rates - The maximum application rates in terms of depth of effluent are: $\frac{1}{4}$ inch per hour; $\frac{1}{2}$ inch per day; two inches per week. It shall be understood that the above are maximum rates and lower application rates may be necessary in some areas due to soil characteristics.

16.4.4. Slopes - Slopes on cultivated fields shall be limited to 4% or less. Slope on sodded fields shall be limited to 8% or less. Forested slopes are limited to 8% for year-round operation but for seasonal operation 14% slopes may be acceptable.

16.4.5. Runoff - The system shall be designed to prevent surface runoff from entering or leaving the project site.

16.4.6. Fencing - The irrigated area will be enclosed with a fence (locked entrance gate) to keep out children and domestic animals. The fence shall be at least six feet high.

16.4.7. Warning Signs - Appropriate signs shall be provided along the fence around the project boundaries to designate the nature of the facility and advise against trespassing.

16.5. Spray Irrigation

16.5.1. Piping to Sprinklers - The piping shall be arranged to allow

the irrigation pattern to be varied easily. For a permanent system, facilities must be provided to allow the pipes to be completely drained to prevent pollution and freezing. The system shall be designed to provide an even distribution over the entire field.

16.5.2. Pump Station - Duplicate pumps will be provided for delivery to the spray field, with the capacity of each pump sized to handle maximum rate of flow, plus an allowance to deplete stored volumes. A metering device will be provided at the pump station, which will show the total flow and rates to the irrigation field.

The top of the disinfection facility and the wet well of the pumping station will be at least as high as the maximum holding pond surface elevation, to prevent flooding these units when the spray irrigation equipment is not in operation.

A control valve between the holding pond and the spray irrigation pump station will be required.

16.5.3. Buffer Zone - Sprinklers must be so located as to give a non-irrigated buffer zone around the irrigated area and design of the buffer zone must consider wind transport of the wastewaters. A fence shall be placed at least 50 feet beyond the normal projected spray area. A minimum of 350 feet from the fence of the enclosed irrigated area to the property lines of adjacent areas or highways is required, unless:

16.5.3.1. Low sprays are provided to reduce wind transport of the effluent.

16.5.3.2. Physical buffers are provided (trees, etc.), alone or in conjunction with low sprays.

16.6. Ridge and Furrow

16.6.1. Slopes - Furrows may be constructed down slope on sites up to 1%. Furrows shall be constructed at right angles to the slope on sites up to 8%.

16.6.2. Construction - Furrows shall be no more than 1,000 feet in length and shall be spaced from 20 to 40 inches apart.

16.7. Overland Flow

16.7.1. Slopes - Slopes shall range from 2 to 8%. Lengths of slopes shall range from 150 to 300 feet.

16.7.2. Construction - Slopes may be flooded or application made by gated pipe or spray.

16.8. Monitoring and Reporting - A minimum of one groundwater monitoring well must be drilled in each dominant direction of groundwater movement, and between the project site and public well(s) or high capacity private wells, with provision for sampling at the surface of the water table and at five feet below the water table at each monitoring site.

The location and construction of the monitoring well(s) must be approved. These may include one or more of the test wells where appropriate. If crops are to be used for animal or human consumption, analysis of the crop will be required at harvest. Frequency of reporting will be determined on a case-by-case basis, by the director, based upon site characteristics.

MINIMUM DESIGN LOADINGS FOR SEWAGE TREATMENT FACILITIES

Facility Description	Unit Sewage Design Flow (gpd)	Unit Five-Day BOD (lbs/day)
Airports		
Each employee	15	.05
Each passenger	5	.02
Assembly Halls		
Per seat	2	.02
Bowling Alleys (No Food Service)		
Per Alley	75	.13
Per Alley with Bar	225	
Churches		
Per Member with Kitchen	5	.02
Per Member without Kitchen	2	.01
Clinics		
Per Staff	20	.03
Per Patient	5	.02
Country Clubs		
Per Member (non-resident)	25	.05
Per Member (resident)	70	.17
Domestic Sewage		
Residences (per resident -a-)		
a. New Collection System	70	.17*
b. Existing/Old Collection System	90	.17*
Summer Cottages, etc., per resident	50	.17
Apartment Houses--one bedroom	140	.34
--two	"210	.51
--three	"280	.60

(NOTE: These factors do not apply to the design of municipal sewage systems.
 Refer to Subsection 1.4 for design loadings for municipal sewage systems.)

Board of Health
 Interpretive Rule 16-1
 Series

Factories (per worker)		
Heavy with cafe and shower	35	.04
Light with cafe	25	.02
Light with shower	25	.02
Light	20	.02
Hospitals		
Each patient (bedside)	300	.34
Each resident staff	100	.17
Each non-resident staff	20	.02
Hotels, Boarding Houses (Exclusive of resturants, bars) per guest		
	50	.15
Industrial Park (Sanitary Waste Only) Per developable acre		
	500	.84
Institutions Per resident		
	70	.17
Laundry (coin operated) Per machine		
	400	1.34
Mine Bath Houses Per worker		
	15	.03
Mobile Homes (b) Per mobile home		
	210	.51
Motels (Exclusive or resturant or bar) Per unit		
	80	.15
Nursing and Rest Homes Per resident		
	150	.26
Per resident staff	70	.17
Offices and Warehouses Per workers, no food service		
	20	.03
Add for food service, per worker	5	.01
Recreation Parks, picnic areas, and beach areas		
	10	.02
Campground, per person	25	.05
Amphitheater, per person	5	.01
Historical site, per person	5	.01
Lodges, per person	70	.17
Park Residences, per person	70	.17
Park Washhouse, per person	30	.05

Board of Health
 Interpretive Rule 16-1
 Series

Resturants		
24 hour service, per seat	50	.17
Ordinary, not 24 hour service per seat	30	.10
Curb service (drive-in) per car space	50	.17
Fast food (single service) per seat	25	.06
Schools		
Elementary, each staff or student	8	.02
High school, each staff or student	10	.03
Boarding school	70	.17
Service stations		
Ordinary, not 24 hour service	500	.80
24 hour service	1000	1.60
Shopping mall per 100 sq.ft.	15	.03
Shopping Center	Based on individual store occupancy	
Swimming Pools		
Per swimmer	5	.01
Add for shower facilities, per swimmer	2	.01
Taverns and Bars, Little or no food service		
Per seat	20	.04
Theatres		
Drive-in, per car space	4	.008
Movie, per seat	2	.004
Travel Trailer Park (-c-)		
No water to site, per person	35	.075
Water to site, per person	50	.10
Disco/Dance Halls, per seat	5	.01
Beauty Parlors/Barber Shops		
Per chair	150	.50
Per operator	20	.02
Dentist		
Per chair	200	.10
Per staff	20	.02

Board of Health
Interpretive Rule 16-1
Series

Doctor

Per patient	5	.01
Per staff	20	.02

- (a) Assume four persons per residence
- (b) Assume 3.0 persons per mobile home
- (c) Assume three persons per travel trailer site

*See Subsections 1.4.3, 1.4.4, 1.4.5.

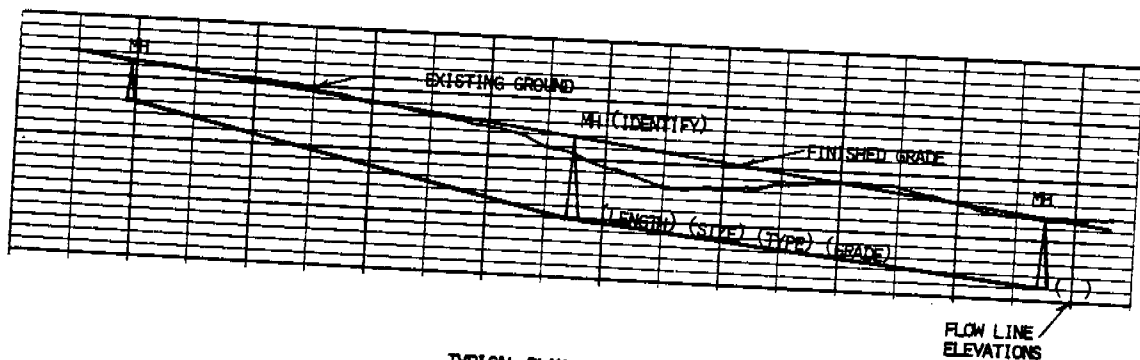
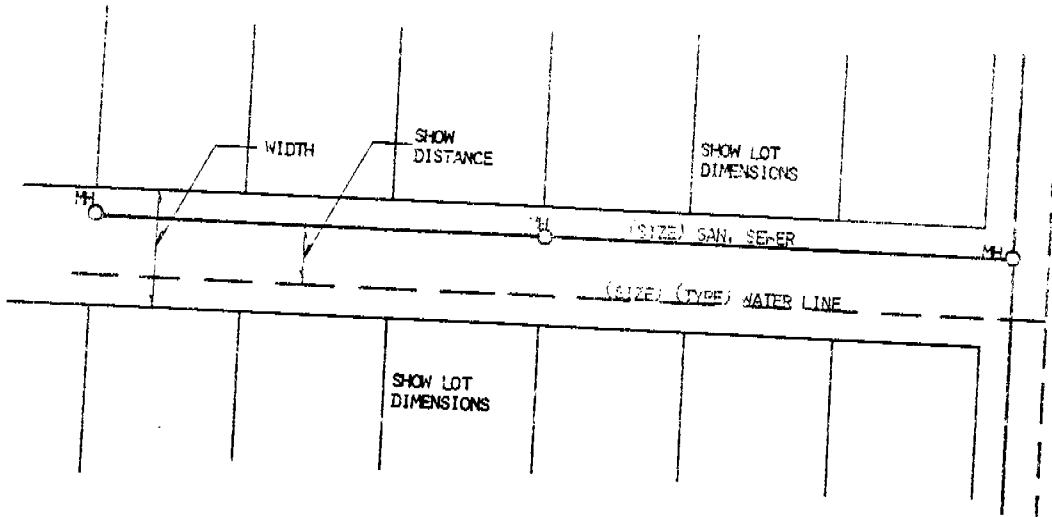

TYPICAL PLAN - PROFILE

STRAIGHT THROUGH MANHOLE

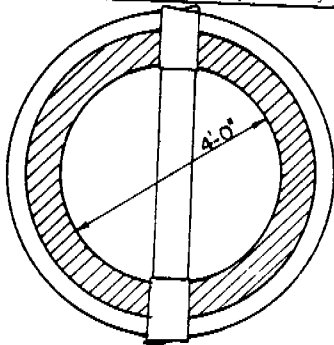
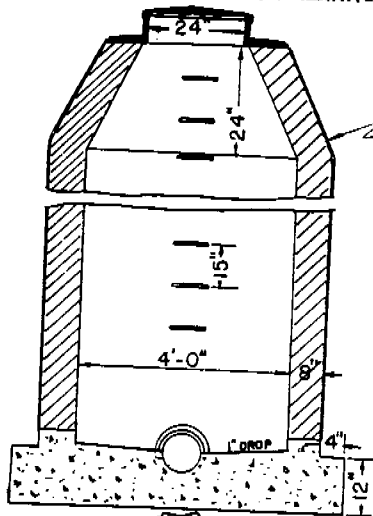

DROP MANHOLE

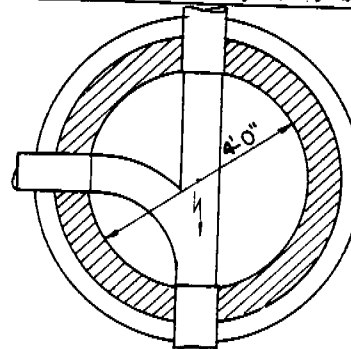
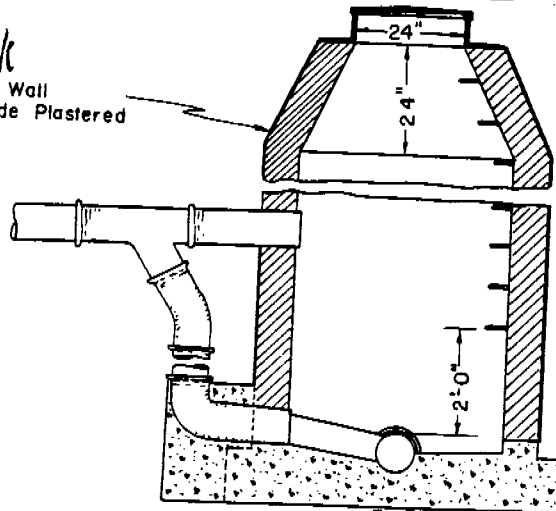

Block
Brick Wall
Outside Plastered

PROVIDE FLOW CHANNELS BY SHAPING THE CONCRETE MANHOLE BOTTOM OR BY USING HALF-SECTIONS OF PIPE. SLOPE MANHOLE BOTTOMS TO FLOW CHANNELS.

TYPICAL DETAIL SEWAGE STABILIZATION POND

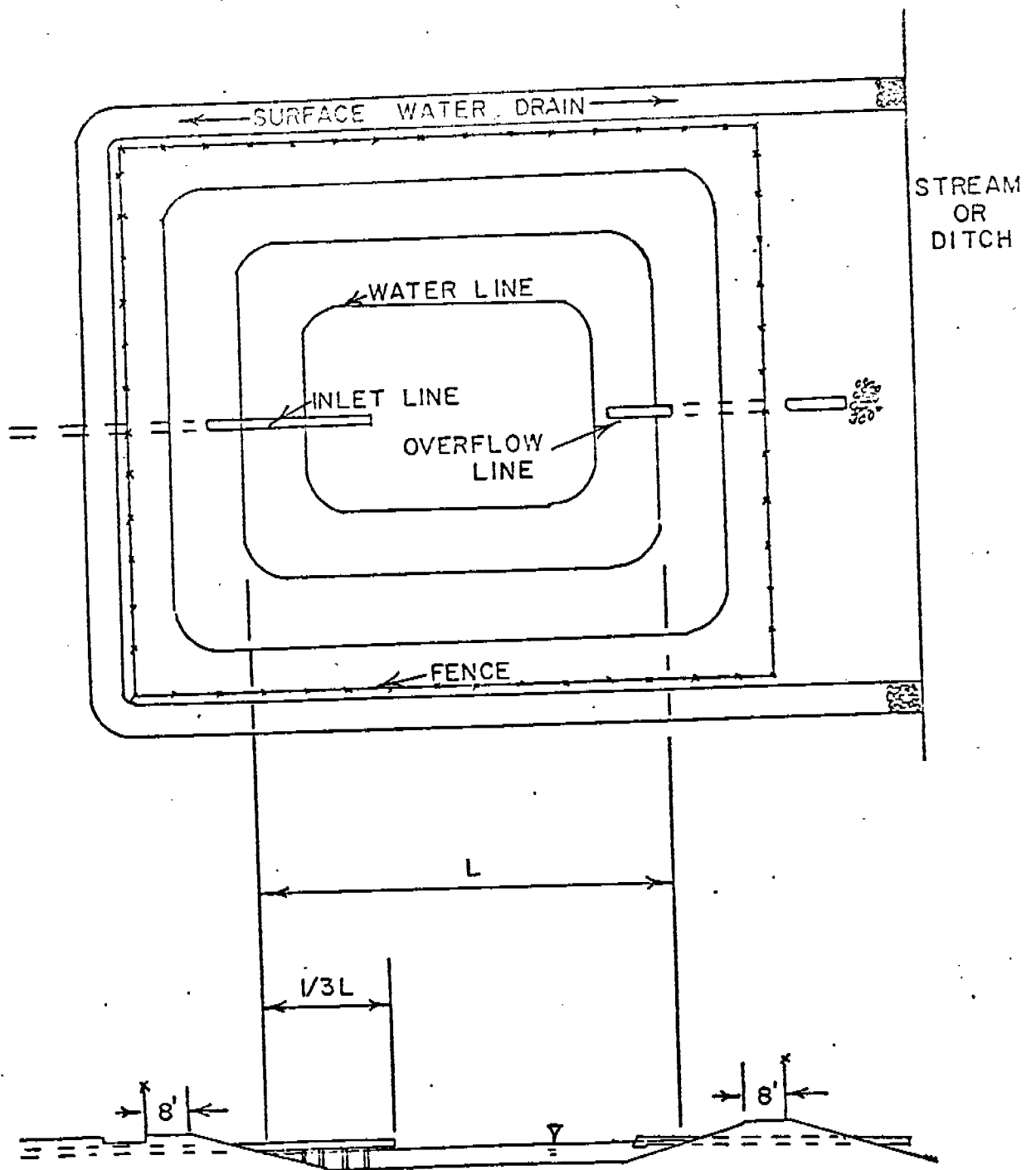

TYPICAL DETAIL POLISHING POND

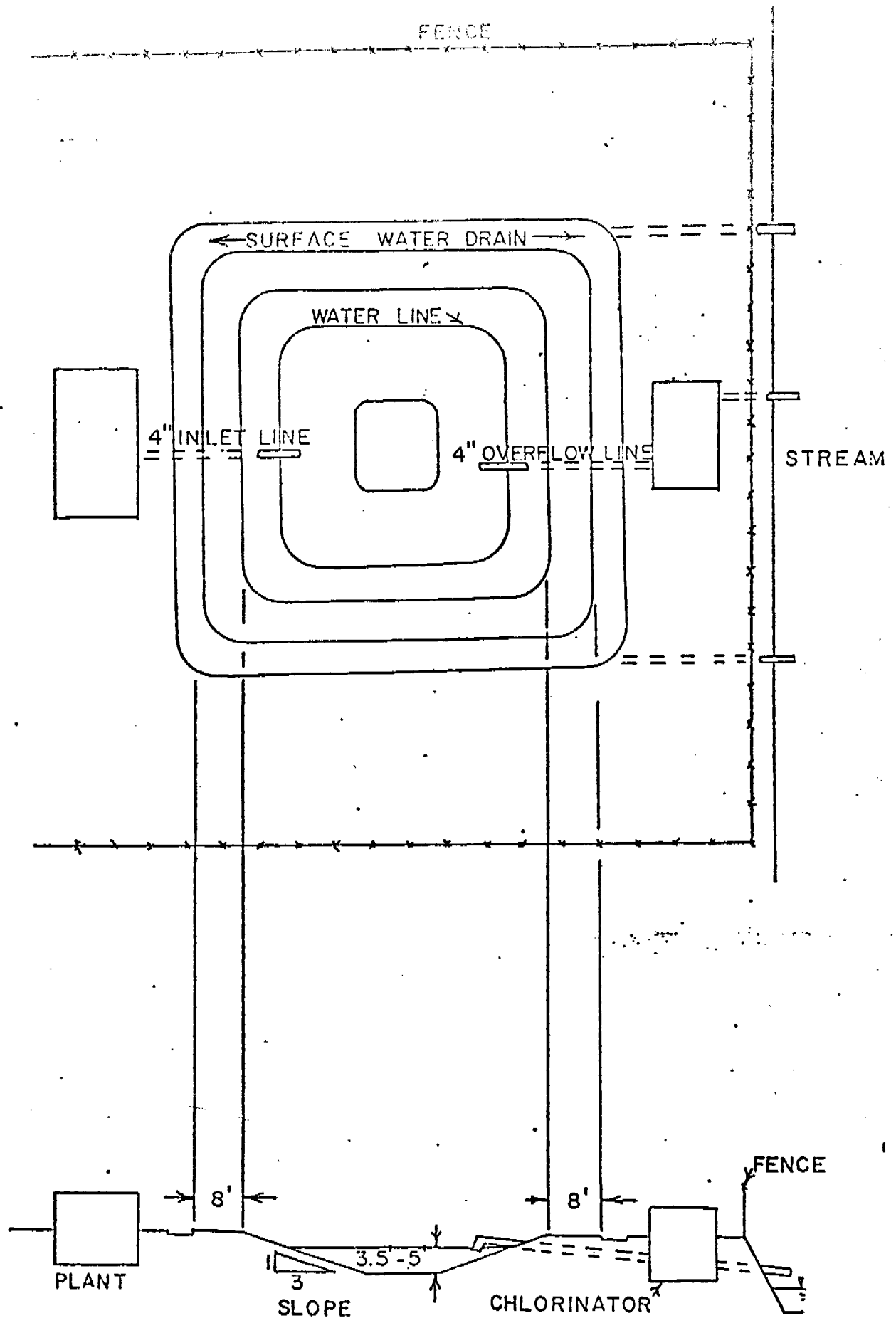

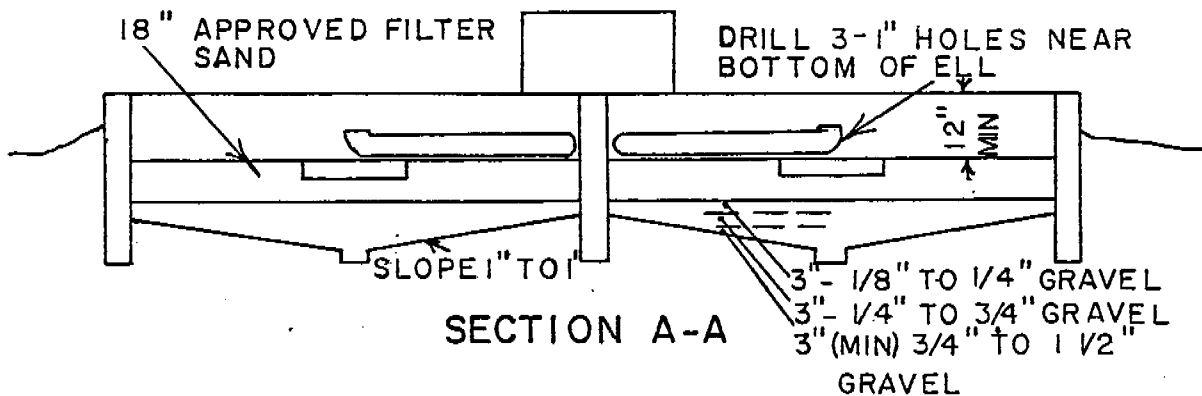
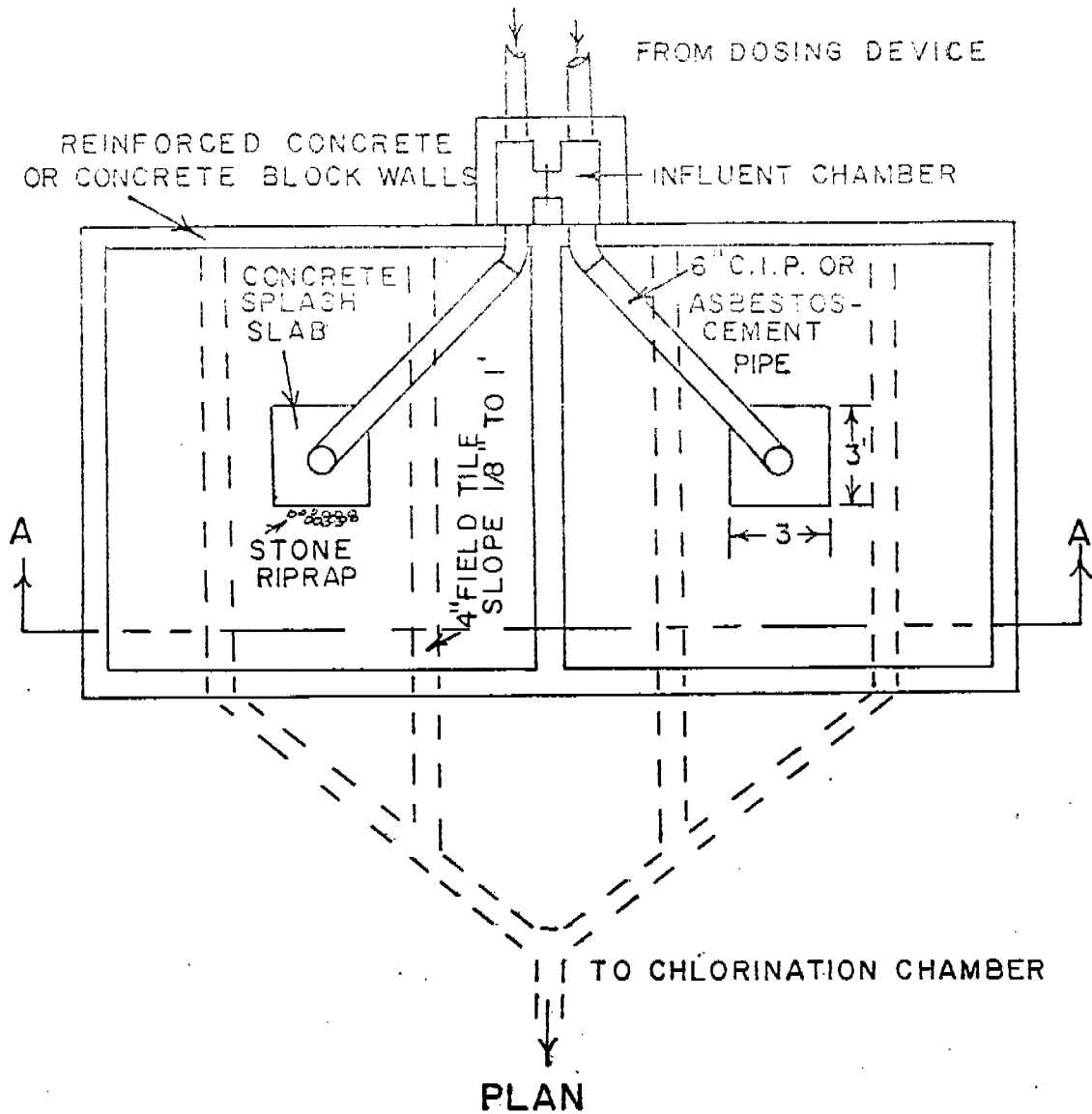

ALTERNATING
SURFACE SAND FILTER
DOSED BY FLOODING

Board of Health
Interpretive Rule 16-1
Series

SECTION 4

Part IV

CUSTOM

SLAUGHTERHOUSES

Part IV
CUSTOM SLAUGHTERHOUSES
INDEX

1.0 General.

2.0 Design

3.0 Treatment.

4.0 Additional Treatment

Custom Slaughterhouses

1.0. GENERAL - These design requirements apply only to custom slaughterhouses (generally less than ten animals slaughtered per week). Prior to applying to the Wastewater Division, an application must be made to the Meat Inspection Division of the West Virginia Department of Agriculture.

2.0. DESIGN - The treatment facility shall be designed on 8.0 lb. BOD₅ per 1,000 lb. live animal weight per day, and 150 gallons per 1,000 lb. live animal weight per day. This figure can only be used if all blood, offal, hair, feathers, paunch manure and fecal matter is removed from the sewage collection and treatment facilities.

2.1. Blood - Blood should be hauled off by a rendering company. If this is not possible, then land disposal may be considered.

2.2. Offal - Offal must be hauled off by a rendering company. Land disposal is not permitted.

2.3. Paunch Manure - Paunch manure and fecal matter can be land disposed.

3.0. TREATMENT - The following types of treatment are recommended:

3.1. Septic Tank - Soil Absorption System (recommended for a maximum of seven animals slaughtered per day operations). As a minimum, multiple septic tanks in series shall be required.

3.2. Aerated Lagoons - (See Part III, Subsection 11).

3.3. Stabilization Ponds - (See Part III, Subsection 11).

3.4. Extended Aeration Sewage Treatment Plants - (See Part III).

3.4.1. Will require flow equalization.

3.4.2. Will require aerated sludge holding tank.

Board of Health
Interpretive Rule 16-1
Series

4.0. ADDITIONAL TREATMENT - Additional treatment may be required depending upon health considerations or Discharge Load Allocation requirements (See Part III).

Board of Health
Interpretive Rule 16-1
Series

SECTION 4

Part V

INDIVIDUAL SEWAGE SYSTEMS

Part V

INDIVIDUAL SEWAGE SYSTEMS

INDEX

Subsection	Page
1.0 General	
2.0 General Site Requirements	
3.0 Septic Tanks	
4.0 Individual Home Aeration Units	
5.0 Standard Soil Absorption Field	
6.0 Absorption Beds	
7.0 Elevated Soil Absorption Systems	
8.0 Dual Soil Absorption Fields	
9.0 Individual Sewage System with Surface Discharge	
10.0 Composting Toilets	
11.0 Incinerating and Chemical Toilets	
12.0 Greywater Disposal Systems	
13.0 Privies	
14.0 Recirculation Toilets	
15.0 Self-Contained Excreta Disposal Systems	
16.0 Holding Tanks	
Appendix A--Effluent Pumping for Individual Sewage Systems	

Board of Health
Interpretive Rule 16-1
Series

Appendix B--Procedures for the Construction of
Soil Absorption Systems in Fill Areas. .

Appendix C--Design Examples and Plans for Mound
Systems.

Board of Health
Interpretive Rule 16-1
Series

1.0. General - These design standards apply to the site requirements, design, construction, and maintenance of individual sewage treatment systems including septic tanks, home aeration units, soil absorption fields, serial distribution fields, absorption beds, mounds, small lagoons, land application systems, composting toilets, grey water systems, holding tanks, privies, recycle systems or any other systems which provide waste treatment and disposal for individual dwellings and commercial establishments.

Application forms and design data sheets may be obtained from the local health department.

1.1. For systems utilizing subsurface or on-site effluent disposal, one (1) copy of the completed application, design data sheet, and plan shall be submitted to the director.

1.2. For systems utilizing other methods of effluent disposal, six (6) copies of the completed application, design data sheet, and plans shall be submitted to the director.

2.0. General Site Requirements

2.1. An individual sewage system shall not be located in a swampy or filled area, or in any area where ponding or flooding is likely to occur, without the prior written approval of the director. Exceptions may be made if the fill area has been constructed in accordance with directions of the director or evidence has been provided to the director that the fill area is suitable and of acceptable composition.

2.2. No part of an individual sewage system shall be located within 10 feet of a building or foundation or property line.

2.3. No part of an individual sewage system shall be located within

10 feet of a water supply line.

2.4. A septic tank, home aeration unit, privy, or other sewage tank shall be located at least 50 feet from a well or groundwater supply.

2.5. Septic tanks, home aeration units, privies, sewage tanks, trench fields, serial distribution systems, beds, mound systems, and other soil absorption systems shall not be located uphill from a water supply well or ground water source unless the system is 200 feet from the source.

2.6. Trench fields, serial distribution systems, beds, mound systems, and other soil absorption systems shall be located to comply with the following distances:

MINIMUM SEPARATION DISTANCES BETWEEN SOIL ABSORPTION
SYSTEMS AND NATURAL AND MANMADE FEATURES

<u>Distance</u>	<u>Feature</u>
10 feet	Foundation drain upslope from disposal area.
20 feet	Stream banks and open drainage features, whether manmade or natural.
20 feet	Manmade cuts in soil and curtain drains.
20 feet	Foundation drains downslope from disposal area.
50 feet	Manmade cuts which intersect rock or shale.
100 feet	Water supply springs and water supply wells.
200 feet	Water supply springs, and water supply wells <u>downslope</u> from the disposal area.

Board of Health
Interpretive Rule 16-1
Series

2.7. Roof drains, foundation drains, sump pumps, surface drains, or similar drains shall not be connected to an individual sewage system.

2.8. The director may require installation of a grease interceptor or grease trap on an individual sewage system serving a dwelling or establishment discharging a large amount of grease.

2.9. No portion of a treatment unit or disposal system shall be located under area to be paved, parking lots, driving surfaces, or any type of structure.

2.10. There shall be a minimum of 3 feet between any portion of a subsurface disposal system and seasonal groundwater or rock, shale or any other impermeable layer.

2.11. A subsurface disposal system shall not be installed in soils where percolation test results show an average percolation time less than 5 minutes per inch except where all surrounding dwellings or establishments are served by a public water supply.

2.12. The evaluation of a site for the installation of an absorption system (trench fields, serial systems, absorption beds, etc.) shall be based upon percolation test results and evaluation of a 6-foot excavation. Percolation tests shall be performed in the following manner:

2.12.1. Location - At least four test holes shall be placed at equal distances over the proposed absorption field site. If the results of the tests are reasonably close, an average test result can be assumed. If the tests show extreme variations, it may be necessary to relocate the field in a more suitable area.

2.12.2. Dig or bore holes from six to eight inches in diameter at the

site where the soil-absorption field is to be installed. The holes shall be dug or bored to the depth of the proposed soil absorption field (24 inch minimum).

2.12.3. Scratch the bottom and sides of the hole with a sharp pointed instrument or wire brush to remove any smeared soil surfaces which interfere with the absorption of water into the soil.

2.12.4. Remove the loose dirt from the bottom of the test holes and place two inches of coarse sand or fine gravel into the holes to prevent sealing.

2.12.5. Place an eight or ten penny nail in the wall of each hole exactly six inches above the level of sand or gravel.

2.12.6. Completely fill the test hole with water to ground level. Keep water in the hole to a depth of at least twelve inches for a minimum period of four hours before beginning the percolation rate measurement.

2.12.7. Percolation Rate Measurement

2.12.7.1. Upon completion of the above, adjust the water depth in the holes to the level of the nail. Accurately determine how many minutes it takes for this six inches of water (all the water) to be absorbed into the soil. This time in minutes divided by 6 gives the rate of fall (or absorption) per inch and is used to calculate the amount of absorption field required.

2.12.7.2. Average the rate of fall for all test holes. (Add the rate of fall for each test hole together and divide by the number of test holes.) This figure is the average rate of fall per inch for the absorption field and is the rate used in calculating the size of the soil absorption field

required. (See Subsection 5.1)

2.12.8. If desired, an alternate method of measurement may be utilized, such as a marked measuring stick and batter board, if approved by the local health department.

2.12.9. Six-Foot Hole - A six-foot hole shall be excavated in the center of the proposed soil absorption system area to evaluate soil depth to rock table and seasonal water table. If slopes at the proposed site exceed 15%, the six-foot hole shall be excavated at the location of the lowest proposed trench of the serial system.

3.0. Septic Tanks

3.1. Septic tank capacities shall be in accordance with the following table:

<u>No. of Bedrooms</u>	<u>Minimum Tank Capacity</u> (gallons)
2 or less	750
3 and 4	1000
Each additional bedroom	250 gallons each

The liquid capacity for tanks serving other than individual residences shall be determined by the following:

Up to 1500 gallons per day - Capacity = 1.5 times daily flow.

1500 gallons per day to 4000 gallons per day -
Capacity = 1000 + .75 time daily flow

4000 gallons per day to 5000 gallons per day -
Capacity = daily flow.

Commercial establishments utilizing garbage grinders shall have tank volume increased 20%.

The volume given is liquid capacity. Liquid capacity will be measured

from the bottom of the tank to the elevation of the invert of the discharge pipe.

3.2. It is recommended that dual compartment tanks or dual tanks be used. If a dual compartment tank or dual tanks are used, the volume ratio of the first compartment or tank to the second compartment or tank shall approximate 2 to 1. In a dual compartment tank, the connection between compartments shall be an elbow with a minimum diameter of 4 inches, placed so that the invert at the partition is approximately 16 inches below the liquid level.

3.3. Septic tanks may be constructed of reinforced concrete, steel, fiber glass, or other watertight and durable material approved by the director. All tanks shall meet the general requirements of section 3.4, regardless of construction material. Septic tank construction shall comply with the following:

3.3.1. Precast Concrete Septic Tanks - Concrete used must consist of at least six (6) bags of cement per yard of concrete mix or equivalent with a minimum compressive strength of four thousand (4000) pounds per square inch. Reinforcement shall be at least 6" x 6" mesh no. 10 welded wire fabric. Aggregate used in the concrete shall be no larger than one (1) inch size. Concrete shall be vibrated to minimize honey-combing. The sidewalls of such tanks shall be at least two and one-half (2½) inches in thickness. The top and bottom shall have a minimum thickness of three (3) inches.

3.3.2. Brick and Block Tanks - Walls may be of 8-inch brick masonry with 1-inch cement plaster inside finish; or 8-inch concrete blocks with 1-inch cement plaster inside finish and cells filled with mortar. Top and

bottom shall meet the requirements for concrete tanks.

3.3.3. Metal Tanks - Tanks shall bear the Underwriters Laboratories, Inc., label or the Kentucky Code Approved designation, or be approved by the director.

3.3.4. Plastic and Fiberglass Tanks - Tanks must be approved by the director.

3.4. General requirements for tanks shall be as follows:

3.4.1. The invert of the inlet opening shall be a minimum of 2 inches above the invert of the outlet opening.

3.4.2. Knockouts must be a minimum of 4 inches in diameter.

3.4.3. The inlet shall be provided with a cast-in-place or inserted baffle or a sanitary tee. The inlet baffle or sanitary tee shall extend to a minimum depth of 6 inches but to no more than 20% of the liquid depth.

3.4.4. The outlet shall be provided with a cast-in-place or inserted baffle or sanitary tee. The effluent baffle shall extend into at least 35% of the liquid depth, but to no more than 40% of the liquid depth.

3.4.5. The top of the inlet and outlet baffles or tees shall extend at least six (6) inches above the flow line.

3.4.6. Minimum liquid depth shall be 30 inches.

3.4.7. There shall be a minimum of 9 inches clearance above the liquid level.

3.4.8. Liquid depth should not exceed 5 feet for tanks less than 3000 gallons and should not exceed 6 feet for larger tanks.

3.4.9. The top of the tank, or either end, above the inlet or outlet, shall be embossed, imprinted, stenciled or other wise marked in an indelible

and legible manner with the manufacturer's name and the liquid capacity.

RECOMMENDED SEPTIC TANK DIMENSIONS				
Size in Gallons G	Inside Length L	Inside Width W	Inside Depth D	Sewage Depth S
750	6'-8"	3'-4"	5'-4"	4'-6"
1000	8'-0"	3'-4"	6'-0"	5'-0"
1250	8'-8"	4'-0"	6'-0"	5'-0"
1500	10'-0"	4'-0"	6'-6"	5'-0"
2000	12'-0"	4'-6"	6'-6"	5'-0"
2500	13'-6"	5'-0"	6'-6"	5'-0"

3.4.10. Access - Adequate access must be provided to each compartment of the tank for inspection and cleaning. Both the inlet and outlet devices shall be accessible; therefore, manholes shall be provided at both inlet and outlet ends of the septic tank.

4.0. Individual Home Aeration Units

4.1. Individual home aeration units shall only be used where additional treatment is provided, such as subsurface absorption or other means of effluent disposal approved by the director. (The director may require ownership, operation, and maintenance of a home aeration unit to be under the control of a public or private utility regulated by the Public Service Commission.)

4.2. Individual home aeration units must bear the NSF seal demonstrating conformance with NSF Standard 40. In order to obtain approval, design specifications and operational data must be submitted for evaluation.

5.0. The Standard Soil Absorption Field

5.1. The design of standard soil absorption systems shall be based upon percolation tests and sized in accordance with the chart below.

SOIL ABSORPTION SYSTEM SIZING
 FOR SINGLE RESIDENCES

<u>Percolation Test Results</u> (Average Time in Minutes Required for Water to Fall One Inch)	<u>Minimum Area of Soil</u> <u>Absorption System (Square</u> <u>Feet per Bedroom)</u>
Less than 5 minutesConsult with local health department
5 - 10 minutes200
11 - 30 minutes250
31 - 45 minutes300
46 - 60 minutes400
over 60 minutesConsult with local health department

SINGLE ABSORPTION SYSTEM SIZING FOR
 ESTABLISHMENTS OTHER THAN SINGLE RESIDENCES

<u>Percolation Test Results</u>	<u>Square Feet Per 1000</u> <u>Gallons Sewage Per Day</u>
Less than 5 minutes.Consult with local health department
5 - 10 minutes	1650
11 - 30 minutes.	2500
31 - 45 minutes.	2950
46 - 60 minutes.	3300
Over 60 minutes.Consult with local health department

5.2. Construction Materials

5.2.1. Pipe for gravity distribution systems shall have a minimum diameter of 4 inches. Smaller size pipe may be utilized for pressure distribution systems.

5.2.2. Pipe utilized in the construction of soil absorption fields

Board of Health
Interpretive Rule 16-1
Series

shall conform to the following standards:

5.2.2.1. Plastic pipe ASTM - F 405 rigid, D 2729, D 2852, D 3350, D 2751, D 2836, D 3033, D 3034, D 3298.

5.2.2.2. Asbestos cement - Class 1500 or 2400.

5.2.3. Perforated pipe utilized in the construction of soil absorption fields shall have a minimum of 2 rows of downward facing holes approximately 90° apart.

5.2.4. Aggregate utilized in the construction of a soil absorption field shall be washed gravel, crushed stone, or slag, $\frac{1}{2}$ to 2 inches in size, with a hardness of 3 on the Moh scale of hardness. Crushed limestone shall be dolomitic. (Field test for hardness—aggregate shall scratch a copper penny without leaving a residue.)

5.2.5. Straw, hay, untreated building paper or newspaper may be utilized to cover the trenches following construction of the absorption fields.

5.3. The construction of the standard soil absorption field with either level or sloping topography shall be in accordance with the following specifications:

5.3.1. The trenches shall be 1 to 3 feet wide with a maximum depth of 36 inches and a minimum depth of 18 inches.

5.3.2. The maximum length of trench shall not exceed 100 feet. If distribution lines of greater than 100 feet are necessary, the solid sewer pipe from the septic tank shall be connected to the center of the distribution line so that the lengths on either side of the connection will be equal and not exceed 100 feet each. Absorption fields dosed by a pump may

Board of Health
Interpretive Rule 16-1
Series

utilize trenches of greater length, but such designs must receive approval from the director.

5.3.3. A minimum of 6 inches of aggregate shall be placed in the bottom of the trench beneath the pipe, and a minimum of 2 inches shall be placed above the pipe.

5.3.4. Trenches shall be constructed level, consistent with the topography and in such a manner so as to minimize the compaction or smearing of the sides and bottoms. Construction of the trenches is not to be done if the soil forms a "wire" instead of breaking apart when rolled between the hands.

5.3.5. The surface of the aggregate shall be covered with either 3 to 4 inches of straw or hay, one layer of untreated building paper or a thickness of at least 4 sheets of newspaper prior to backfilling.

5.3.6. There shall be a minimum of 6 feet of undisturbed earth between the sidewalls of each trench. Additional separation may be required in areas of severe topography and poor soil characteristics to avoid interaction between the trenches.

5.3.7. Soil absorption fields constructed in flat areas shall be designed to provide a closed continuous system or closed circuit design.

5.3.8. The backfilling of the absorption field shall be performed in such a manner to minimize the movement of heavy equipment upon the absorption field. Backfill shall be mounded over the system to allow for settling and to promote run-off from the system. The area where the absorption field has been constructed shall not be graded after backfilling.

5.3.9. The sewer line from the structure to the septic tank shall be

Board of Health
Interpretive Rule 16-1
Series

laid on a grade of not less than 1/8 of an inch per foot (1%).

5.3.10. If the soil absorption field is greater than 1500 square feet in area, a siphon chamber or pump chamber may be required to insure even distribution of effluent.

5.4. The construction of the standard soil absorption field in areas of sloping topography shall be in accordance with the following specifications in addition to the requirements of Subsection 5.3.

5.4.1. Soil absorption fields constructed on sloping ground shall use a serial distribution system.

5.4.2. Soil absorption systems shall not be constructed on ground with a slope in excess of 25%.

5.4.3. The bottom of each trench and its distribution line shall be level.

5.4.4. There should be a minimum of 6 inches of ground cover over the gravel fill in each trench.

5.4.5. The absorption trenches shall follow the approximate ground surface contours so that variation in trench depth will be minimized.

5.4.6. Adjacent trenches shall be connected with a relief line, cross over, or drop box arrangement - in such a manner that each trench is completely filled with septic tank effluent to the full depth of the gravel before effluent flows to succeeding trenches. The construction of the relief line, cross-over, or drop box arrangement shall incorporate the following requirements:

5.4.6.1. The relief line or crossover shall be solid 4-inch sewer line with tight joints and with direct connection to the distribution lines

or a drop box installation.

5.4.6.2. be constructed in any location or manner where they will be subject to damage during or following construction. The location of these relief lines, cross-overs, or drop boxes must be marked prior to backfilling to avoid damage from heavy equipment.

5.4.6.3. The trench for the relief pipe or cross-over shall be no deeper than the top of the gravel of the trenches being connected. The line should rest on undisturbed earth and backfill shall be carefully tamped. Care must be exercised in construction of the relief or cross-over line to insure that an undisturbed block of earth remains between the trenches.

5.4.6.4. The invert of the overflow pipe in the first relief or cross-over line must be at least 4 inches lower than the invert of the septic tank outlet.

5.4.6.5. All other construction features of the disposal construction of a standard absorption field.

6.0. Absorption Beds

6.1. Absorption beds shall only be constructed when topography or space limitations prevent installation of a standard absorption field.

6.2. Absorption beds shall be sized to provide an area 30% greater than that calculated for a standard absorption field to make up for sidewall loss.

6.3. The piping distribution network within the bed shall be installed in such a manner that the pipes are located 18 inches from the sides of the bed with a minimum of 3 feet between pipes and in a continuous or closed circuit design. Construction of the bed shall be in accordance with

the general design and construction requirements of the standard absorption field.

6.4. Maximum depth of a bed shall be 36 inches, minimum depth shall be 18 inches.

7.0. Shallow and Elevated Soil Absorption Systems - Due to the shallowness of many West Virginia soils, a soil absorption system will often have to be shallow or elevated in fill to maintain the minimum distance above the seasonal high water table, rock table, or impermeable soil layer. The construction of a shallow or elevated system is permissible where there is a suitable layer of soil, sufficient room, and the natural slope is not excessive. Shallow and elevated soil absorption systems presently approved for use are: shallow fields, elevated beds, soil absorption mounds, and unique systems designed for specific situations. Due to their complex construction and limited operational history, elevated systems should only be considered when intended to serve existing residences, to correct health hazards, or in other special cases. Shallow fields are similar to the standard absorption field, more easily constructed than elevated systems, and may be considered for new residences.

7.1. Shallow fields and elevated beds may be utilized under conditions where pervious rock table, an impermeable layer of any type, or seasonal water table is within 3½ feet of the ground surface. An elevated bed may be constructed on either level topography or sites of up to approximately 15% slope. Construction of the bed is such that the bottom of the trenches are 3 feet above the rock, any impermeable layer, or seasonal high water table.

Design of shallow fields and elevated beds shall correspond to the following examples dependent upon site conditions:

7.1.1. Shallow Field

7.1.1.1. Shallow fields shall in general be constructed in accordance with the procedures and requirements for standard absorption fields; however, the depth of the trenches in natural ground may vary from 6 to 18 inches. The space between trenches will vary from 6 to 12 feet depending on the trench depth. (See 5-E Diagram)

7.1.1.2. The site shall be filled prior to the construction of the trench system. The site shall be filled in accordance with requirements of Appendix B.

7.1.1.3. Topography of the site may be level, less than 3 percent slope, or up to 15 percent slope if a serial type distribution system is used.

7.1.1.4. The percolation rate for design considerations shall be the slower of the rates recorded for the natural soil at installation depth or for the fill material.

7.2. Soil Absorption Mounds

7.2.1. Soil and Site Requirements

7.2.1.1. Soil and site factors that restrict mound systems are listed in the following tables:

Board of Health
 Interpretive Rule 16-1
 Series

<u>Restricting Factors</u>	<u>Soil Group</u>	
	Slowly Permeable	Permeable Soils with High Water Tables
Percolation rate	60-120 min/in	3-60 min/in
Depth to pervious		
Rock	24 inches	24 inches
Depth to high water		
Tables	24 inches	24 inches

7.2.1.2. Minimum separation distances, as listed in Subsection 2.6, shall be measured from the toe of the fill to the respective feature.

7.2.2. Fill Material

7.2.2.1. Below Absorption Area - Fill material below the absorption area shall be of a medium sand texture. The sand does not have to be washed. (A medium texture sand is defined as 25% or more very coarse, coarse and medium sand and less than 50% fine and very fine sand. The design infiltration rate for medium sand texture is 1.2 gallons per square foot per day.)

7.2.2.2. Above the Absorption Area - The area above the bed or trenches (cap) should be a finer textured soil than the medium texture sand below, to allow plant growth. The soil should have a higher water holding capacity and promote increased runoff due to a more dense nature. A good quality top soil should be placed to a depth of 6 inches over the entire mound.

7.2.3. Mound Design

7.2.3.1. Daily waste water load for design purposes will be 150 gallons per day per bedroom.

7.2.3.2. Absorption Area

A. Sizing - The methods for sizing absorption area vary with the restricting factors. Examples of these methods are provided in Appendix C.

B. Configuration

1. For sites with slowly permeable soils with a seasonally high water table the absorption area shall be in the form of trenches.

2. For sites with permeable soils with a seasonally high water table the absorption area shall be in the form of a bed.

3. For sites with permeable soils over shallow pervious rock the absorption area may be either in the form of a bed or trenches.

4. The mound length runs perpendicular to the slope.

7.2.3.3. Mound Dimensions - Tables listing mound dimensions are provided in Appendix C.

7.2.4. Distribution System - Example of a typical distribution system is shown below. Pipe diameters will vary depending on the length of bed or trenches, as shown in the following table:

Board of Health
 Interpretive Rule 16-1
 Series

Perforation Spacing (inches)	Perforation Diameter (inches)	Pipe Diameter		
		(1 inch)	(1- $\frac{1}{4}$ inches)	(1- $\frac{1}{2}$ inches)
Allowable Pipe Lengths (feet)				
30	3/16	34	52	70
	7/32	30	45	57
	$\frac{1}{4}$	25	38	50
36	3/16	36	60	75
	7/32	33	51	63
	$\frac{1}{4}$	27	42	54

7.2.5. Pumping System

7.2.5.1. Recommended dosing frequency is four times daily. The following table gives recommended dosing quantities for various sized systems. The dosing volume shall be the dosing quantity recommended in the table or at least ten times the lateral pipe volume, whichever is greater.

Recommended Dosing Quantity for Various Sized Homes

Home Size No. Bedrooms	Dosing Quantity Gallons Per Dose
1	50
2	75
3	115
4	150
5	200

Void Volume for Various Diameter Pipes

Diameter inches	Volume gallons per foot
1	.041
1¼	.064
1½	.092
2	.164
3	.368
4	.655
6	1.47

7.2.5.2. Specifications for design of the pump chamber are provided in Appendix A.

8.0. Dual Soil Absorption Fields

8.1. Dual absorption fields may be utilized if percolation rates are between 60 minutes an inch and 90 minutes per inch.

8.2. Area reserved for absorption shall be increased to provide sufficient area for the installation of dual soil absorption fields.

8.3. Construction of the dual absorption fields shall be in accordance with the dosing requirements of the standard soil absorption system, with a junction box or valving arrangement to provide for alternation of the fields. Each of the fields shall be sized in accordance with the percolation test results. Both fields shall be of the maximum sizing required at a 60 minutes per inch rate.

9.0. Individual Sewage Systems with Surface Discharge - Individual systems with surface discharge require a lengthy approval process and, if approved, regular operational supervision and maintenance. For these

reasons they should only be considered for existing residences or establishments when all other means of treatment and disposal have proven ineffective and a real or potential public health hazard exists.

9.1. Individual Sewage System Effluent Disposal Ponds

9.1.1. Effluent from an individual sewage treatment system may be discharged into a stabilization pond system.

9.1.2. Individual sewage system effluent disposal ponds shall be designed on the basis of no more than 34 pounds of 5 day BOD per surface acre. For the purposes of pond sizing, it shall be assumed that there is a 25% reduction in 5 day BOD from a septic tank system and that there is a 70% reduction in 5 day BOD from a home aeration unit. However, an individual sewage system effluent pond shall be a minimum of 1800 square feet in surface area.

9.1.3. Effluent from an individual sewage system effluent disposal pond may be discharged to either an approved land treatment system, or may be discharged to a stream following disinfection, upon approval by the director.

9.1.4. An individual sewage system effluent pond shall be constructed in accordance with Subsection 15.0 of the Design Standards.

9.2. Intermittent Surface Sand Filters

9.2.1. Effluent from an individual sewage treatment system may be discharged to intermittent surface sand filters.

9.2.2. Effluent from a surface sand filter may be discharged to a stream after chlorination in accordance with the regulations and requirements pertaining to surface discharge of waste water.

9.2.3. Intermittent surface sand filters preceded by a septic tank shall be designed on a filtration rate of 5 gallons per day, per square foot. There shall be two filters of design size to provide for alternation of operation.

9.2.4. Intermittent surface sand filters preceded by an individual aerobic treatment system shall be designed on a filtration rate of 10 gallons per day per square foot. There shall be two filters of design size to provide for alternation of operation.

9.2.5. Intermittent surface sand filters serving individual sewage systems shall be provided with an insulated cover to maintain operation during inclement weather.

9.2.6. The intermittent surface sand filter must be dosed by either a pump or sewage siphon.

9.2.7. The design and construction of an intermittent surface sand filter shall be in accordance with the design and specifications provided in figure 5-G.

10.0. Composting Toilets

10.1. Composting toilets may be utilized only in conjunction with an approved grey water treatment and disposal system.

10.2. The design and construction of a composting toilet must meet the requirements of NSF Standard 41.

11.0. Incinerating and Chemical Toilets

11.1. Incinerating and chemical toilets may be utilized only in conjunction with an approved grey water disposal system.

11.2. The design, construction, and application of incinerating or

chemical toilets shall be approved by the director. The use of chemical or incinerating toilets may be approved by the director in emergency situations, temporary usage situations, or for recreational residences, or isolated residences.

12.0. Grey Water Disposal Systems

12.1. Those houses served by a grey water disposal system must have a house sewer of not more than 2 inches in diameter.

12.2. Houses served by grey water disposal systems shall not have garbage disposal units.

12.3. Manufactured grey water disposal systems must be approved by the director.

12.4. Non-commercial grey water disposal systems shall consist of the following:

12.4.1. A soil absorption field designed on the basis of a 30% reduction in water usage, and constructed in accordance with the design requirements for the standard soil absorption fields.

12.4.2. A septic tank sized according to the following:

<u>Number of Bedrooms</u>	<u>Minimum Capacity</u>
2 or less	500
3 - 4	750
5 or more	Add 210 gallons for each additional bedroom

13.0. Privies

13.1. Every privy shall be provided with:

13.1.1. An earthen botton pit with watertight walls, or a water tight

Board of Health
Interpretive Rule 16-1
Series

vault or other watertight receptacle with walls extending at least 6 inches above ground level.

13.1.2. A crowned curb constructed of compacted earth or other suitable material, at least 6 inches thick, extending from the top of the walls of the pit, vault, or receptacle, in all directions over the surface of the ground for a distance of 18 inches.

13.1.3. A riser that is fly tight when not in use.

13.1.4. A vent pipe extending from the pit, vault, or receptacle to a point at least 24 inches above the roof of the of the superstructure or through the wall of the superstructure. The vent shall be screened to prevent the entrance of flies and other insects.

13.2. Privy pits may have an earthen bottom if:

13.2.1. The privy is located in a soil with a tested percolation rate exceeding 60 minutes per inch of fall.

13.2.2. The privy is located below and 100 feet or more from a groundwater supply or individual well, and is so located that any leaching therefrom is disposed of in a manner that does not create a nuisance or insanitary condition.

13.2.3. The pit is 4 feet or less in depth, and it has been determined by the excavation of a 7 foot hole that rock or water table does not exist within 3 feet of the bottom of the pit.

13.3. No privy shall be located within 20 feet of any dwelling or establishment or within 10 feet of any property line.

13.4. The construction and design of the privy superstructure, vault, pit or other type receptacle shall be such as to prevent access to the vault

Board of Health
Interpretive Rule 16-1
Series

or receptacle and the contents thereof, by flies, rats, and wild or domestic animals.

13.5. Privy vaults, pits or receptacles shall have the contents removed as often as necessary to prevent creating a nuisance or unsanitary condition.

13.6. An approved grey water disposal system shall be installed to serve those residences with indoor plumbing or running water for sinks and showers. For those residences without indoor plumbing, a shallow leach trench or pit may be installed for disposal of grey water.

14.0. Recirculating Toilets

14.1. Recirculating toilets and the piping for such toilets shall be separated from and not connected to the potable water system of any residence or other structure under any circumstances. Color coded pipe shall be used to facilitate inspection and maintenance of such installations.

14.2. Recirculating toilets shall:

14.2.1. Be installed and operated in accordance with the manufacturer's instructions.

14.2.2. Be approved by the Director before installation.

15.0. Self-contained Excreta Disposal Systems

15.1. Self-contained excreta disposal systems shall be designed so as to prevent flies, rats, and wild or domestic animals from having access to the contents thereof.

15.2. All fixtures, tanks, or receptacles shall be constructed of impervious, easily cleanable material.

Board of Health
Interpretive Rule 16-1
Series

15.3. Tanks and receptacles shall:

15.3.1. Be watertight and vented to the outside air.

15.3.2. Be constantly supplied with sufficient amounts of an approved chemical agent to process and deodorize the contents thereof.

15.3.3. Have the contents removed and the tank or receptacle thoroughly cleaned as often as necessary to prevent creating a nuisance, or an unsanitary condition.

16.0. Holding Tanks

16.1. Holding tanks are considered a temporary means of sewage disposal to be used for periods of time not in excess of six months. Long term use of a holding tank, in excess of six months, must receive prior approval from the director.

16.2. A holding tank must be watertight and constructed of the same materials and by the same procedures as a watertight septic tank. No openings or pipes through which the contents of the tank may be discharged will be permitted.

16.3. The liquid capacity of the holding tank shall be sufficient to contain one week design flow from the facility to be served.

16.4. Holding tanks shall be located in an area readily accessible for pumping under all weather conditions and where accidental spillage during pumping presents the least hazard to public health.

16.5. Holding tanks shall be located in accordance with the distance requirements established for septic tanks in Part V, Subsection 3 of the Design Standards.

16.6. Construction and installation of the holding tank shall provide

Board of Health
Interpretive Rule 16-1
Series

adequate access to the tank for pumping, cleaning, and maintenance through manhole and cleanouts.

16.7. A holding tank installation shall be provided with an audio visual high level alarm to indicate when the tank is full and requires pumping.

16.8. A contract with a licensed sewage tank cleaner for pumping and maintenance of the tank on a regular schedule shall be required.

APPENDIX A:

Effluent Pumping for Individual Sewage Systems:

A. Pumps

1. Types of Pumps--Non-clog submersible centrifugal effluent pumps or progressing cavity positive displacement pumps.
2. Pumps shall be readily removable and replaceable without dewatering the wet well.
3. Pump should be sized to dose a soil absorption system two to four times a day. The recommended dosing cycle is twice a day, however, the dose shall be no more than 75% of the distribution pipe volume for all soil absorption systems utilizing four inch pipe.
4. The pump shall be located six to eight inches off the tank bottom to provide additional volume for sludge settlement.

B. Pump Controls

1. Relays, and electrical plug-ins or sockets shall not be located inside the wet well or access manhole. These devices must be located above-ground in a weatherproof box or in the residence.

Board of Health
Interpretive Rule 16-1
Series

2. A high water alarm shall be placed within the residence.

C. Distribution System

1. Pipe used for the distribution system (force main) shall be PVC SDR 21, PVC SDR 26, or Schedule 40 of 1½" to 2" diameter.
2. All parts of the distribution system (manifold and laterals) shall be sloped slightly toward the inlet to avoid freezing and ponding of water in the system between dosing.
3. Piping shall be installed below the frost line.

D. Wet Well

1. The wet well shall be watertight and constructed of materials that will not corrode.
2. The wet well shall have an access manhole of 24 inches or greater diameter. The manhole shall be installed level with or above the ground surface and the cover secured.
3. A wet well shall be sized to provide adequate volume not only for one day reserve capacity, but also for single dose capacity plus additional capacity to maintain minimum depth for operation.
4. The wet well tank should be set lower than the septic tank to provide usage of maximum capacity of the wet well.

APPENDIX B:

Procedures for the construction of soil absorption systems in fill areas.

- A. Scarify the area, removing all vegetation prior to preparing for filling. Be careful to minimize the amount of soil removed in this step.
- B. Plow the area to be filled using a mold board plow, plowing perpendi-

Board of Health
Interpretive Rule 16-1
Series

cular to the direction of surface slope with plow throwing soil up slope. Plow to the maximum possible depth (7 to 8 inches). Use as large a plow as possible to reduce the number of driven in furrows which result in compaction of the subsoil. (Plow soil only when the moisture content is low to avoid compaction and puddling. If a fragment of soil occurring approximately 9 inches below the surface can be easily rolled into a wire, the soil should not be plowed since the moisture content is too high. If the soil is friable or dry and falls apart when rolling it into a wire, the soil can be plowed.) Once plowing is completed, keep all vehicular traffic off the plowed area. Minimize time lag between plowing and filling. If it rains after plowing is completed, wait until the soil dries out before the start of construction. Immediate filling after plowing is highly preferable.

- C. Suitable fill material shall consist of soil with a natural permeability of less than thirty minutes per inch, and should contain no large coarse fragments or debris.
- D. Place the fill around the edge of the plowed area by dumping it on the plowed area, keeping the wheels of the dump truck off the plowed area. Wheel tracks in the plowed area will lead to compaction and ruts. This will allow the effluent to flow in the ruts, eventually resulting in seepage.
- E. The plowed area shall be filled in 8 to 12 inch lifts, each lift being compacted to not less than 95% of the maximum density (AASHO). Initially, try to keep at least 6 inches of fill under the tracks to

Board of Health
Interpretive Rule 16-1
Series

minimize sealing of the plowed layer.

- F. Place all the fill needed in the plowed area until this area is at the desired elevation.
- G. Using a bucket on the crawler tractor, dig the trenches in the filled area. Trenches should be 12 to 36 inches wide and 12 inches deep.
- H. Using a bucket on the crawler, dump the gravel in the trench, leveling the gravel off to the desired elevation (6 inches above trench bottom).
- I. Lay the distribution pipe in the center of the trenches, taking care to lay it level with holes downward. Using the bucket, dump gravel in the trench, taking care to disturb the pipe as little as possible. Level the gravel at the desired elevation (two inches above the top of the pipe).
- J. Place straw or hay 3 to 4 inches deep (uncompacted) over the top of the trenches.
- K. Place soil on top of the filled area to a depth of 1.5 feet area and to a depth of 1 foot at the outside edge of the filled area. (Do not drive on the tops of the trenches as you will damage the distribution system.) The upper 6 inches of the soil should be a good top soil, equivalent to or of a better grade than the soil used as fill material.
- L. Landscape the filled area by planting grasses on the surface.

DIMENSIONS

A	0.25S
B	6" Min., 0.25 Max.
C	0.25S
E	0.4S
D	See Text Of Design Standards For Recommendations
S	
L	
W	

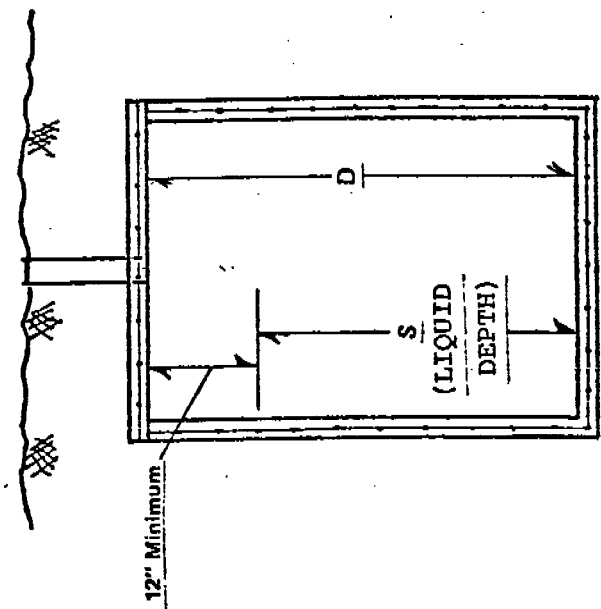
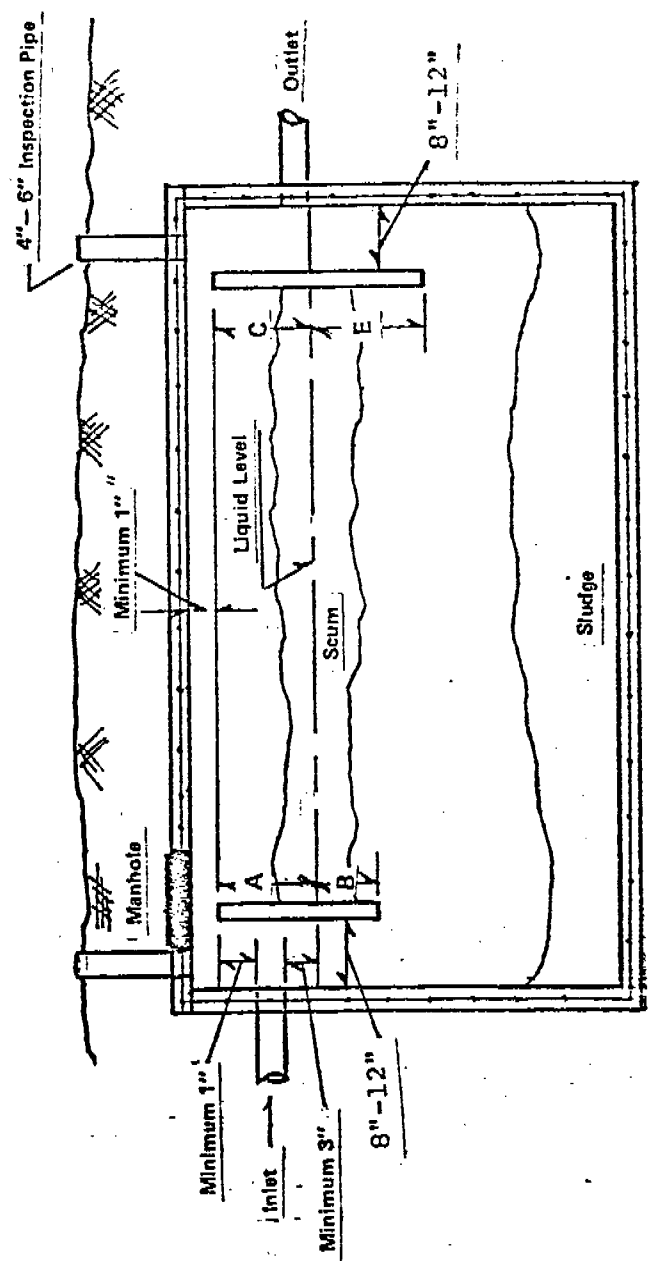
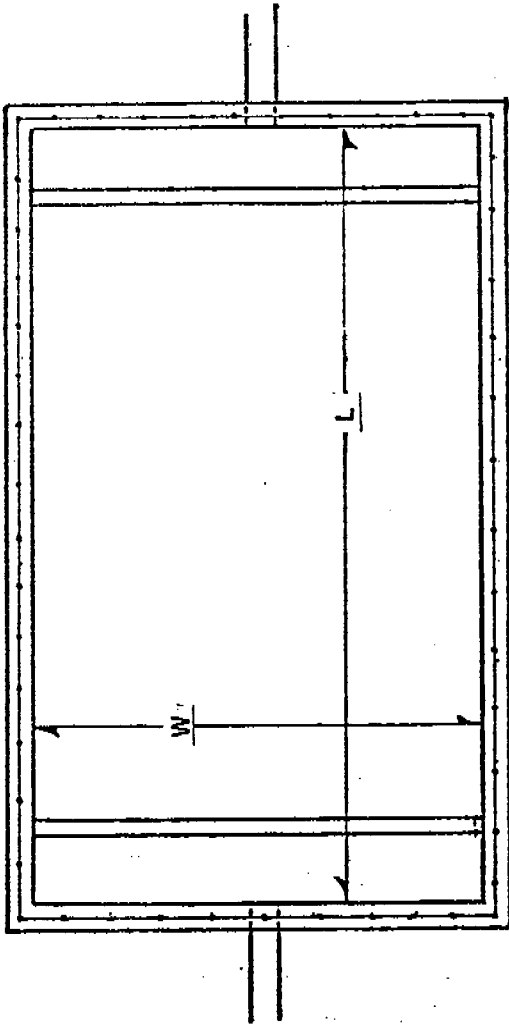

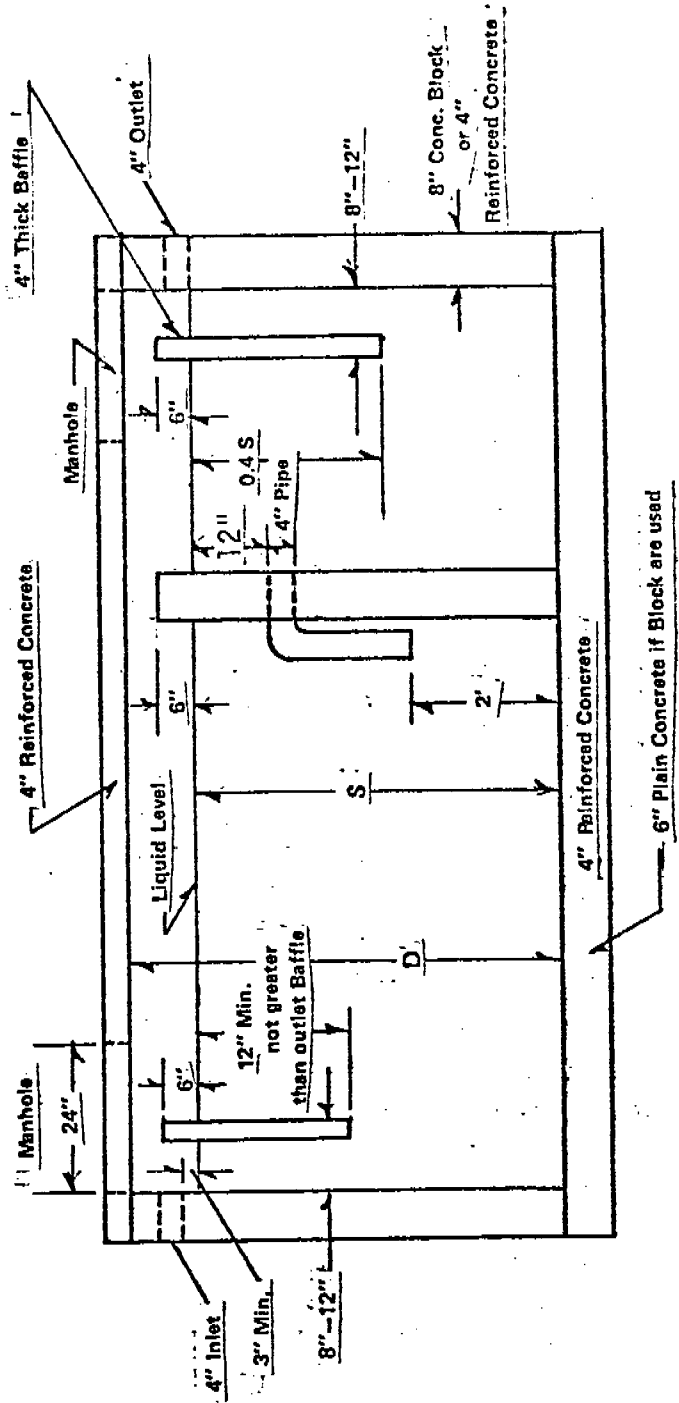
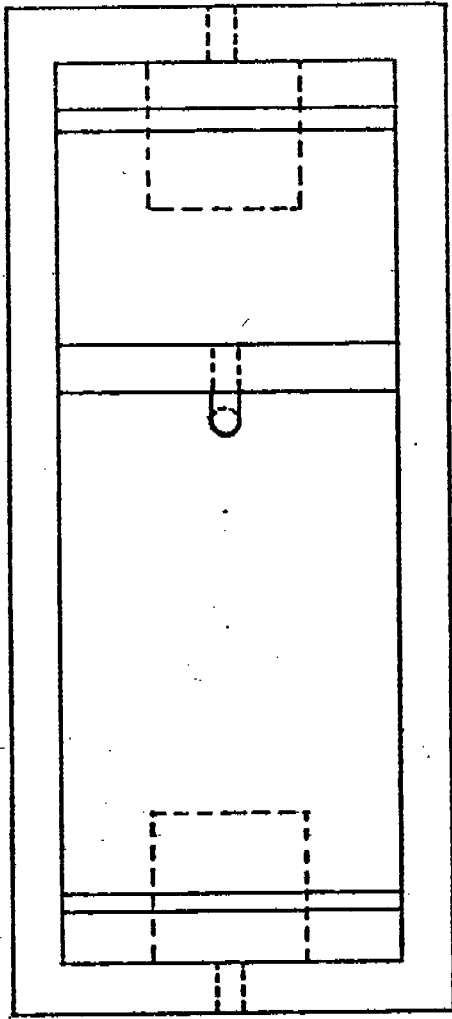

TYPICAL DUAL COMPARTMENT SEPTIC TANK

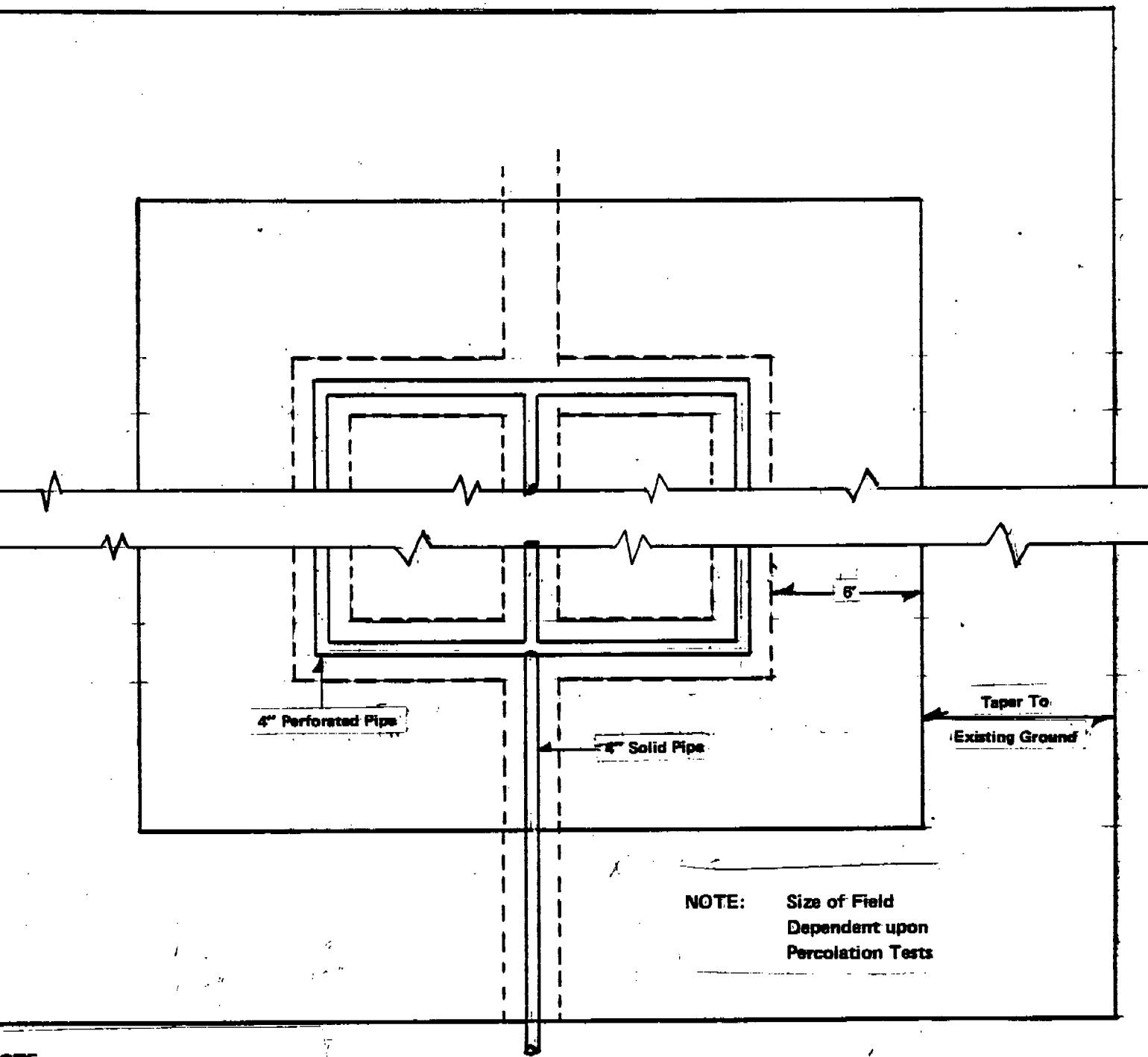

NOTE: Size of Field
Dependent upon
Percolation Tests

NOTE:
Depth to Ground
Water or Rock

5'-0"	Standard Field	B=6'
4'-6"	A = 18"	B=8'
4'-0"	A = 12"	B=10'
3'-6"	A = 6"	B=12'
less than 3'-6"	Do Not Use	

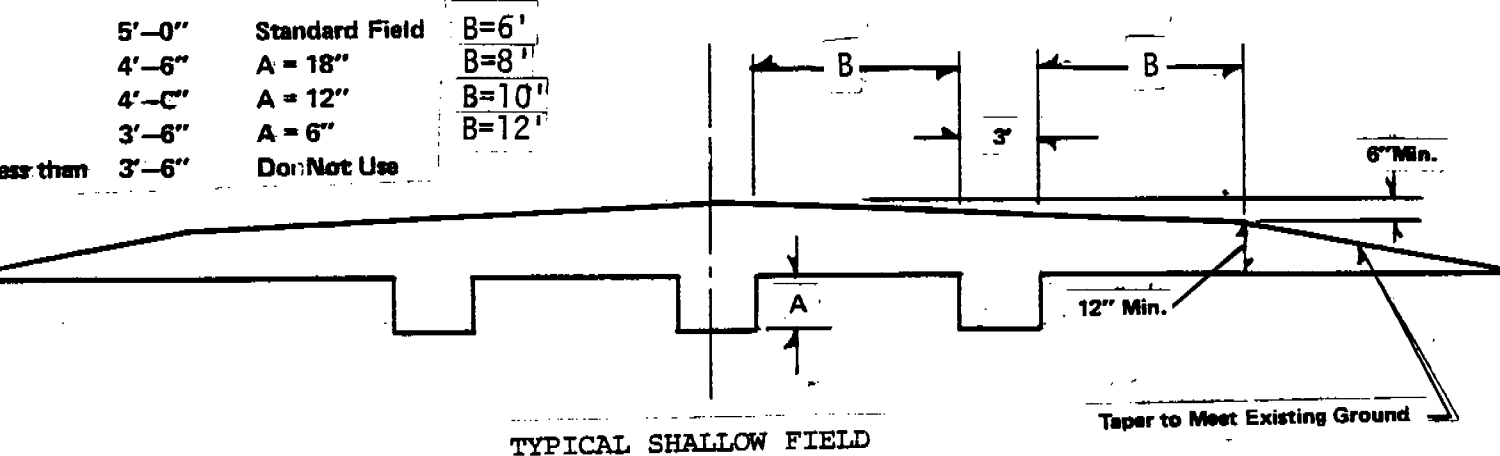

TYPICAL SHALLOW FIELD

Ground Water or Rock 3 1/2 to 5 Feet

NOTES:

1. All pipe 4" in diameter
2. Invert of inlet 1" higher than invert of supply line to downslope Drop Box
3. Trenches may outlet to one side or both sides of Drop Box
4. Drop Boxes may be square, rectangular or cylindrical in shape and of plastic or concrete construction
5. Drop Boxes may be completely buried or placed so that the top of the box is flush with the surface of the ground

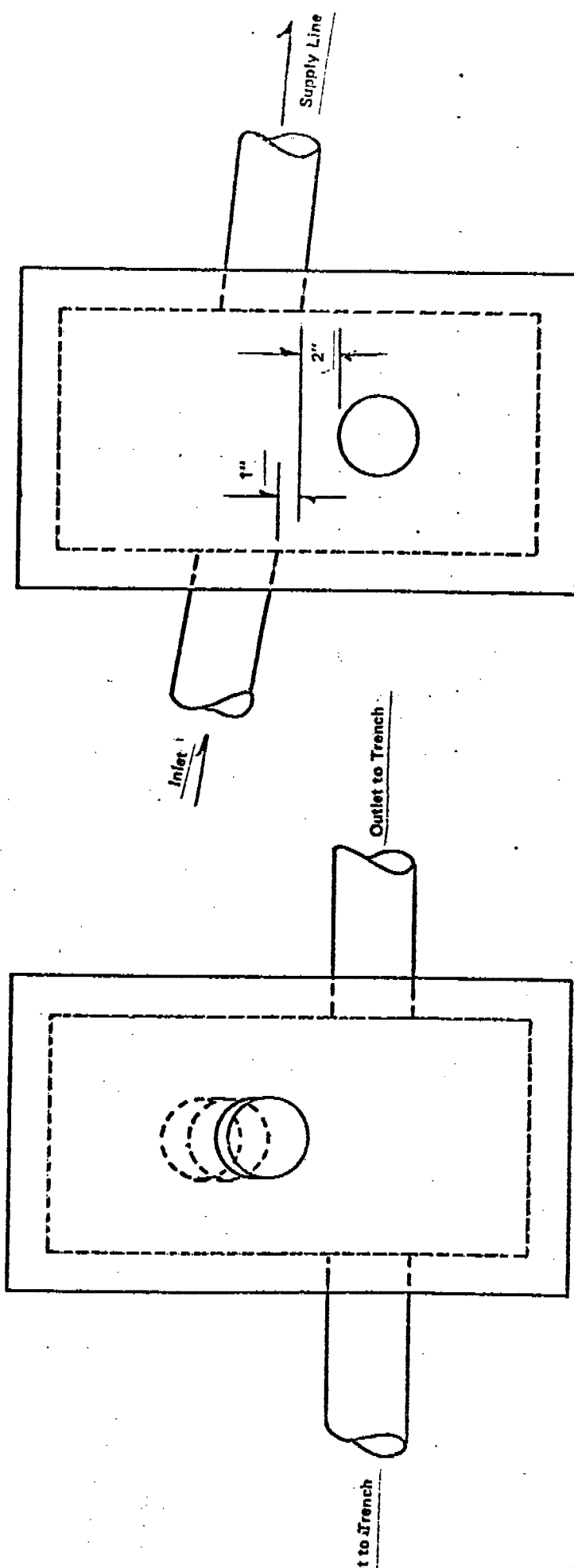
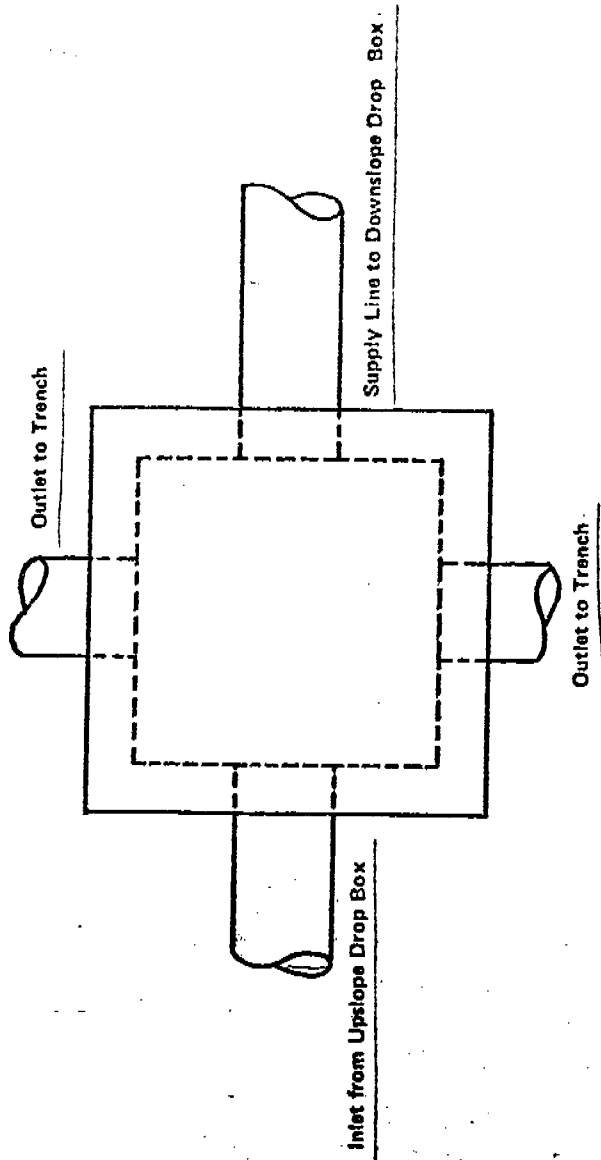

TYPICAL DROP BOX DETAIL

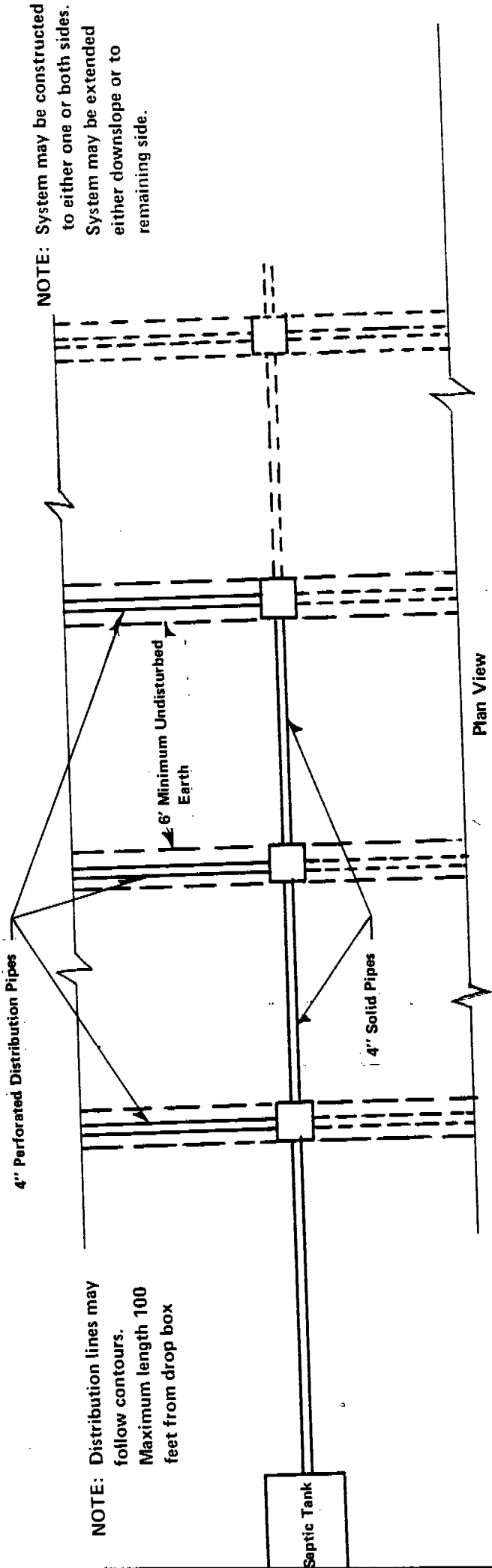
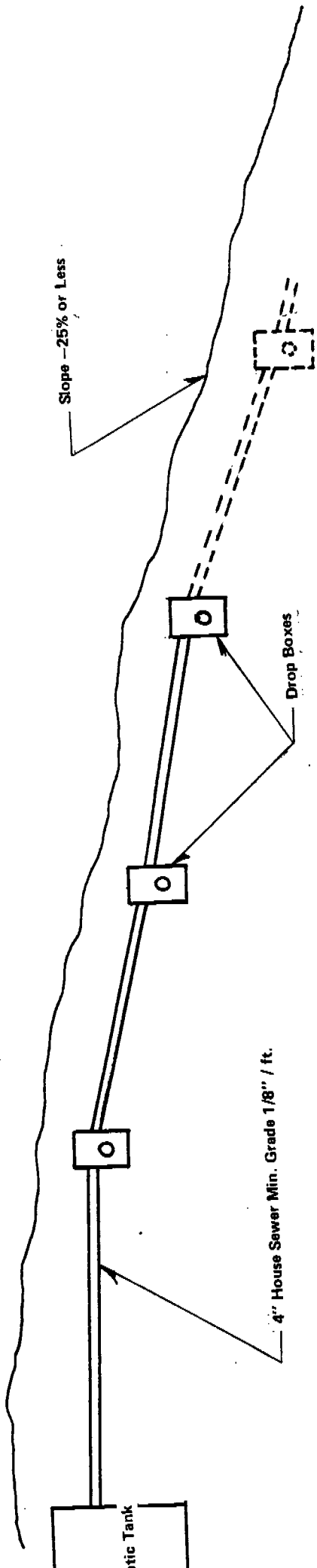

NOTE: System may be constructed to either one or both sides. System may be extended either downslope or to remaining side.

NOTE: Distribution lines may follow contours. Maximum length 100 feet from drop box

TYPICAL DROP BOX INSTALLATION FOR SERIAL DISTRIBUTION SYSTEMS

- NOTES:
1. Septic tank effluent systems require dual filters
 2. Individual home aeration unit effluent systems require single filters
 3. Size of filters based upon 5 gal./ft²/day

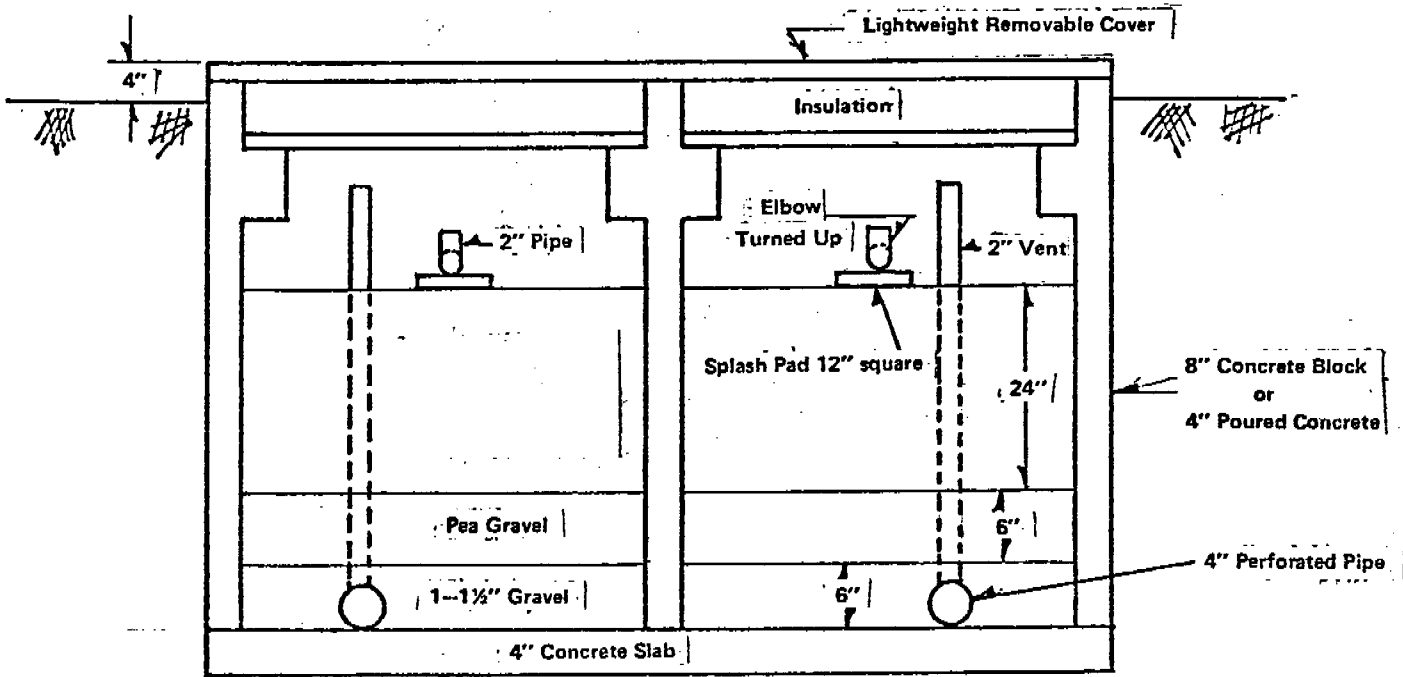
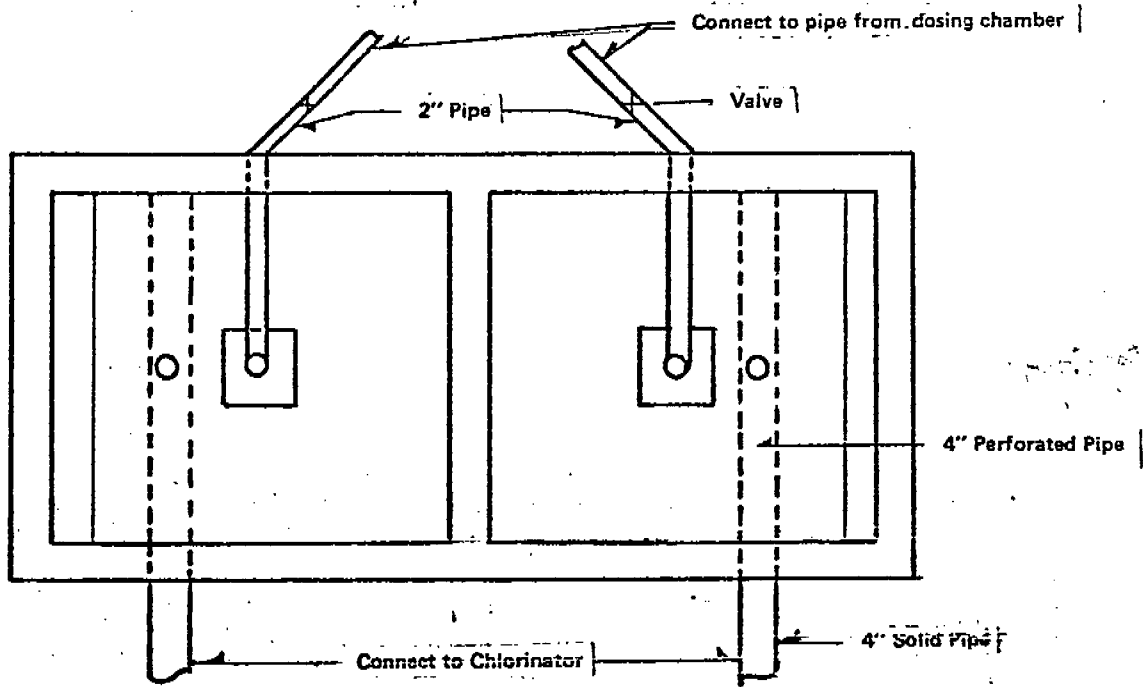

TYPICAL SURFACE SAND FILTERS

NO SCALE

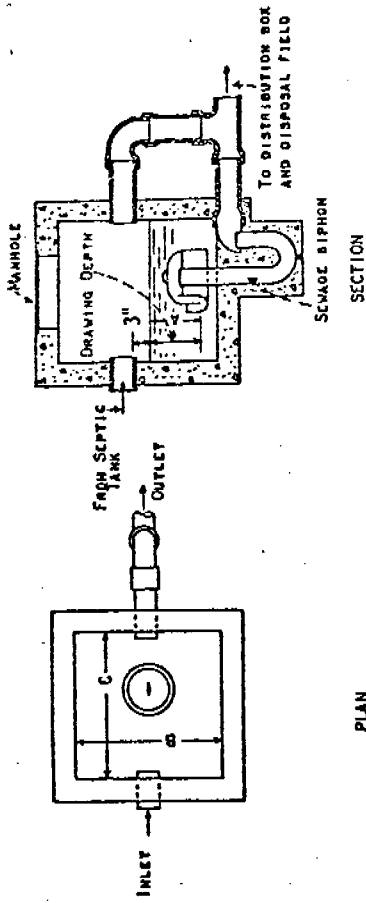

PLAN

SECTION

A DOSING CHAMBER AND SIPHON SHOULD BE INCLUDED ON ALL SEPTIC TANKS GREATER THAN 2500 GALLONS CAPACITY SO THAT LARGE QUANTITIES OF THE LIQUID, AFTER PASSING THROUGH THE TANK, MAY BE QUICKLY AND UNIFORMLY FLUSHED INTO THE ABSORPTION SYSTEM, ALLOWING ALTERNATE REST PERIODS FOR THE TILE DRAINAGE SYSTEM. THE WORKING CAPACITY OF THE DOSING CHAMBER SHOULD BE EQUAL TO ONE-HALF THE VOLUME OF THE TILE DRAINAGE SYSTEM.

DIMENSIONS OF SIPHON CHAMBER FOR SEVERAL DISPOSAL FIELD LAYOUTS

SIPHON SIZE (INCHES)	SIPHON DRAWING DEPTH* (INCHES)	DOSING CHAMBER AREA WIDTH X LENGTH "B" X "C" (SQ. FT.)	LENGTH OF TILE (FEET) IN TILE ADSORPTION TRENCH, STONE FILTER TRENCH, SAND FILTER TRENCH, OR SUBSURFACE STONE FILTER
3	13	8.0	200
3	13	12.0	300
3	13	16.25	400
3	13	20.0	500
4	17	18.5	600
4	17	21.75	700
4	17	24.75	800
4	17	27.5	900
4	17	31.0	1000
5	23	32.0	1200
5	23	36.5	1400
5	23	41.0	1600
5	23	45.5	1800
5	23	50.0	2000
5	23	56.75	2500

* USE DRAWING DEPTH AS GIVEN BY MANUFACTURER FOR YOUR PARTICULAR SIPHON.

TYPICAL DOSING CHAMBER AND SIPHON SEPTIC TANK

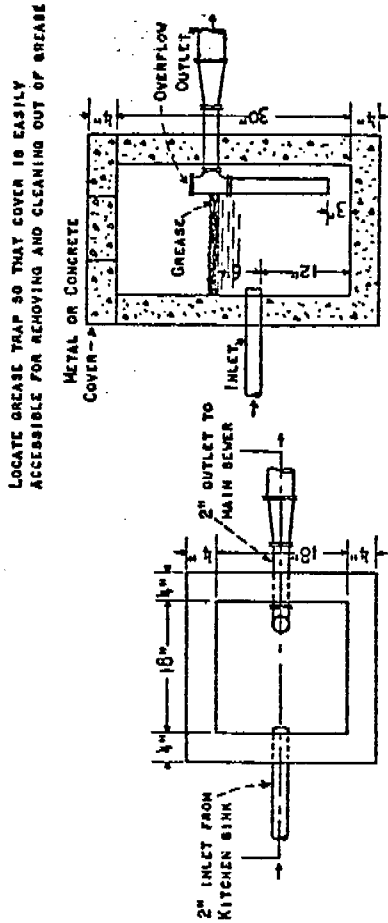

PLAN - COVER REMOVED

SECTION

GREASE TRAP

BAFFLE REQUIRED WITH SIPHON OR WHEN AN OUTLET IS DIRECTLY OPPOSITE THE INLET

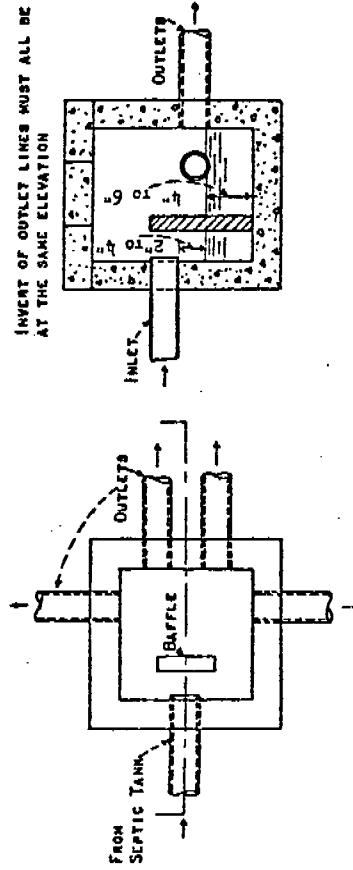

PLAN - COVER REMOVED

SECTION

DISTRIBUTION BOX

TYPICAL GREASE TRAP DISTRIBUTION BOX

Board of Health
Interpretive Rule 16-1
Series

Appendix C

DESIGN AND CONSTRUCTION MANUAL

for

WISCONSIN MOUNDS

- Slowly permeable soils
- Shallow permeable soils over creviced bedrock
- Permeable soils with high water tables

Prepared by

James C. Converse
Agricultural Engineering Department
College of Agricultural and Life Sciences
University of Wisconsin - Madison

September, 1978

Contribution from the Small Scale Waste Management Project (SSWM) University of Wisconsin, College of Agricultural and Life Sciences, College of Engineering and University and the State of Wisconsin. Additional grant funds were received from the Upper Great Lakes and the Environmental Protection Agency (Grant No. R802874-02-0)

TABLE OF CONTENTS

	<u>PAGE</u>
PRINCIPAL OF OPERATION -----	1
SOIL AND SITE REQUIREMENTS -----	4
FILL MATERIAL -----	8
MOUND DESIGN -----	9
Waste Water Load -----	11
Design of Absorption Area -----	11
Mound Dimension -----	11
Basal Area -----	14
Distribution System -----	17
Pumping System -----	17
Electrical and Alarm System -----	24
MOUND CONSTRUCTION TECHNIQUES -----	26
DESIGN EXAMPLES AND PLANS FOR MOUND ON SLOWLY PERMEABLE SOIL -----	33
DESIGN EXAMPLE AND PLANS FOR MOUND ON SHALLOW PERMEABLE SOIL OVER CREVICED BEDROCK -----	51
DESIGN EXAMPLE AND PLANS FOR MOUND ON PERMEABLE SOIL WITH HIGH WATER TABLE -----	65

Preface

The present Wisconsin regulation concerning private domestic sewage treatment and disposal systems, does not allow construction of on-site septic tank disposal systems in soils where the percolation rate is slower than 60 min/in., where the ground water or creviced bedrock is closer than 3 ft beneath the bottom of the system which is less than 5 ft from the ground surface.

The alternate system described in this manual will allow disposal and treatment when the soils below the seepage system has a) a percolation rate between 60-120 min/in. b) where the saturated soil is up to two feet of the ground surface or c) where the creviced or porous bedrock is up to two feet of the ground surface.

This manual replaces the former bulletins commonly known as Package 1, 2 and 3, which were:

- Design and Construction Procedures for Mounds in Slowly Permeable Soils With or Without Seasonably High Water Tables.
- Design and Construction Procedures for Fill Systems in Permeable Soils with Shallow Creviced or Porous Bedrock.
- Design and Construction Procedures for Fill Systems in Permeable Soils with High Water Tables.

The manual is divided into several sections. They are 1) principal of operation, 2) soil site characteristics, 3) design steps and procedures, 4) construction procedures and 5) design examples and example plans for the 3 site situations.

Design and Construction Manual
for
Wisconsin Mounds

Many rural areas in the United States are not suited for on-site disposal of home sewage using the conventional septic tank-soil absorption system because of site limitations such as slowly permeable soils, shallow soils, and high water table soils. A number of alternate systems are being developed to overcome some of these limitations. The septic tank-mound system is one such system which overcomes some of these soil limitations but allows subsurface disposal of the effluent (Fig. 1). A number of adaptations and modifications have been made to the mound system for use under different soil and climate conditions. (Witz 1974; Converse et al. 1975 a b c, 1978; Wooding 1975; Machmeier 1977; Carlile et al. 1977.)

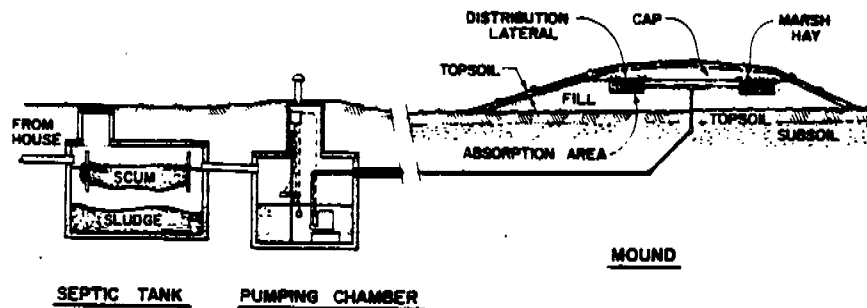

Fig. 1 A cross-section of a septic tank mound system for on-site disposal.

The objective of this manual is to make recommendations of site characteristics, design criteria and construction techniques for a septic tank-mound system which will insure adequate treatment and disposal of household sewage. These recommendations are for on-site disposal of waste water for:

This manual is the result of research performed by the Small Scale Waste Management Project.

1. slowly permeable soils with or without high water tables
2. shallow permeable soils with pervious (creviced or porous) bedrock
3. permeable soils with high water tables

The septic tank-mound system consists of the septic tank, a pumping chamber, and the mound (Fig. 1). The septic tank is sized the same as for the conventional septic tank-soil absorption system. The pump elevates the effluent to the mound and pressurizes the distribution within the mound. A siphon can be used in place of the pump if the mound is located down slope. The mound consists of a fill material, an absorption area, a distribution system, a cap and top soil. The effluent is pumped into the absorption area through the distribution system. It flows through the fill material where it is purified and then it passes into the natural soil. The cap, usually consisting of a topsoil or subsoil, provides frost protection, a barrier to infiltration, retains moisture for vegetation and promotes runoff of precipitation. The topsoil aids in establishing and maintaining a good vegetative cover.

The mound serves several functions, depending upon the type of soil and site situation. For the slowly permeable soils, the primary function is absorption of the effluent into the natural soil. Sufficient purification will result as the effluent moves through the fill and natural soil. The absorption area is raised above the natural soil, using a suitable fill material. This places the absorption area in a more permeable fill material and removes it from the wet slowly permeable subsoil. The advantages are that: a) the effluent enters the more permeable natural topsoil over a larger area where it can move laterally until absorbed by the less permeable subsoil (Fig 2), b) the slimes that develop in the bottom of the absorption area will not clog the fill as readily as they do the less permeable natural soil, c) construction is eliminated in the wetter subsoil where smearing and compaction is often unavoidable, d) the absorption area within the mound is much smaller than it would be if placed in the more slowly permeable subsoil but the mound is probably larger than would be a conventional system if one could be used.

For the permeable soils, the primary function of the mound is to purify the waste before it reaches the ground water or creviced or porous bedrock. By elevating the absorption area with suitable fill, there is sufficient fill and natural soil to provide adequate purification. Fig. 3 shows the typical effluent movement through this system. Most of the flow is downward. Except in the less permeable soils, (as percolation rate approaches 60 min/in.) the flow would move laterally as well as downward and approach the flow regime as shown in Fig. 2.

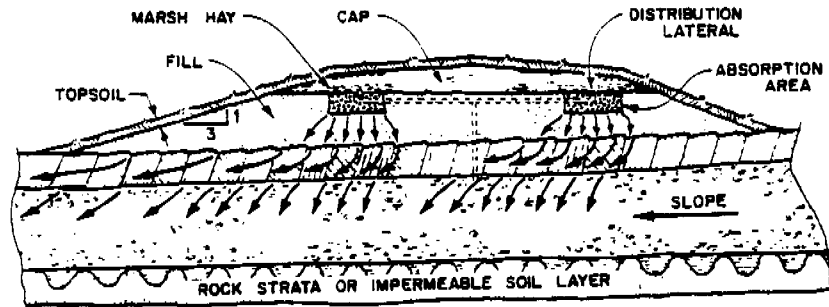

Fig. 2 A cross section of a typical mound system showing the effluent movement in a slowly permeable soil on a sloping site. This mound design utilizes trenches for the absorption area.

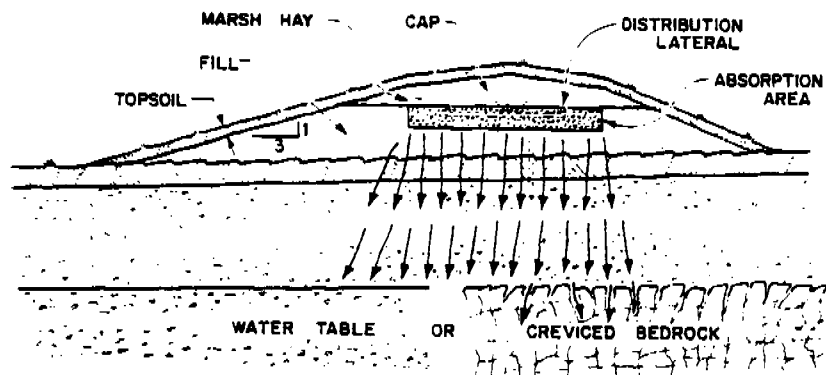

Fig. 3 A cross section of a typical mound system showing the effluent movement in permeable soil, with high water and shallow permeable soil over creviced bedrock. This mound design utilizes beds for the absorption area.

SOIL AND SITE REQUIREMENTS

Table 1 gives the soil and site factors which restrict the installation of the mound for slowly permeable soils, shallow permeable soils over pervious bedrock, and permeable soils with high water tables. The restricting factors are a) percolation rates, b) depth to pervious rock, c) depth to high water table, d) depth to impermeable soil layer or rock strata, e) depth to 50% by volume of rock fragments, f) slope and g) topography factors.

Percolation Rates

Percolation rates are used to determine the suitability of the soil for accepting effluent. For slowly permeable soils, percolation tests are run at a depth of 20-24 in. from the natural surface, except in cases where a more slowly permeable horizon exists above this depth. In that situation, the more slowly permeable horizon is the deciding factor. Mound systems are suitable for these slowly permeable soils if the percolation rate is 60-120 min./in. For shallow permeable soils the percolation test is run at a depth of 12-16 in. below the natural surface. Mounds are suitable for these shallow soils if the percolation rate is 3-60 min./in. For permeable soils with high water tables, the percolation test is run at a depth of 20-24 in. below the natural surface. Mounds are suitable for these permeable soils with high water tables if the percolation is 3-60 min./in.

Depth to Pervious Rock

A minimum of 24 in. of unsaturated natural soil is required beneath the mound. This natural soil provides additional purification capacity and serves as a buffer in protecting the ground water from contamination. It also reduces the amount of fill material needed for the mound, as it serves a part of the unsaturated soil needed for purification.

Depth to High Water Table

High ground water, including perched water tables, should be a minimum of 24 in. beneath the soil surface in order to provide adequate disposal and purification. High water tables can be determined by direct observation or by soil mottling. Occurrence of grey and red soil mottling phenomena can be used to indicate periodic saturation with water. However, lack of mottling does not always mean that seasonally perched water does not occur. For example, Converse, et al. (1975a) reports that some red clays, such as the Hibbing loam in Northern Wisconsin, do not exhibit mottling but perched water is observed for extended periods of time. The presence of mottling may not indicate saturated soil conditions presently but the mottling may have resulted from a saturated soil condition many years previous. Looking at mottling is meaningful but direct observation is preferable if there is any doubt.

TABLE 1. Soil and Site Factors That Restrict Mound Systems

Restricting Factors	Soil Group		
	Slowly Permeable Soils	Permeable Soils With Pervious Bedrock	Permeable Soils With High Water Tables
Percolation rate ^a	60-120 min/in	3-60 min/in	3-60 min/in
Depth to pervious rock	24 in.	24 in.	24 in.
Depth to high water tables	24 in.	24 in.	24 in.
Depth to impermeable soil layer or rock atrata	60 in. ^b	60 in.	60 in. ^b
Depth to 50% by volume rock fragments	24 in.	24 in.	24 in.
Slope	6%	12% ^c	12% ^c

^aPercolation test depth at 24 in., 12 in. and 24 in. for slowly permeable, shallow soils and high water table soils, respectively, unless there is a more restrictive horizon above. If perched water is at 24 in., test depth should be held to 16 in.

^bSee discussion in test.

^cFor percolation rate of 3-29 min/in. max. slope is 12% and for 30-60 min/in., max. slope is 6%.

Depth to Impermeable Soil Layer or Rock Strata

The depth to impermeable soil or rock strata can vary over a range. Wooding (1975) limits the depth to 24 in. while Converse et al. (1975 a,b,c,) recommends 60 in. The optimum distance will vary for a given site. Sufficient area must be available so that the effluent can move away from the mound (Fig. 2). Otherwise, effluent will build up in the mound and cause seepage out the toe of the mound. Climatic factors, soil permeability, slope and system configuration affect this distance. Slowly permeable soils require more area to remove the effluent from the mound than do permeable soils. Frost penetration reduces the effective area for lateral movement, thus in warmer climates depth requirements are not as great as for colder climates. Level sites require shallower depths than do sloping sites, as more area is available for effluent dispersal, since the effluent can move in several directions. Less depth is required for long narrow mounds than is required for more square systems, because the square system concentrates the liquid into a smaller area. Further research is needed to optimize the distance for a given situation. Therefore a judgement decision may be required for a given site.

Depth to 50% By Volume Rock Fragments

Rock fragments do not assist in purification and disposal of effluents. They cause the effluent to be concentrated between the fragments. This may lead to saturated flow and, thus, poorer purification. If the soil contains 50% rock fragments by volume in the upper 24 in. of soil, then there is only half the soil available for purification and disposal of the effluent. Depths greater than 24 in. must be used if the soil beneath the mound contains more than 50% by volume of rock fragments. This is especially so for permeable soils over creviced bedrock and in areas where the high water tables may be potable water sources.

Slopes

Site selection is very important. The crested site is the most desirable because the mound can be situated such that the effluent can move laterally down both slopes. The level site allows lateral flow in all directions, but may present problems in that the water table may rise higher beneath the mound in slowly permeable soils. The most common is the sloping site where all the liquid moves in one direction, away from the mound (Fig. 2). However, proper design can overcome this limitation, especially in the less permeable soils. The mound should be placed upslope and not at the base of the slope. On a site where there is a complex slope, (two directions), the mound should be situated such that the liquid is not concentrated in one area downslope. Upslope runoff should be diverted around the mound.

Mounds require more stringent slope specifications than conventional systems because of their reliance on lateral movement of effluent through the upper soil horizons. Lateral movement becomes more important as soil permeability becomes less. Thus, on more slowly permeable soils the maximum allowable slopes are less. For the more

permeable soils (3-29 min./in.) slope up to 12% slope should function without surface seepage because lateral movement is not so great. For tighter soils (30-120 min./in.) slopes should not exceed 6% slope.

Flood Plains

Construction of mound systems as well as conventional systems is not recommended in flood plains, drainage ways or depressions.

Sites with Trees and Large Boulders

Generally, sites with large trees, numerous smaller trees or large boulders are unsuitable for the mound system because of difficulty in preparing the surface and the reduced infiltration area beneath the mound. As with rock fragments, tree roots, stumps and boulders occupy space, thus reducing the amount of soil for proper purification. If no other site is available, then it is recommended to cut the trees off at ground level, leaving the stumps. A larger mound area may be necessary if too many stumps are involved, so sufficient soil is available to accept the effluent.

Separating Distances or Setbacks

Separating distances should be considered between the toe of the fill and the respective features such as a building, well, slope and stream. In Wisconsin, the separating distances provided in Administrative Code H62.20 shall apply between the toe of the fill and the respective features. When the mound or fill is located upslope from a building or other features on soils with slow percolation rates or slowly permeable subsoil layers, the separating distances should be increased.

Site Preparation

In selecting the site, one must consider the vegetative cover. Trees must be cut level with the ground. Excess vegetation should be cut and removed. The site is then plowed with a mold board plow 7-8 in. deep with the plowing done perpendicular to the slope. It must not be done with the furrow running up and down the slope. Chisel plowing may be used in place of mold board. Roto tilling is not recommended, as it breaks up the soil structure too much. However, roto tilling may be used to incorporate the vegetative cover in unstructured soil such as sand.

The important point is that a rough surface should be left in fine textured soils. The fill will intermingle between the clods, which should improve the infiltration rate into the natural soil (Fig. 4).

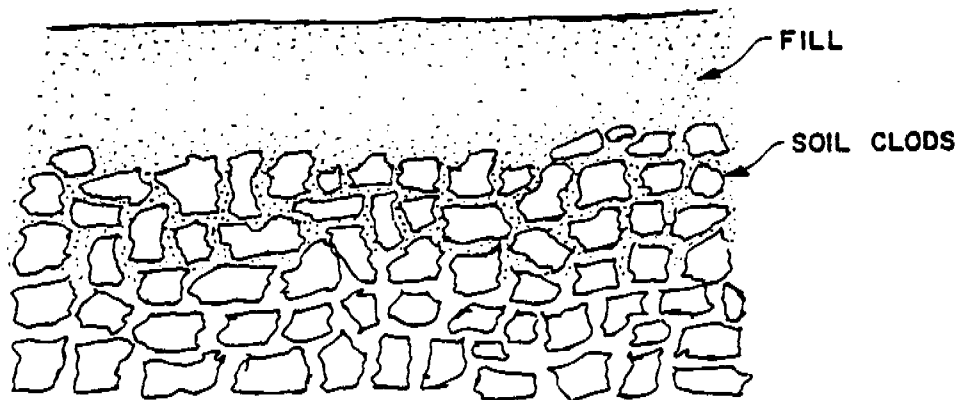

Fig. 4 A schematic view of the plowed natural soil - fill interface showing the intermingling of sand particles with soil clods.

Moisture content of the soil is very important when preparing the surface. If the soil is too wet it will cause excess compaction and smearing where the soil contacts the plow. This will reduce the infiltration capacity of the natural soil. Site preparation should not take place when the soil is too wet. One way of checking moisture content is to take a soil sample from the plow layer (7-8 in.) and roll it between the palms of the hands. If it rolls into a ribbon, it is too wet to prepare. If it crumbles, site preparation can then proceed.

Once the site is plowed, all traffic must be kept off. The fill material can be deposited on the top with a backhoe or pushed on from the side, preferably the upslope side, using a track type tractor, keeping 6 in. of fill beneath the tracks. At no time should ruts be made in the plowed area. The fill should be placed immediately after site preparation to avoid the possibility of precipitation falling on the plowed area.

Traffic on the down slope side of the mound should be minimal to reduce compaction. All work should be performed from the ends and upslope side, especially on fine textured soils. Compaction of the natural soil downslope of the mound will reduce the lateral movement of the effluent and possibly cause surface seepage at the toe of the mound.

FILL MATERIAL

Below Absorption Area

The fill material and its placement are the most costly component of the mound system. Scarcity of good quality fill adds to the cost, due to greater transportation costs. This mound system requires a fill material beneath the absorption area (trenches or bed) of a

medium sand texture. According to soil classification, a medium sand texture is defined as 25% or more very coarse, coarse and medium sand and less than 50% fine and very fine sand. To be a sand, a soil may have between 10-15% silt and clay. When it approaches that consistency, the textural triangle of the Soil Conservation Science should be consulted.

It is not necessary to screen the sand to a given specification. Table 2 is included to give the evaluator an idea of what is acceptable and what is not. The table includes sieve analysis for good, bad and marginal fills. The evaluator may want to sieve a few samples to get a better "feel" for the type of fill required.

The sand does not have to be washed. In fact, some content of fines is desirable. Use of sandy materials with significantly higher contents of silt and clay (for example: sandy loams) is not recommended because of a higher potential for clogging. Fill material is often obtained in sand pits where clayey silt layers may occur naturally between sand deposits. These layers are, of course, unsuitable for fill materials.

The design infiltration rate for medium sand texture is 1.2 gal/ft²/day. This infiltration rate considers that a crusting layer will occur after a period of use.

Above the Absorption Area

The cap (area above the bed or trenches) should be a finer textured soil to allow plant growth due to a higher water holding capacity and increased runoff due to its more dense nature. Sands are not preferred, as they drain rapidly and allow more infiltration of precipitation into the absorption area. Often, excavated soil from the site can be used. Good quality top soil should be placed to a depth of 6 in. over the entire mound to promote good vegetation cover. It is recommended that a fertility test of the material be made and the surface be limed, fertilized and seeded according to the recommendation.

MOUND DESIGN

The design of the mound is based upon the expected daily wastewater volume and the soil characteristics. It must be sized such that it can accept the daily waste water flow without surface seepage and the basal area, which is the natural soil area beneath the mound, must be sufficiently large to conduct the effluent into the underlying top soil. The system must also be designed to avoid encroachment of the water table into the mound.

The design of the mound includes six major steps which are: (1) daily waste water load, (2) design of the absorption area within the mound, (3) dimensioning the mound, (4) checking the basal area requirements (natural soil-fill interface), (5) design of the distribution network, and (6) sizing the pumping system. Each step will be discussed. A design example is included for each type of site toward the end of the manual.

TABLE 2. Examples of Sand Sieve Analyses in Percent of Acceptable and Unacceptable Sands for Mounds in Wisconsin.

Sample No.	USDA Classification							Comments
	Gravel >2mm	Very Coarse Sand 1-2mm	Coarse Sand .5-1mm	Medium Sand .25-.5mm	Fine Sand .1-.25mm	Very Fine Sand .05-.1mm	Silt and Clay <.05mm	
	%	%	%	%	%	%	%	
1	9	6	22	51	11	0	1	good fill
2	5	0	27	51	13	1	1	good fill
3	0	16	16	39	34	4	1	good fill
4	46	13	12	14	6	2	7	unacceptable - too coarse
5	40	15	17	18	7	1	2	unacceptable - too coarse
6	0	0	7	33	55	4	1	unacceptable - too fine
7	2	0	1	4	30	10	53	unacceptable - too fine
8	18	3	8	30	24	4	15	poor to fair - judgement ^a
9	23	15	22	20	10	6	4	poor to fair - judgement ^a

^aSample 8 is a marginal fill because of the many fines. Sample 9 is a marginal fill because it has too much coarse material. Both of these would be judgement decisions. If acceptable fills were close by, these two fills would not be recommended. If acceptable sands were a great distance away, then they could be used.

Daily Waste Water Load

The average daily waste water flow is 45 gal/cap/day (Bennett et al. 1975, Witt et al. 1975). However, this figure should not be used for sizing, as it does not allow for change in the number of people in a home, or for peak flows. It is recommended that the daily flow be estimated at 150 gal/day/bedroom. This assumed two people per bedroom and provides a factor of safety and changes in the number of people in the house.

Design of the Absorption Area

Sizing the absorption area. The size of the absorption area is dependent upon the type of fill material and the daily waste water flow. For a medium sand texture, the recommended design infiltration capacity is 1.2 gal/ft²/day. (See preceding section on fill material). Thus, for a medium sand texture filled mound for a 3 bedroom home, the required absorption area is: 3 bedrooms x 150 gal/day/bedroom ÷ 1.2 gal/ft² = 375 ft.

System configuration. The absorption area within the mound can be in the form of trenches or beds (Fig. 5 & 6). The location of the water table and soil permeability will dictate to some extent if a trench or bed is used. Encroachment of the ground water into the mound of high water table sites must be considered in the design. For slowly permeable sites, the encroachment of the ground water is more severe than on permeable sites. In order to minimize this encroachment in slowly permeable soils, two or three narrow parallel trenches are used instead of a bed. The trenches are sufficiently spaced so the effluent is absorbed in the natural soil before it reaches the downslope trench. For permeable soils, the high water encroachment is not as great, so a narrow rectangular bed can be used. Bed widths should not be greater than 10 ft. wide. For shallow permeable soils over creviced or porous bedrock, either configuration could be used. If a bed is selected, it can be square or rectangular because water table encroachment is usually no problem in creviced or porous bedrock (Bouma et al. 1975).

The trenches and beds must be located perpendicular to the slope so as not to concentrate the effluent into a small area as it moves laterally down slope. Sufficient length must be provided so all the effluent infiltrates into the natural soil before it reaches the toe of the mound. Otherwise surface seepage will result.

The bottom of the absorption area within the bed and trenches must be level and at the same elevation so one area of the bed or one trench is not overloaded.

Mound Dimensions

Mound height. The mound height consists of the fill depth (D & E). The trench or bed depth (F), and the cap and top soil depth (G & H) (Fig. 7 & 9).

The fill depth is dependent upon purification capabilities and desires for a given site. A minimum unsaturated flow depth of 3 ft. of soil is needed for proper purification of the effluent (McCoy and Ziebell

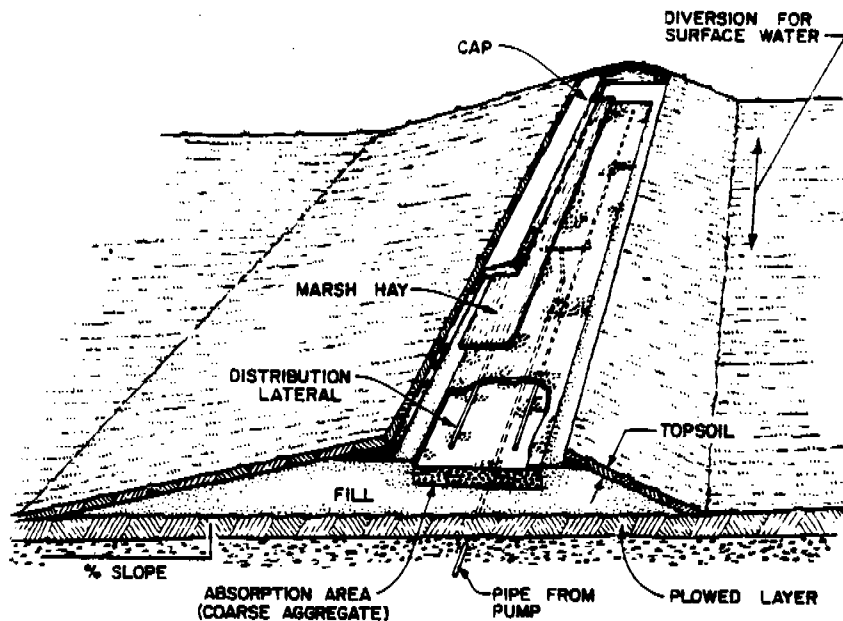

Fig. 5 A mound utilizing a bed as the absorption area.

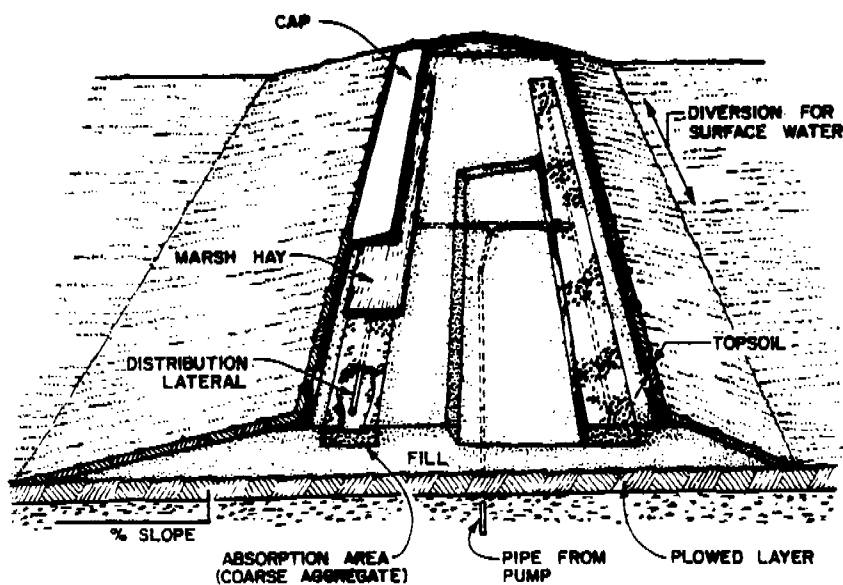

Fig. 6 A mound utilizing two trenches as the absorption area. This system is recommended for slowly permeable soils with high water tables.

When the water table is greater than 2 feet beneath the soil surface, a minimum of 1 foot (D) of fill is necessary. This allows for the bed or trench absorption area within the mound to be sized smaller because of the increased infiltrative capacity of the fill over the natural soil.

For shallow permeable soils over creviced bedrock, the fill depth (D) is a minimum of 2 feet where the natural soil depth is at the minimum of 24 in. This extra depth provides an additional factor of safety as the potential for contamination of a potable ground water is greater on this site than other sites. For deeper soils over creviced bedrock, a minimum depth of 1 ft (D) is necessary, as this allows the absorption area to be designed smaller because of the increased infiltrative capacity of the fill material over the natural soil.

The bed or trench depth (F) should provide some water storage within the aggregate. A minimum of 6 in. of aggregate should be placed beneath the distribution pipe with 2 in. above the pipe. This will give a depth (F) of approximately 9 in. Clean, non-deteriorating 1/2-2 in. stone should be used. Soft limestone should not be used, because it will dissolve or flake off and coat the bottom of the absorption area and, thus, may reduce the infiltration rate.

The cap and top soil (H & G) provides frost protection and promotes runoff. The depth at the center (H) must have a minimum of 1.5 ft. of cap and top soil. For a 3 parallel trench system, this needs to be increased to 2 ft. to give sufficient slope, as the system is wider. At the outer edge of the gravel (G) the cap and top soil needs to be at least 1 ft. deep. This cap can be topsoil or finer textured subsoil. Subsoil will probably promote more runoff but yet retain more water for the vegetative cover. Good quality top soil 6 in. deep must be placed over the entire mound, which provides for good vegetative cover. Vegetation reduces runoff but provides frost protection.

Mound width and length. The length and width of the mound is dependent upon the length and width of the absorption area, mound depth and side slopes of the mound. Side slopes should be no steeper than 3:1 (Fig. 7 & 9). The mound length runs perpendicular to the slope, because the bed or trench length must be perpendicular to the slope so the effluent is not concentrated in one area, but spread out along the slope (Fig. 7, 8, 9 & 10).

The mound length consists of the end slope (K) and the bed or trench length (B). The mound width consists of the upslope width (J), the trench or bed width (A), the spacing between the trenches (C), if trenches are used, and the downslope (I). On sloping sites the downslope width (I) will be greater than on a level site if a 3:1 side slope is maintained. Table 3 gives the slope correction for slopes from zero up to 12% slopes with a 3:1 side slope.

The most critical dimensions of the mound are: mound depth (D & E), bed or trench length (B), bed or trench width (A), the down slope width (I) and spacing from center to center of trenches (C), if trenches are used.

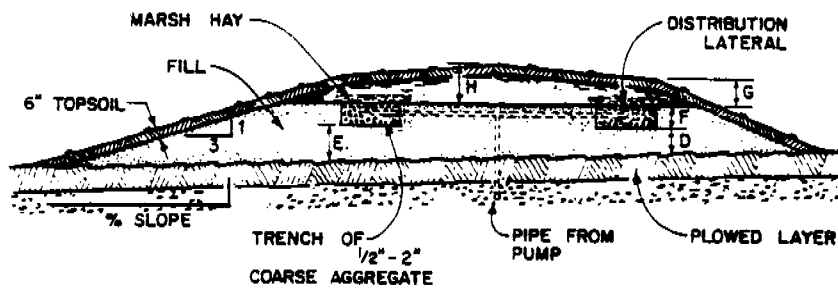

Fig. 7 A detailed cross-section of a mound using trenches for the absorption area. Normally used on slowly permeable soil sites.

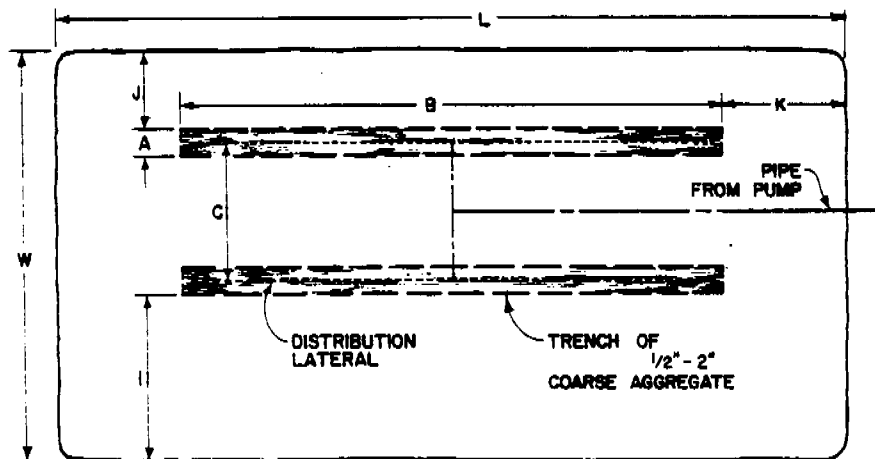

Fig. 8 A detailed plan view of a mound using trenches for the absorption area.

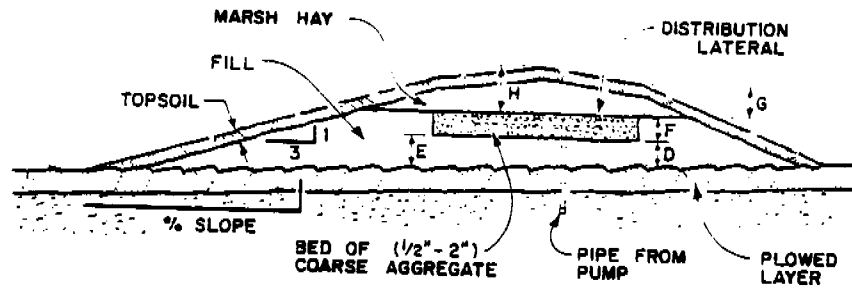

Fig. 9 A detailed cross-section of a mound using a bed for the absorption area. Normally used on shallow permeable soils with creviced bedrock or permeable soils with high water tables.

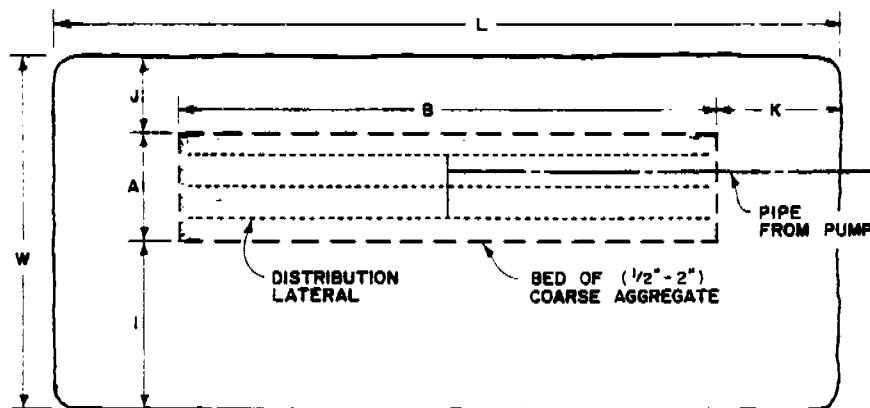

Fig. 10 A detailed plan view of a mound using a bed for the absorption area.

TABLE 3. Downslope and Upslope Width Corrections
for Mounds on Sloping Sites.

Slope %	Downslope (I) Correction Factor	Upslope (J) Correction Factor
0	1.0	1.0
2	1.06	.94
4	1.14	.89
6	1.22	.86
8	1.32	.80
10	1.44	.77
12	1.57	.73

Basal Area

The basal area is the natural soil-fill interface of the mound. Its function is to accept the effluent from the fill, assists the fill in purifying the effluent, and transfer the effluent to the subsoil beneath the mound or laterally to the subsoil outside of the mound.

The basal area required will be dependent upon the soil and site conditions. For level sites, the total basal area beneath the mound can be used. For sloping site the only basal area considered for design is the area beneath and downslope of the bed or trenches. It includes the area enclosed by $B \times (A + C + I)$ for a trench system (Fig. 7 & 8) or $B \times (A + I)$ for a bed system (Fig. 9 & 10). The upslope and end slopes will transmit very little of the effluent. The percolation rate of the natural soil will determine how much area is required. For the following percolation rates, the design loading rates are:

3-29 min/in - 1.2 gal/ft²/day
 30-60 min/in - .74 gal/ft²/day
 60-120 min/in - .24 gal/ft²/day

If sufficient basal area is not available for the given design and site conditions, then additional fill is required to make the mound wider for a level site or the fill is used to extend downslope width (I) on a sloping site until sufficient area is available. For mounds on slowly permeable sites with 3:1 side slopes, it may be necessary to extend this width.

Distribution System

Uniform distribution is necessary within the mound for several reasons. For permeable soils over creviced or porous bedrock, the effluent is spread out over the entire area of the absorption area. This reduces local overloading and provides for unsaturated flow which is necessary for proper purification. In the more slowly permeable soils it uniformly distributes the effluent along the entire length of the bed or trenches. If it were concentrated in one area of the mound, the effluent would move rapidly through the fill and laterally downslope through the natural soil-fill interface. This small area would become overloaded and result in surface seepage out the toe of the mound. The remaining portion of the mound would be unused.

The 4 in. perforated pipe used in the conventional soil absorption system does not uniformly distribute the effluent (Converse 1974; Otis et al. 1978). The distribution system for the mound consists of small diameter laterals and holes (Converse 1974; Converse et al. 1975, Otis et al., 1978). Fig. 11 shows a typical distribution system for a mound. For a trench system, one lateral is sufficient per trench and for a bed system up to 3 laterals are used. Lateral spacing is a maximum of 3 ft. for beds for small mounds only (1-5 bedroom sized systems). Pipe diameters will vary depending on the length of bed or trenches. Table 4 gives the allowable lateral lengths for various size diameter pipes and various hole spacings. For a 30 in. hole spacing and a 1/4 in. diameter hole, maximum lateral length is 25 feet from manifold to end of lateral for 1 in. diameter (Machmeier 1975; Converse 1974). Tee-Tee construction of manifold to laterals is preferred, but cross to cross construction is satisfactory. Manifold diameters of 2 or 3 in. are normally used in mounds for homes. The system must be designed and placed so that the laterals and manifold drain after every dosing. If the mound is downslope of the pumping chamber, then the manifold must be on top of the laterals so the manifold drains or cross to cross construction used.

Pumping System

The components of the pumping system consists of the pumping chamber size, pump size, pump controls and alarm system (Fig. 12). The objective is to design the system so a given quantity of effluent can be dosed at a given frequency. The more frequent dose, the less chance of obtaining saturated flow through the fill, thus, better purification. However, dosing too frequently could lead to faster crusting and poorer distribution of effluent. Dosing frequencies of 4 times daily is recommended. Variations in water use from family to family and from day to day by a given family makes it impossible to maintain a given dosing frequency. This, coupled with the various sizes and shapes of tanks makes it necessary to integrate the components and design flexibility into the system to give the desired quantity per dose.

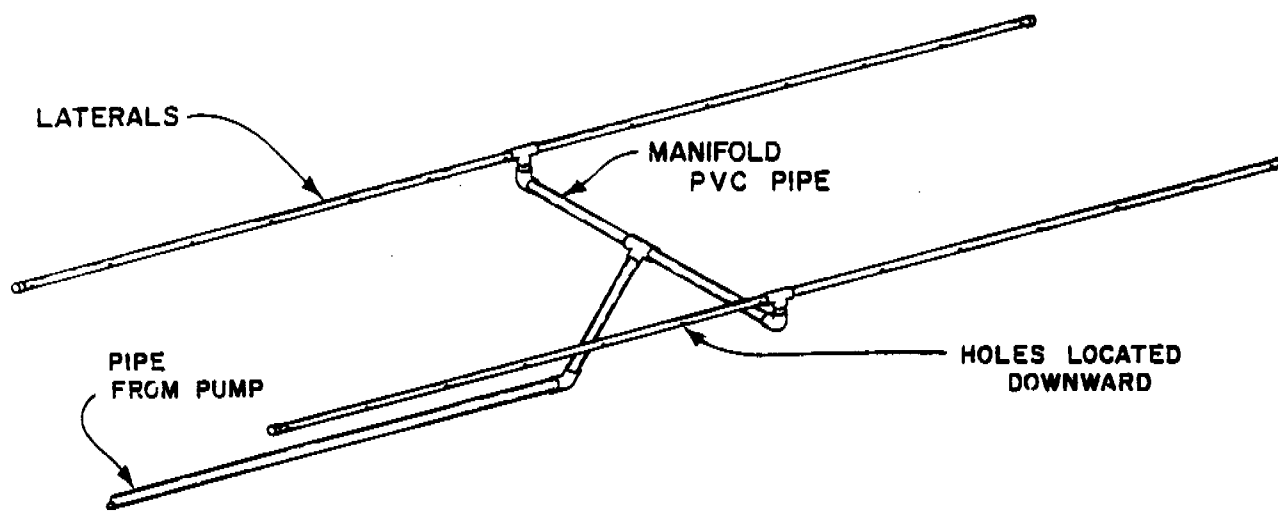

Fig. 11 Typical distribution system for mound with bed or trench absorption system. Design modifications are required if distribution system is down slope of the pumping chamber. Manifold and laterals must drain after each dose.

TABLE 4. Allowable Lateral Lengths (Feet) for Three Pipe Diameters, Three Perforation Sizes, and Two Perforation Spacings (Machmeier 1975)

Perforation spacing (in)	Perforation Diameter (in)	Pipe Diameter		
		(1 in)	(1-1/4 in)	(1-1/2 in)
30	3/16	34	52	70
	7/32	30	45	57
	1/4	25	38	50
36	3/16	36	60	75
	7/32	33	51	63
	1/4	27	42	54

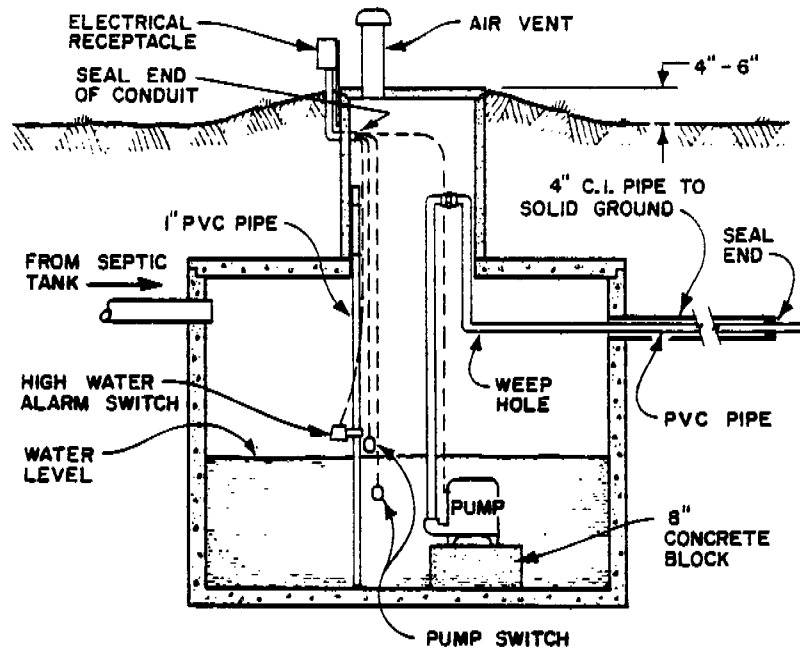

Fig. 12 A detailed cross-section view of a typical pumping chamber

Since both dosing frequency and dosing quantity cannot be achieved due to the water use variation, it is more important to design for the proper quantity per dose. Therefore, the given quantity per dose is obtained by dividing the design load by the desired dosing frequency. For a 3 bedroom sized mound the design load is 450 gal/day and the recommended dosing frequency is 4 times daily which gives a dosing quantity of 115 gal/dose. Table 5 gives the recommended dosing quantities for various sized systems.

The dosing volume should be at least 10 times the lateral pipe volume. This will minimize differences in discharge volumes from first to last orifices in laterals during filling. Table 6 can be used to estimate the void volume for various diameter pipes. If this dose volume is greater than given in Table 5 it should be used, otherwise the value given in Table 5 should be used.

TABLE 5. Recommended Dosing Quantity for Various Sized Homes

Home Size No. Bedrooms	Dosing Quantity* Gal/Dose
1	50
2	75
3	115
4	150
5	200

*Each system needs to be checked to see if this is at least 10 times the lateral void volume.

Pumping Chamber. Figure 12 gives a cross-section of a typical pumping chamber. The volume should be sufficient to provide the desired dosing volume, space for controls, space for setting the pump on a pedestal, and extra volume for a malfunction and flow-back after pump shuts off. Table 7 gives a range of recommended pumping chamber sizes for the various sized systems. Larger tanks may be used, but they may limit the flexibility of adjusting the desired dosing quantity. Smaller tanks may be used, but will limit the storage capacity. Sufficient volume must be available to provide for the dose volume, pump pedestal and controls.

The pumping chamber and septic tank must be watertight so ground water does not infiltrate the tanks as EXCESS WATER INTO THE MOUND SYSTEM CAN CAUSE OVERLOADING AND FAILURE. This is particularly true for high water table soils. Waterproofing consists of adequately sealing all joints and coating the outside of the tanks. Application of 4 mill plastic to the wet asphalt coating will protect the coating when backfilling. Precautions must be taken so pumping chambers do not float out of position due to hydrostatic pressures on the near empty tank. Provisions should be made so surface water does not enter the pumping chamber. This can be achieved by extending the riser pipe 6 in. above the ground surface (Fig. 12). If possible, all electrical controls should be mounted outside the tank. Easy pump disconnect should be used for easy pump removal when pump fails.

TABLE 6. Void Volume for Various Diameter Pipes

Diameter inch	Volume gal/ft length
1	.041
1 1/4	.064
1 1/2	.092
2	.164
3	.368
4	.655
6	1.47

TABLE 7. Recommended Pumping Chamber Sizes for Various Sized Homes

Home Size No. Bedrooms	Minimum Pumping Chamber Size Gallons
1	250-500
2	250-500
3	500-750
4	500-750
5	750-1000

Pump Selection. Proper pump selection is necessary for proper operation of the pressure distribution system. A pump which does not supply sufficient capacity at a sufficient head will not give good effluent distribution (Converse et al. 1975). Pump selection is based on its pump performance curve. The total head is equal to:

- 1) the elevation difference between pump and lateral invert
- 2) friction loss in pipe between pump and distal end of lateral
- 3) recommended head at the distal end of lateral of 2 ft.

Figure 13 can be used to determine head at the supply end of the laterals and the pump size for various sized perforations with 30 in. hole spacing and laterals spaced 3 ft. apart in beds or trenches 3 ft. wide. As can be seen, as pressure at the supply end increases, pump capacity in gpm/ft^2 of absorption area increases. If the pump cannot supply the needed capacity then the pump performance curve will go to equilibrium with the distribution system demand curve by following the selected curve.

As stated earlier the recommended pressure at the distal end of the laterals is 2 ft. which is based on field experience (Converse et al. 1975). Machmeier (1975) recommends a minimum of 6 in. at the supply end of the lateral but small elevation differences along the length of the laterals will greatly affect distribution which would not be the case when using the higher pressures. Using the 2 ft. of pressure at the distal end of the lateral, Fig. 13 shows that the pressure at the supply end of the lateral is 2.5 ft. for the 3 perforation sizes considered. Otis et al. (1978) gives a more detailed procedure for calculating head losses which should be used for larger systems.

Using 2.5 ft. of head at the supply end which gives 2 feet at the distal end, the flow rate for 1/4 in. perforation is 0.14 gpm/ft^2 of absorption area (Fig. 13). For a 3 bedroom sized mound which requires 375 ft. of absorption area, a pump must have the capacity to pump 54 gpm for the total system head. Table 8 gives the necessary pump capacity for two different perforation sizes for various sized systems.

Table 9 is used to determine the friction loss in the pipe between the pump and the inlet to the distribution system. For a given flow rate, length of pipe and pipe diameter, the friction head can be determined.

TABLE 8. Pump Flow for Various Sized Mounds Using a 7/32 in. and 1/4 in. Dia. Perforations for a Pressure of 2.5 ft. at the Supply End of the Lateral. Laterals are Spaced 3 ft. Apart with Perforations Spaced 30 in. Apart. (Based on Curves in Fig. 13).

Home Size No. Bedrooms	Absorption Area For Distribution System ft ²	Pumping Capacity ^a	
		7/32 in. orifice dia. gpm	1/4 in. orifice dia. gpm
1	125	15	20
2	250	28	36
3	375	41	54
4	500	54	70
5	525	68	90

^a pump capacity required for the total pressure head which includes elevation difference, friction loss and desired pressure is lateral.

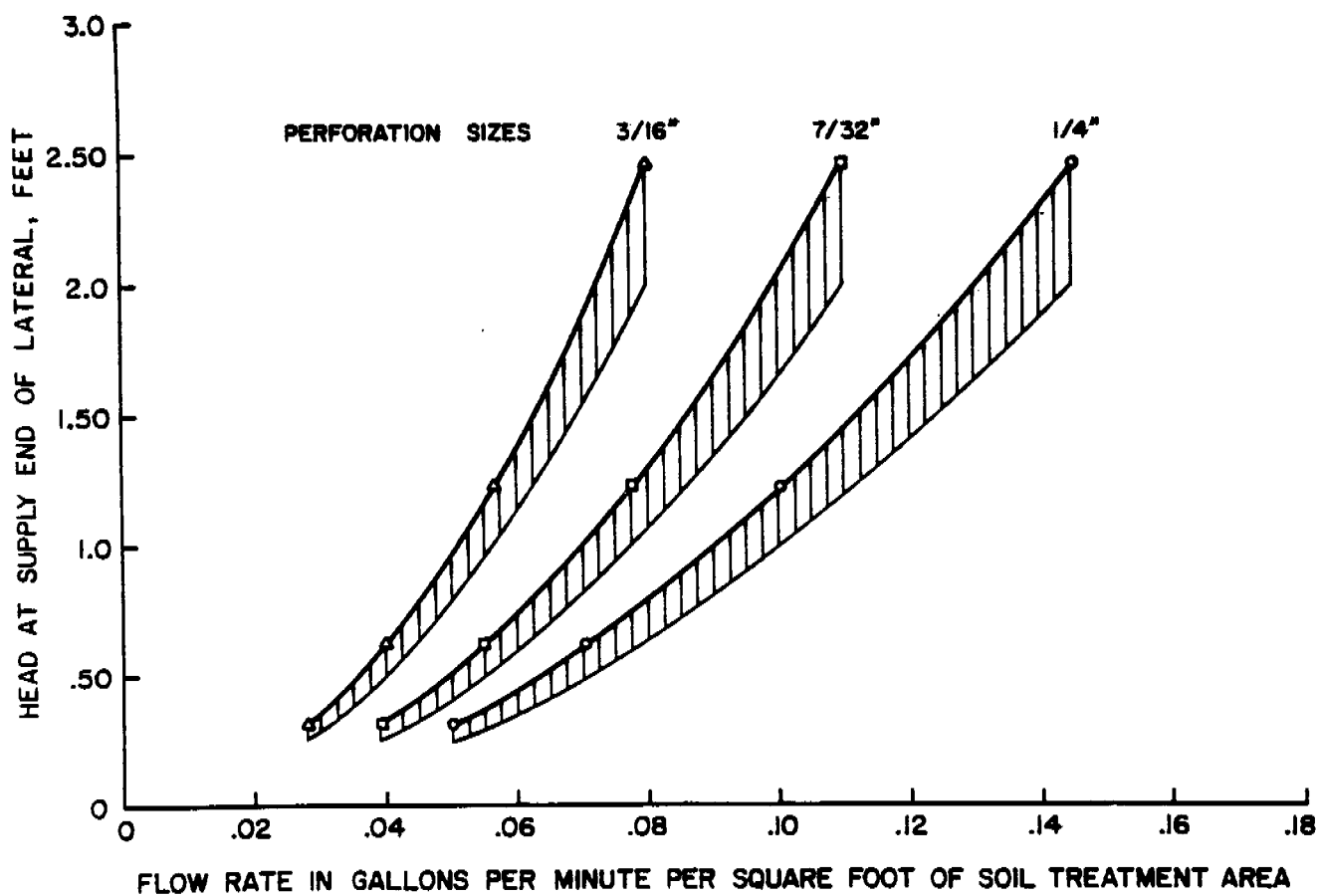

Fig. 13 Flow rate vs. head for perforation spacing of 30 in. and lateral spacing of 3 ft. The lower curve for each perforation represents the head at the distal end of lateral (Machmeier 1975).

TABLE 9. Friction Loss in Schedule 40 Plastic Pipe (C = 150)

Flow gpm	Pipe Diameter (in)								
	1	1 1/4	1 1/2	2	3	4	6	8	10
1	0.07								
2	0.28	0.07							
3	0.60	0.16	0.07						
4	1.01	0.25	0.12						
5	1.52	0.39	0.18						
6	2.14	0.55	0.25	0.07					
7	2.89	0.76	0.36	0.10					
8	3.63	0.97	0.46	0.14					
9	4.57	1.21	0.58	0.17					
10	5.50	1.46	0.70	0.21					
11		1.77	0.84	0.25					
12		2.09	1.01	0.30					
13		2.42	1.17	0.35					
14		2.74	1.33	0.39					
15		3.06	1.45	0.44	0.07				
16		3.49	1.65	0.50	0.08				
17		3.93	1.86	0.56	0.09				
18		4.37	2.07	0.62	0.10				
19		4.81	2.28	0.68	0.11				
20		5.23	2.46	0.74	0.12				
25			3.75	1.10	0.16				
30			5.22	1.54	0.23				
35				0.05	0.30	0.07			
40				2.62	0.39	0.09			
45				3.27	0.48	0.12			
50				3.98	0.58	0.16			
60					0.81	0.21			
70					1.08	0.28			
80					1.38	0.37			
90					1.73	0.46			
100					2.09	0.55	0.07		
125						0.85	0.12		
150						1.17	0.16		
175						1.56	0.21		
200							0.28	0.07	
250							0.41	0.11	
300							0.58	0.16	
350							0.78	0.20	0.07
400							0.99	0.26	0.09
450							1.22	0.32	0.11
500								0.38	0.14
600								0.54	0.18
700								0.72	0.24
800									0.32
900									0.38
1000									0.46

Velocities in this area become to great for the various flow rates and pipe diameter.

Check valves must be removed from the pump so the manifold and pipe will drain back into the chamber or below frost line. Otherwise, freezing will occur in the manifold.

Pump and Alarm Control: The control system for the pumping chamber consists of a control for operating the pump and an alarm system to detect when the system is malfunctioning.

Pump controls must be selected which give flexibility in adjusting the on-off depth. This adjustment is necessary because of the (a) different sized tanks used and (b) the different dosing quantities for the various sized systems. Without this flexibility, dosing quantity and rates cannot be adjusted, thus resulting in too small a dose or too large a dose.

The types of controls vary in capability and cost. The more flexible and trouble-free controls usually cost more. Selection should be based on reliability and adjustability. Some of the types are:

- a. The mercury level control. This is probably the most reliable and trouble-free switch. It consists of a mercury switch sealed inside a polyethylene bulb which hangs from above. It is strictly an on-off switch, so two of these are required, one to turn the pump on and another to shut it off. The distance between is adjustable, thus they can be set for any given quantity per dose.
- b. The pressure diaphragm switch. This switch has within it a small micro switch which turns on when the hydrostatic pressure on the diaphragm is great enough. Normally it will turn on and off at a small micro switch which turns on when the hydrostatic pressure on the diaphragm is great enough. Normally it will turn on and off at a 6" level differential, thus not giving the necessary flexibility. Switches with larger differentials can be purchased, but they cannot be adjusted on site. A vent tube is imbedded in the electrical cord to provide atmospheric pressure within. The reliability of these switches is somewhat poor due to condensation occurring in the vent tube and leakage around the diaphragm. The switch may or may not be permanently mounted to the pump. Two such switches could be assembled in which one would turn the pump on and the other would shut it off. These could be adjusted to give the proper dose (Fig. 14). This type of switch should not be used in pumping chambers, due to dampness and corrosive conditions.
- c. Adjustable weighted switch. This unit consists of a control located above the water level and two weights attached to a single cable which extends into the liquid. The distance between the weights is adjustable. As the liquid level approaches the upper weight, sufficient buoyancy force is exerted on the weights to lift them. This in turn activates a magnet in the control which turns the pump on. As the liquid level drops, the buoyancy force decreases and the magnet is released, thus shutting off the pump (Fig. 14).

Electrical and Alarm System

The alarm system consists of a switch, a bell and a light in the house which can be easily seen or heard. The switch may consist of one of the above mentioned switches. This system must be on a circuit separate of the pump.

As many of the electrical controls as possible should be placed outside the pumping chamber. Corrosion and condensation are prevalent in the chamber and may cause shortages and may be a possible safety hazard.

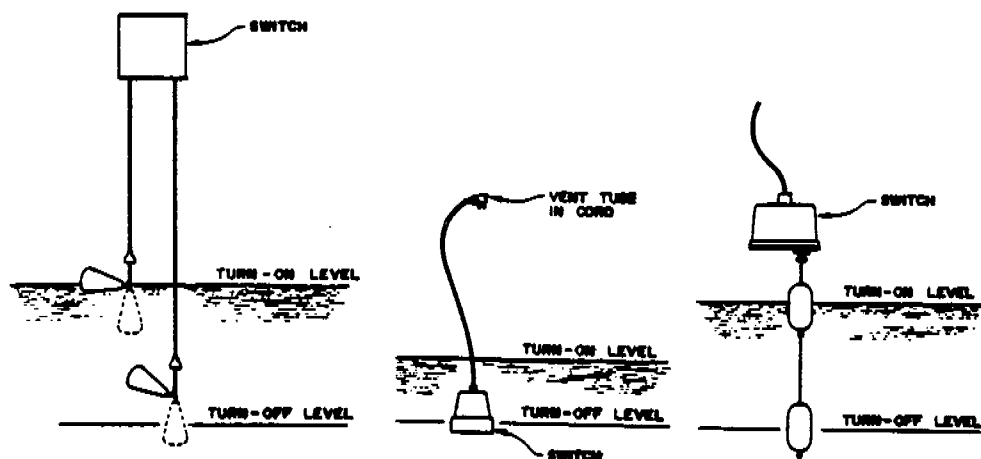

Fig. 14 The Mercury Level Control Switch (left), Pressure Diaphragm Switch (Center) and Adjustable Weighted Switch (right).

Siphons: Siphons can be designed where sufficient elevation exists between the mound and the siphon chamber. However, the siphon must be designed to deliver the same flow rate at the same head at the distribution system as a pump system. The distribution system consisting of manifold and laterals must be designed so they drain after each siphon, otherwise freezing will result in the manifold. This can easily be done by placing the manifold above the laterals.

MOUND CONSTRUCTION TECHNIQUES

Mound construction procedures are just as important as the mound design. Good design with poor construction will result in mound operating poorly and may result in failure. Proper equipment is essential. Small track type tractors work best. Wheel type tractors are too difficult to maneuver in the fill. The following is a step by step procedure for mound construction which has been tried and proven. Other techniques could be used as long as the basic principles of mound design, operation and construction are not violated.

- Select a site which meets the criteria in Table 1.
- Stake out the mound on this site so that the trenches or bed runs perpendicular to the direction of the slope. Reference stakes are recommended in case corner stakes are disturbed.
- Measure the average ground elevation along the upslope edge of bed or upper trench. This is necessary to determine the bottom elevation of the trenches or bed.
- Determine where the pipe from the pumping chamber connects to the distribution system in the mound.
- Trench and lay the effluent pipe from pumping chamber to mound. Cut and cap the pipe one ft. beneath the ground surface. Lay pipe below frost line or sloping uniformly back to the pumping chamber so that it drains after dosing. Backfill and compact soil around pipe to prevent back seepage of effluent along pipe. This step must be done before plowing to avoid compacting and disturbance of surface. Fig. 15.
- Check the moisture content of the soil at 7-8 in. deep. If it is too wet, smearing and compaction will result, thus reducing the infiltration capacity of the soil. Soil moisture can be determined by rolling a soil sample between the hands. If it rolls into a ribbon, the site is too wet to prepare. If it crumbles, soil preparation can proceed.
- Cut trees to ground level, remove excess vegetation by mowing. Prepare the site using a moldboard plow by plowing perpendicular to the slope. Chisel plowing may be used if a moldboard plow is not available. Roto-tilling must not be done on heavy soils but can be used on non-structural soils such as sands. Immediate construction after plowing is desirable. Avoid rutting of plowed area with vehicular traffic. Fig. 16.
- Extend the effluent pipe to several feet above the ground surface.
- Place the fill material which has been properly selected around the edge of the plowed area. Keep wheels of truck off plowed areas. Minimize traffic on the downslope side of mound. Work from the end and upslope side. Fig. 16.
- Move the fill material into place using a small track type tractor with

a blade. Always keep a minimum of 6 in. of sand beneath tracks to prevent compaction of the natural soil. Fig. 17.

- Place the fill material to the required depth which is the top of the trenches or bed. Shape sides to the desired slope. Fig. 18.

- With the blade of the tractor form the bed or trenches. Hand level the bottom of the trenches and beds. Make sure bottoms are at the same elevation and level. Fig. 19 & 20.

- Place the coarse aggregate in the trenches or bed. It should be 1/2-2 in. non-deteriorating aggregate. This is the same aggregate as recommended for the conventional system. Level aggregate to the design depth. Fig. 21.

- Place the distribution system on the aggregate. Connect the manifold to the pipe from pumping chamber. Slope manifold to effluent pipe. Lay laterals fairly level, removing large rises and dips. Fig. 22.

- Place 2 in. of aggregate over the distribution pipe. Fig. 22.

- Place 4-5 in. of uncompacted straw or marsh hay, untreated building paper or a synthetic fabric, such as Typar, Mirafi or the equivalent over aggregate.

- Place soil on top of the bed or trench to a depth of 1 ft. in center and 6 in. at outer edge of bed or trenches. This may be a subsoil or top soil. Fig. 23.

- Place 6 in. of good quality top soil over the entire mound surface. This will raise the elevation at the center of the mound to a minimum of 1.5 ft. (H) and the outside edges of bed or trenches to 1 ft. (G). Fig. 23.

- Landscape the mound by planting grass, using the best vegetation adaptable to the area. A mixture of 90% birdsfoot trefoil and 10% timothy may be desirable if the mound is not manicured. If manicuring is desired, a combination of 60% bluegrass, 30% creeping red fescue and 10% annual rye grass may be the desired vegetative cover. Shrubs can be planted around the base and up the sideslopes. They should be somewhat moisture tolerant since the toe of the mound may be somewhat moist during various times of the year. Fig. 25.

- Mound maintenance involves pumping the septic tank every 3 years to avoid carryover of solids into the mound. A good water conservation plan within the house assures mound will not be overloaded. Avoid excess traffic in mound area. Winter traffic on mound should be avoided to minimize frost penetration.



Fig. 15 Trench and lay the pipe from the pumping chamber to the mound system. Refill trench and compact soil to avoid settling under mound.



Fig. 16 Plow the area beneath the mound, using a mold board or chisel plow. Plow on the contour on sloping sites. Do not drive on plowed area. Note how sand is dumped along the edge of plowed layer.



Fig. 17 Using crawler tractor, move sand into place. Maintain 6 in. of sand between tracks and plowed soil to minimize compaction.



Fig. 18 Place sand to required depth and shape sides.



Fig. 19 View showing trenches in sand. These can be placed using a crawler tractor with blade. A wheel tractor will not work.



Fig. 20 Hand leveling and shaping of trench bottom is essential to get a level surface. Machine cannot get a level bottom so some hand shaping is necessary. (Pipes are observation tubes in a research project.)

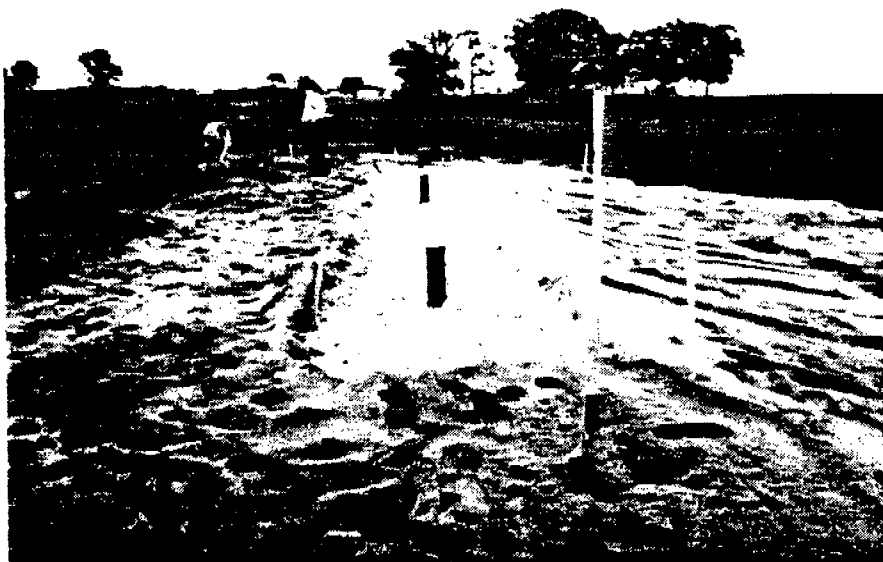

Fig. 21 View of stone in trench prior to final leveling.



Fig. 22 Placement of distribution pipe in trench or bed. For trenches, there is normally only one lateral on each side of the manifold.



Fig. 23 Placement of topsoil on mound. Note layer of hay or straw on top of rocks prior to placement of soil. Blade on crawler is superior to bucket for leveling. Tractor with wheels should not be used, as it ruts up the mound too much.



Fig. 24 View of finished mound prior to final hand leveling and seeding.

DESIGN EXAMPLE AND PLANS

for

MOUND

on

SLOWLY PERMEABLE SOIL

DESIGN EXAMPLE
for
MOUND
on
SLOWLY PERMEABLE SOIL

An example is used to illustrate the design procedure. The method outlined in the text is followed step by step for a situation commonly found in practice. Example plans have also been prepared for most site conditions encountered and are included following the design example. These prepared plans may be used where similar site conditions exist. In cases where these plans cannot be adapted to the site, a mound may be designed as illustrated below.

Design a mound system for a 3 bedroom home with the following site conditions. Several small trees are on the site. Rock fragments, impermeable layer, and bedrock are not a factor. (Letter Notation on Fig. A.3 and A.4 are used as references in this example).

Slope	6%
Percolation Rate	120 min/in. at 24 inches*
Ground Water	24 in.

Step 1. Select the Site

The mound site should be selected prior to house location and road building. Consider all criteria listed in Table 1 and the discussion under the "Soil and Site Requirement" section for all possible locations on the lot. Consider the difficulties in construction of the mound at the various locations. Evaluate all criteria, weigh one site against the other, then pick the best site.

Step 2. Waste Water Load

Design loading is 150 gal/day/bedroom, so with 3 bedrooms the design loading is 450 gal/day.

Step 3. Select the Fill Material

Select a medium sand texture. Use Table 2 as a guide. Sometimes it is necessary to make a judgement on the quality of sand versus the transportation costs, but there are sands which are too coarse or too fine that are not acceptable. A medium sand texture will have a design infiltration rate of 1.2 gal/ft²/day.

Step 4. Size the Absorption Area

Since the medium textured sand is being used, the infiltration rate is 1.2 gal/ft²/day.

*Unless there is a more restrictive horizon above.

$$\text{Absorption area required} = 450 \text{ gal/day} \div 1.2 \text{ gal/ft}^2/\text{day} = 375 \text{ ft}^2$$

Since this is a slowly permeable soil with high ground water, a trench system must be used. This will spread the liquid out along the slope and minimize the encroachment of the ground water into the mound. Trench width of 2-4 ft is permissible.

Use a trench width of 3 ft. (A) then:

$$\text{trench length} = 375 \text{ ft}^2 \div 3 \text{ ft.} = 125 \text{ ft.}$$

This is too long for a trench system. Use 2 or 3 parallel trenches of equal length, preferably 2 trenches. More than 3 trenches may concentrate the liquid into a small area and also result in higher mounds on sloping sites.

For a 2 trench system:

$$\text{Trench length} = 125 \text{ ft.} \div 2 \text{ ft.} = 62.5 \text{ ft. (B)}$$

Trench spacing is determined by the design loading rate of the natural soil. For a soil with percolation rate of 120 min/in., the design infiltration rate is 0.24 ft²/day. All of the effluent from the upslope trench must be absorbed by the natural soil before it reaches the downslope trench through lateral movement. Assume one-half of effluent in each trench.

$$\begin{aligned} \text{Trench spacing} &= 225 \text{ gal/day} \div 0.24 \text{ gal/ft}^2 \div 62.5 \text{ ft.} \\ &= 15 \text{ ft. (C) from center to center} \end{aligned}$$

Step 5. Mound Height

$$\text{Fill depth (D)} = 1 \text{ ft. (min. fill depth beneath absorption area)}$$

$$\begin{aligned} \text{Fill depth (E)} &= D + \text{slope (C+A)} \\ &= 1 \text{ ft.} + .06 (15+3) \text{ ft.} \\ &= 1 \text{ ft.} + 1.1 \\ &= 2.1 \text{ ft. (this is approximate as trenches} \\ &\quad \text{must be at same elevation)} \end{aligned}$$

$$\text{Trench depth (F)} = 0.75 \text{ ft. minimum depth with a min. of 0.5 ft. of aggregate below distribution system.}$$

$$\text{Cap and top soil depth (H)} = 1.5 \text{ ft. which include 1 ft. of subsoil and 0.5 ft. of top soil.}$$

$$\text{Cap and top soil depth (G)} = 1.0 \text{ ft. which include 0.5 ft. of subsoil and 0.5 ft. of top soil.}$$

Step 6. Mound Length and Width

$$\begin{aligned}
 \text{End Slopes (K)} &= \text{mound depth at center} \times 3:1 \text{ slope.} \\
 &= ((D+E) \div 2 + F + H) \times 3 \\
 &= 3.8 \text{ ft.} \times 3 \\
 &= 11.4 \text{ ft.}
 \end{aligned}$$

$$\begin{aligned}
 \text{Upslope Width (J)} &= \text{mound depth at upslope edge} \times 3:1 \text{ slope} \\
 &\quad \times \text{slope correction (Table 3)} \\
 &= (D+F+G) \times 3 \times 0.85 \\
 &= 2.8 \text{ ft.} \times 3 \times 0.85 \\
 &= 7 \text{ ft.}
 \end{aligned}$$

$$\begin{aligned}
 \text{Downslope Width (I)} &= \text{mound depth at downslope edge} \times 3:1 \\
 &\quad \text{slope} \times \text{slope correction (Table 3)} \\
 &\quad (E+F+G) \times 3 \times 1.22 \\
 &= 3.9 \text{ ft.} \times 3 \times 1.22 \\
 &= 14 \text{ ft.}
 \end{aligned}$$

$$\begin{aligned}
 \text{Mound Length (L)} &= B + 2 K \\
 &= 62.5 \text{ ft.} + 2 \times 11.4 \text{ ft.} \\
 &= 85 \text{ ft.}
 \end{aligned}$$

$$\begin{aligned}
 \text{Mound Width (W)} &= J + A/2 + C + A/2 + I \\
 &= 7 \text{ ft.} + 1.5 \text{ ft.} + 15 \text{ ft.} + 1.5 \text{ ft.} + 14.1 \text{ ft.} \\
 &\quad (\text{C is center to center of trenches}) \\
 &= 39 \text{ ft.}
 \end{aligned}$$

Step 7. Basal Area

On sloping sites the basal area is that area under and down-slope of the trenches ($B \times (C+A+I)$). On level sites it is the total area under the mound ($B \times W$) except for end areas. The design loading rate of the soil with percolation rate of 120 min/in. is 0.24 gal/ft²/day.

$$\begin{aligned}
 \text{Basal Area Required} &= \text{daily flow} \div \text{infiltrative capacity of} \\
 &\quad \text{soil} \\
 &= 450 \text{ gal/day} \div 0.24 \text{ gal/ft}^2/\text{day} \\
 &= 1875 \text{ ft}^2
 \end{aligned}$$

$$\begin{aligned}
 \text{Basal Area Available} &= B \times (C+A+I) \\
 &= 62.5 \text{ ft.} \times (15 \text{ ft.} + 3 \text{ ft.} + 14 \text{ ft.}) \\
 &= 2006 \text{ ft}^2
 \end{aligned}$$

Sufficient area is available. If it were not, then the down-slope width (I) would be increased until sufficient area is available.

Step 8. Distribution System

Fig. 11 and A. 7 shows typical examples of a distribution system. Design requires selection of hole spacing and diameter, lateral diameter and spacing, manifold length and diameter. Lateral length is defined as the distance from manifold (supply end) to far (distal) end. Tee to Tee construction is preferred. For systems larger than 5 bedroom residential, procedure outlined by Otis et al. (1978) must be used.

Hole spacing = 30 in.
Hole diameter = 1/4 in.

Lateral length -

Lateral lengths normally are about 0.5 feet shorter than one-half the length of trench. In this example, lateral length would be 30.5 ft. (62.5 ft. ÷ 2 -.5 ft.).

Hole Spacing -

Holes are spaced 30 in. apart.

The following are hole spacing distances in inches from the manifold to distal end of lateral. There are 13 holes per lateral.

15, 45, 75, 105, 135, 165, 195, 225, 255, 285, 315,
345, 366*

*If the last hole, based on 30 in. spacing, is equal to or greater than 15 in. from the end of the lateral, put another hole in the end cap of the pipe or close to it.

Lateral Diameter

Lateral diameters are dependent upon lateral length, hole size and spacing. Table 4 gives the maximum allowable length for various hole diameters and hole spacing. For the 30 in. spacing and 1/4 in. hole, allowable lateral lengths for 1 in. diameter is 25 ft. and for 1 1/4 in. diameter is 38 feet. Since lateral lengths required is 30.5 ft., the lateral diameter must be 1 1/4 in.

Lateral Spacing

For trench systems, lateral spacing is from center to center of trenches. For this example, it is 15 ft.

Manifold Length

Manifold length is distance between the outside laterals or summation of all lateral spacings. For this example, it would be 15 ft.

Manifold Diameter

For these mound systems, the manifold diameter is normally 2 or 3-in., depending on the size of the pipe from the pumping chamber to the mound and the inlet location. The inlet can be in the side of the manifold between the laterals (Fig. 11 or A.7), or it can be in the end of the manifold, preferably on the upslope edge. In either case, the manifold must slope toward the inlet so it will drain. For either inlet location, the manifold can be 2-in. diameter if the pipe is 2-in. diameter. If the pipe from the pump is 3-in. diameter, and the inlet is in the end, then the manifold must be 3-in. If the inlet is in the side, then the manifold can be 2-in. diameter. For larger systems, (greater than 5 bedroom size), friction losses in manifold must be considered.

Step 9. Pumping Chamber Size

Table 7 gives the recommended pumping chamber size which is 500-750 gal. capacity. The features shown in Fig. 12 should be incorporated into it.

Step 10. Pump Size

Assume the pumping chamber is located 75 ft. from the mound center and the elevation difference is 9 ft. from the pump to the lateral invert.

Pump Capacity

Using the recommended pressure of 2 ft. at the distal end of the lateral, Table 8 gives the pump capacity of 54 gpm for 1/4-in. diameter holes for a 3 bedroom sized mound. Fig. 13 can be used to determine flow rate for other pressures.

Pump Head

The total head consists of (1) elevation difference, (2) friction loss, and (3) desired pressure at end of laterals.

(1) elevation head = 9 ft.

(2) friction loss -

Friction loss is dependent upon flow rate and pipe diameter.

Table 9 gives the friction loss/100 ft. of pipe for various diameter pipes and flow rates. For flow rate of 54 gpm, the friction loss for:

(a) 2-in. diameter is $3.98 \text{ ft}/100 \text{ ft.} \times 75 \text{ ft.} = 3.0 \text{ ft.}$

(b) 3-in. diameter is $.67 \text{ ft}/100 \text{ ft.} \times 75 \text{ ft.} = .5 \text{ ft.}$

Either pipe can be used. Ignore friction losses for fittings. Manifold friction loss can be estimated by adding its length to the pipe length when figuring friction loss.

(3) Pressure at distal end of lateral

Fig. 13 can be used to determine pressure at supply end of lateral. For a 2 ft. pressure at distal end for 1/4-in. diameter holes, the pressure at supply end is 2.5 ft.

Total Head = 9 ft. + 3 ft. + 2.5 ft. = 14.5 ft. for 2-in. diameter pipe.
 = 9 ft. + .5 ft. + 2.5 ft. = 12 ft. for 3-in. diameter pipe.

Pump size

Select a pump which would pump at least 54 gpm at 14.5 ft. of head. This given head loss is based on using a 2 in. pipe. The pump opening will be smaller.

or

Select a pump which would pump at least 54 gpm at 12 ft. of head. This given head loss is based on using a 3 in. pipe. The pump opening will be smaller.

Step 11. Dosing Quantity

From Table 5, the net recommended dosing quantity is 115 gal/dose. The void volume of the laterals needs to be checked to see if the dosing quantity is 10 times the void volume. From Table 6, the void volume of 1-1/4 in. diameter pipe is .064 gal/ft. For 122 feet of lateral, the void volume is 7.7 gal which, when multiplied by 10, is less quantity given in Table 5. Therefore, the volume is 115 gal/dose. Adjustments need to be made for flow back so 115 gal is actually dosed. For a 5-ft. diameter pumping chamber, the net liquid level differential per dose cycle is 9.4 in.

Step 12. Select the controls which will give the flexibility necessary for the proper quantity per dose (Fig. 14).

TABLE A-1. DESIGN CRITERIA FOR A MOUND FOR A 1 BEDROOM HOME ON 0 TO 6% SLOPE WITH LOADING RATES UP TO 150 GAL/DAY FOR SLOWLY PERMEABLE SOIL Fig. A.1 and A.2.

PARAMETER	SYMBOL	UNITS	SLOPE %			
			0	2	4	6
Trench Width	A	Ft	3	3	3	3
Trench Length	B	Ft	42	42	42	42
No. of Trenches	-	-	1	1	1	1
Mound Height	D	Ft	1	1	1	1
	F	Ft	0.75	0.75	0.75	0.75
	G	Ft	1	1	1	1
	H	Ft	1.5	1.5	1.5	1.5
Mound Width	J	Ft	11*	8	8	8
	I*	Ft	11	15	15	15
	W	Ft	25	26	26	26
Mound Length	K	Ft	10	10	10	10
	L	Ft	62	62	62	62
Lateral Length	P	Ft	20.	20.	20.	20.
Lateral Diameter	-	In	1	1	1	1
No. of Holes per Lateral**	-	-	9	9	9	9
Hole Spacing	-	In	30	30	30	30
Hole Diameter**	-	In	1/4	1/4	1/4	1/4

* Additional width to obtain required basal area

** Last hole is located at end of lateral which is 15" from other hole

TABLE A-2. DESIGN CRITERIA FOR A MOUND FOR A 2 BEDROOM HOME ON 0 TO 6% SLOPE WITH LOADING RATES TO 300 GAL/DAY FOR SLOWLY PERMEABLE SOIL
Fig. A.3 and A.4

PARAMETER	SYMBOL	UNITS	SLOPE %			
			0	2	4	6
Trench Width	A	Ft	3	3	3	3
Trench Length	B	Ft	42	42	42	42
No. of Trenches	-	-	2	2	2	2
Trench Spacing	C	Ft	15	15	15	15
Mound Height	D	Ft	1	1	1	1
	E	Ft	1	1.4	1.7	2.1
	F	Ft	0.75	0.75	0.75	0.75
	G	Ft	1	1	1	1
	H	Ft	1.5	1.5	1.5	1.5
Mound Width	J	Ft	12	8	8	8
	I*	Ft	12	20	20	20
	W	Ft	42	46	46	46
Mound Length	K	Ft	10	10	10	10
	L	Ft	62	62	62	62
Lateral Length	P	Ft	20	20	20	20
Lateral Diameter	-	In	1	1	1	1
No. of Holes per Lateral**	-	-	9	9	9	9
Hole Spacing**	-	In	30	30	30	30
Hole Diameter	-	In	1/4	1/4	1/4	1/4
Manifold Length	R	Ft	15	15	15	15
Manifold Diameter***	-	In	2	2	2	2

* Additional Width to obtain required basal area

** Last hole is located at end of lateral which is 15" from other hole

*** Diameter dependent upon size of pipe from pump and inlet position

TABLE A-3. DESIGN CRITERIA FOR A MOUND FOR A 3 BEDROOM HOME ON A 0 TO 6% SLOPE WITH LOADING RATES OF 450 GAL/DAY FOR SLOWLY PERMEABLE SOILS.
Fig. A.3 and A.4.

PARAMETER	SYMBOL	UNITS	SLOPE %			
			0	2	4	6
Trench Width	A	Ft	3	3	3	3
Trench Length	B	Ft	63	63	63	63
No. of Trenches	-	-	2	2	2	2
Trench Spacing	C	Ft	15	15	15	15
Mound Height	D	Ft	1	1	1	1
	E	Ft	1	1.4	1.7	2.1
	F	Ft	.75	.75	.75	.75
	G	Ft	1	1	1	1
	H	Ft	1.5	1.5	1.5	1.5
Mound Width	J	Ft	12*	8	8	8
	I*	Ft	12	20	20	20
	W	Ft	42	46	46	46
Mound Length	K	Ft	10	10	10	10
	L	Ft	83	83	83	83
Lateral Length	P	Ft	31	31	31	31
Lateral Diameter	-	In	1-1/4	1-1/4	1-1/4	1-1/4
No. of Hole per Lateral**	-	-	14	14	14	14
Hole Spacing**	-	In	30	30	30	30
Hole Diameter	-	In	1/4	1/4	1/4	1/4
Manifold Length	R	Ft	15	15	15	15
Manifold Diameter***	-	In	2	2	2	2

* Additional width to obtain required basal area.

** Last hole is located 27" from previous one.

*** Diameter dependent upon size of pipe from pump and inlet position.

TABLE A-4. DESIGN CRITERIA FOR A MOUND FOR A 4 BEDROOM HOME ON A 0 TO 6% SLOPE WITH LOADING RATES OF 600 GAL/~~MIN~~ DRY FOR SLOWLY PERMEABLE SOILS. Fig. A.5 and A.6.

PARAMETER	SYMBOL	UNITS	SLOPE %			
			0	2	4	6
Trench Width	A	Ft	3	3	3	3
Trench Length	B	Ft	56	56	56	56
No. of Trenches	-	-	3	3	3	3
Trench Spacing	C	Ft	15	15	15	15
Mound Height	D	Ft	1	1	1	1
	E	Ft	1	1.7	2.3	3.0
	F	Ft	.75	.75	.75	.75
Mound Width	G	Ft	1	1	1	1
	H	Ft	2	2	2	2
	J	Ft	12*	8	8	8
Mound Length	I*	Ft	12	20	20	20
	W	Ft	57	61	61	61
	K	Ft	12	12	12	14
Lateral Length	L	Ft	80	80	80	84
	P	Ft	27.5	27.5	27.5	27.5
Lateral Diameter	-	In	1-1/4	1-1/4	1-1/4	1-1/4
No. of Holes per Lateral**	-	-	12	12	12	12
Hole Spacing**	-	In	30	30	30	30
Hole Diameter	-	In	1/4	1/4	1/4	1/4
Manifold Length	R	Ft	30	30	30	30
Manifold Diameter***	-	In	2	2	2	2

* Additional width to obtain required basal area

** Last hole is located at end of lateral which is 15" from previous hole.

*** Diameter dependent upon size of pipe from pump and inlet position.

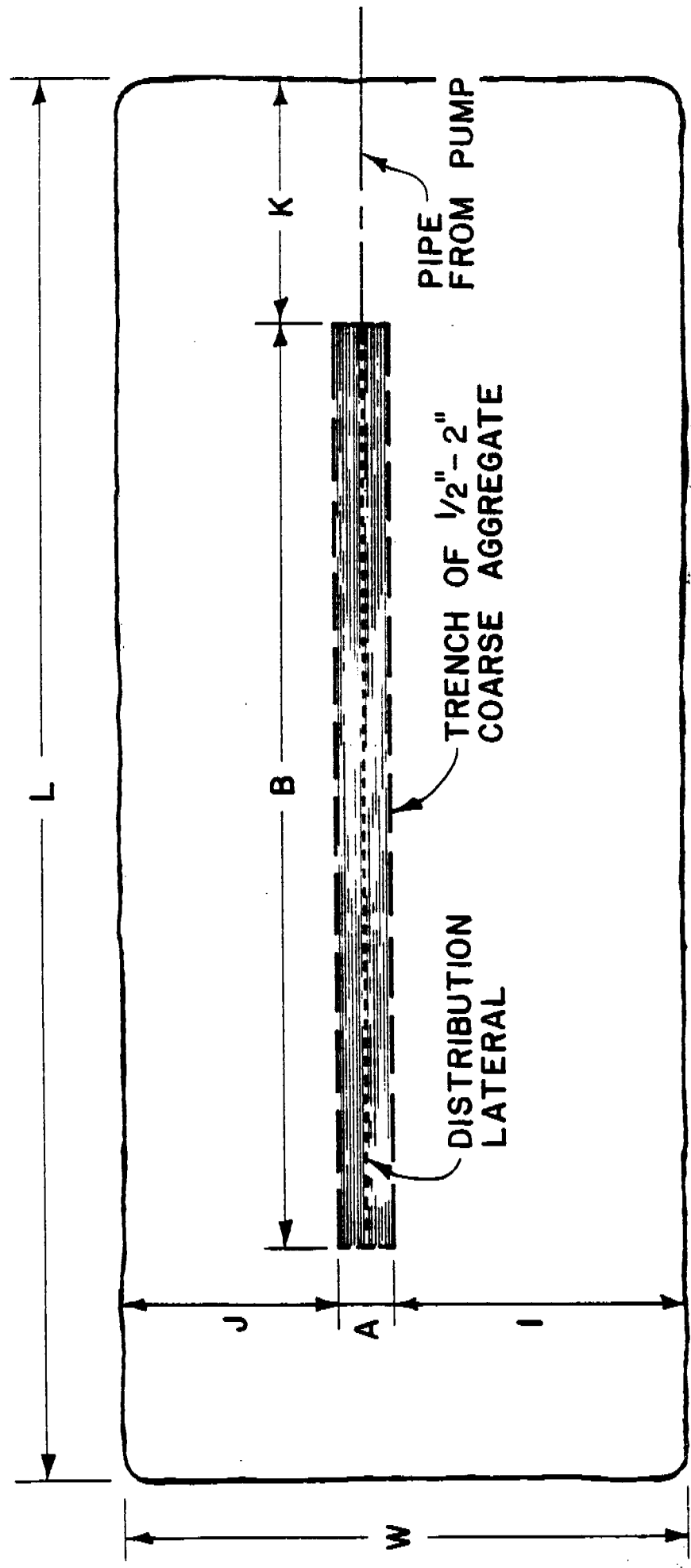

Fig. A.1 Plan view of a mound using 1 trench for absorption area.

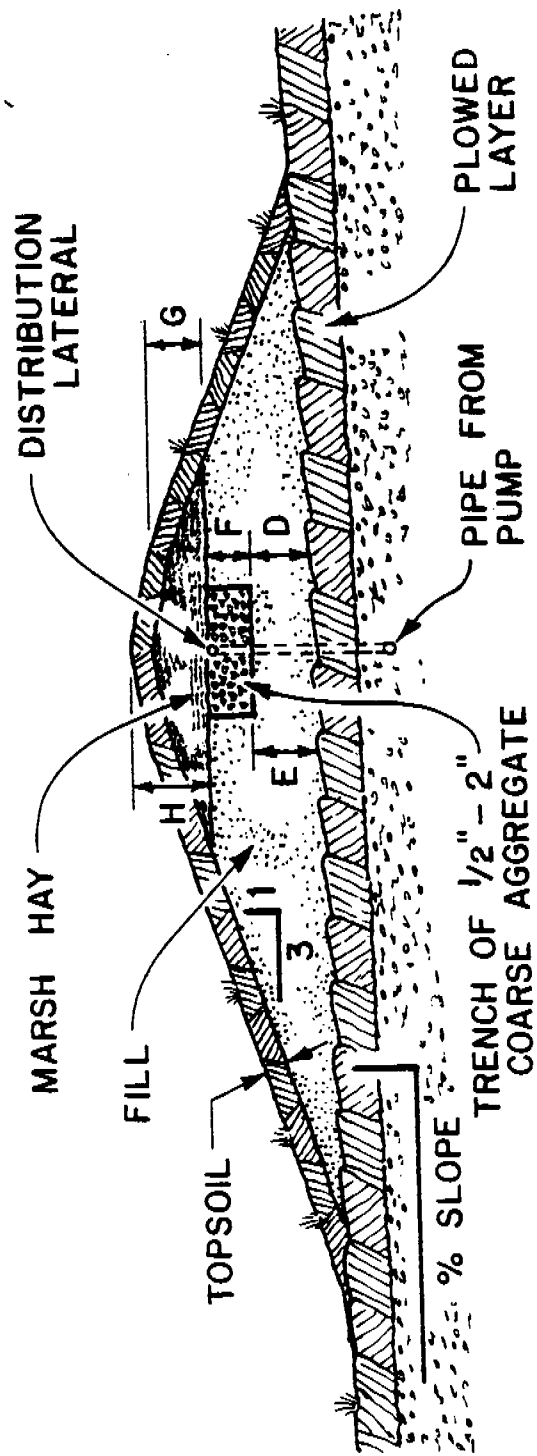

Fig. A.2 Cross section of a mound using 1 trench for absorption area.

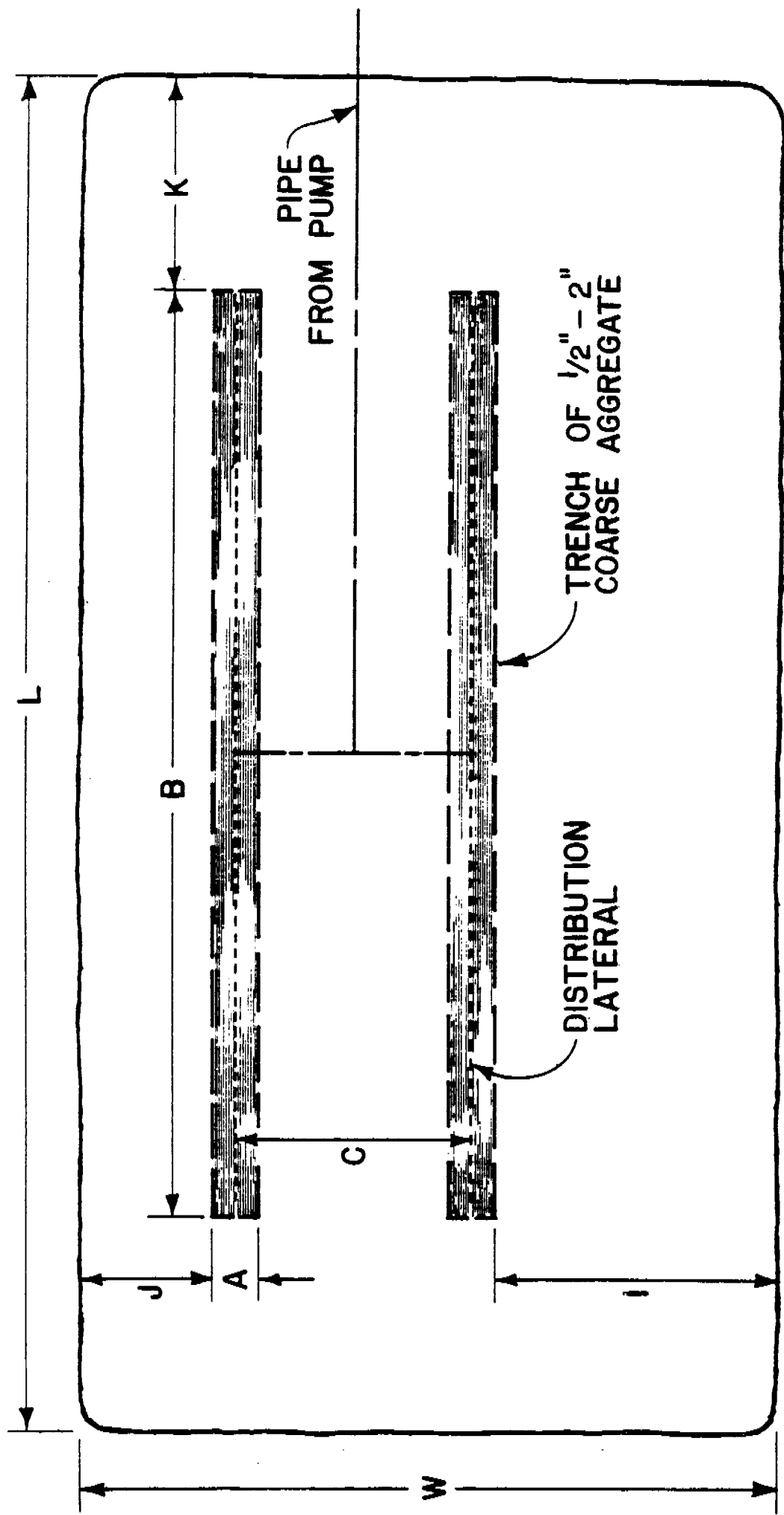

Fig. A. 3 Plan view of a mound system using 2 trenches for the absorption area.

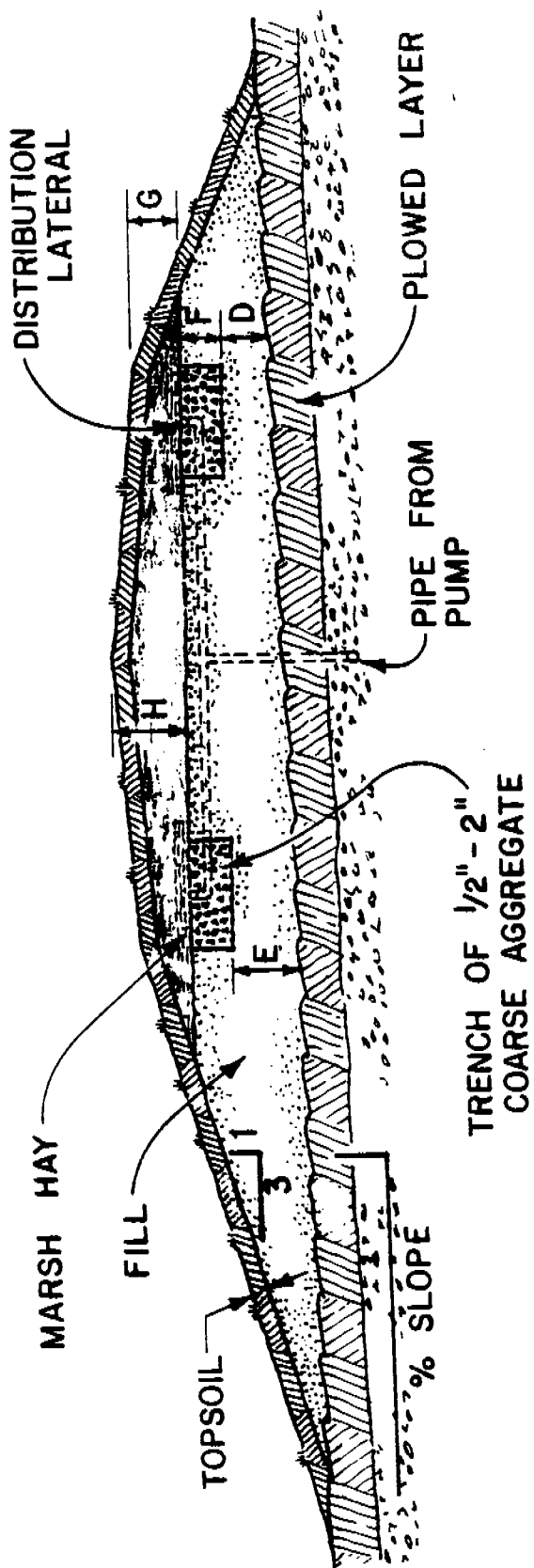

Fig. A. 4 Cross section of a mound system using 2 trenches for the absorption area.

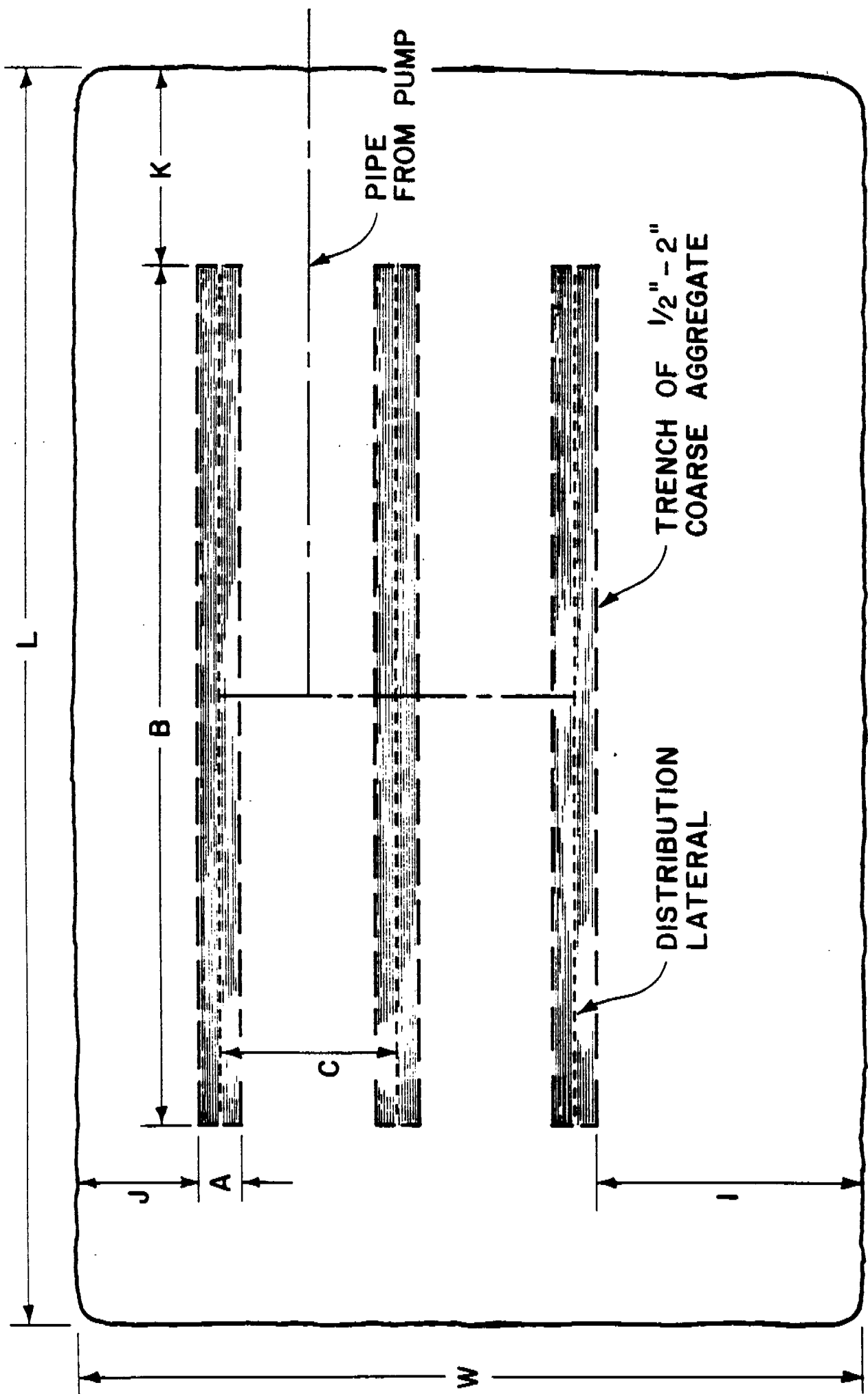

Fig. A. 5 Plan view of a mound system using 3 trenches for the absorption area.

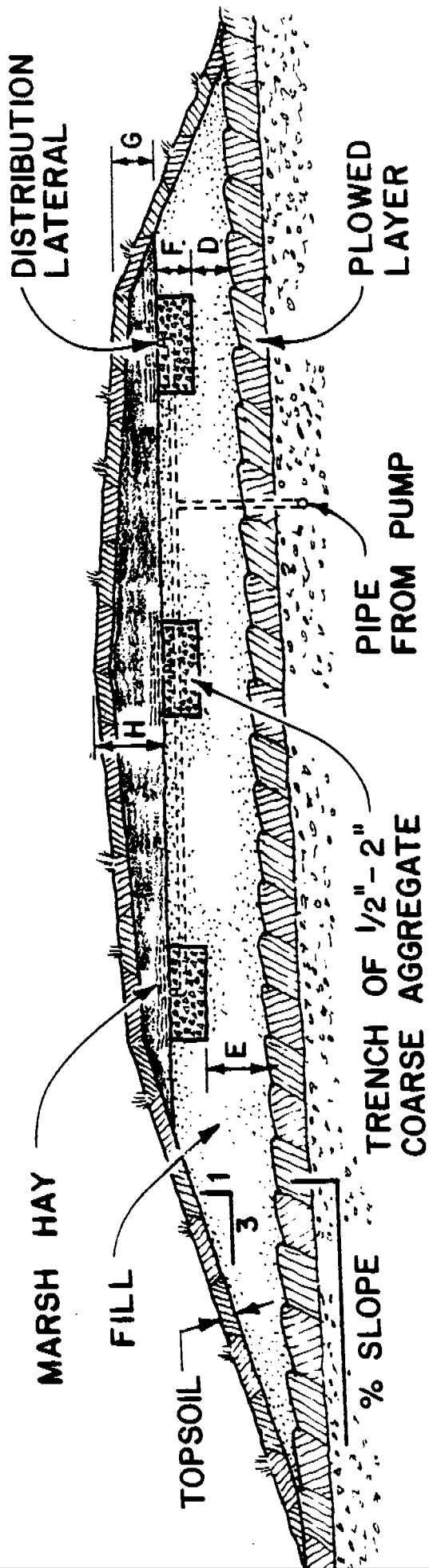
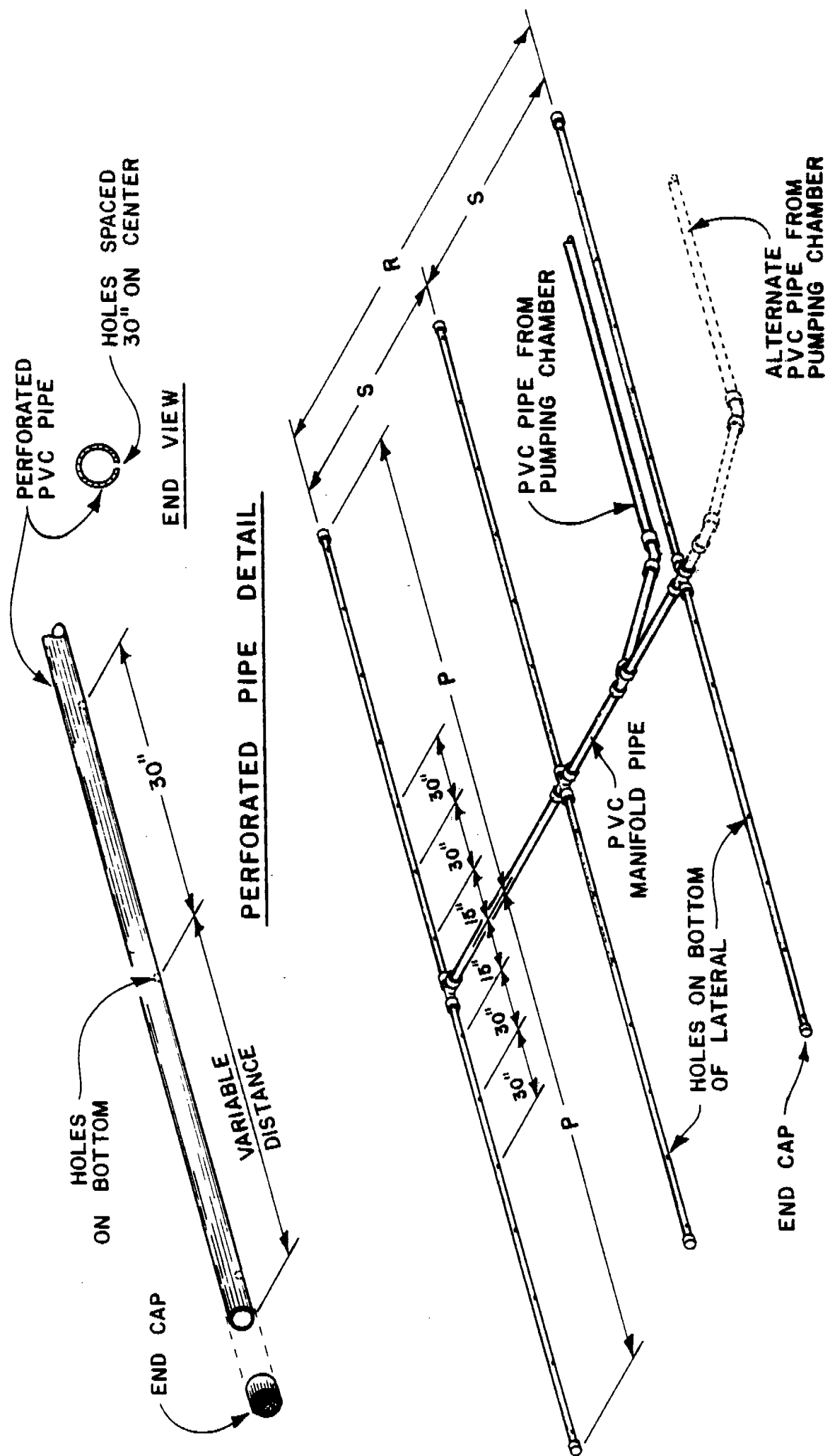

Fig. A. 6 Cross section view of a mound system using 3 trenches for the absorption area.



PIPE LATERAL LAYOUT

Fig. A. 7 The distribution system for a mound. One lateral is placed down the center of each trench as shown on plan views. Note alternate inlet positions. The variable distance between the last hole and the next to last hole will range between 15 and 30 in., depending upon the length of trench. Distribution system must be arranged so manifold and laterals drain after each dose.

DESIGN EXAMPLE AND PLANS
for
MOUND
on
SHALLOW PERMEABLE SOIL OVER CREVICED BEDROCK

DESIGN EXAMPLE
for
MOUND
on
PERMEABLE SHALLOW SOIL OVER CREVICED BEDROCK

An example is used to illustrate the design procedure. The method outlined in the text is followed step by step for a situation commonly found in practice. Example plans have also been prepared for most site conditions encountered and are included following the design example. These prepared plans may be used where similar site conditions exist. In cases where these plans cannot be adapted to the site, a mound may be designed as illustrated below.

Design a mound system for a 3 bedroom home with the following site conditions. Several small trees are on the site. Rock fragments, impermeable layer, and bedrock are not a factor. (Letter Notation on Fig. B.1, B.2 and B.3.

Slope	6%
Percolation Rate	50 min/in. at 12 in.
Creviced bedrock	24 in.

Step 1. Select the Site

The mound site should be selected prior to house location and road building. Consider all criteria listed in Table 1 and the discussion under the "Soil and Site Requirement" section for all possible locations on the lot. Consider the difficulties in construction of the mound at the various locations. Evaluate all criteria, weigh one site against the other, then pick the best site.

Step 2. Waste Water Load

Design loading is 150 gal/day/bedroom, so with 3 bedrooms the design loading is 450 gal/day.

Step 3. Select the Fill Material

Select a medium sand texture. Use Table 2 as a guide. Sometimes it is necessary to make a judgement on the quality of sand versus the transportation costs, but there are sands which are too coarse or too fine that are not acceptable. A medium sand texture will have a design infiltration rate of 1.2 gal/ft²/day.

Step 4. Size the Absorption Area

Since the medium sand texture is being used, the infiltration rate is 1.2 gal/ft²day.

Absorption area required = 450 gal/day ÷ 1.2 gal/ft²/day = 375 ft²

Since high ground water isn't a problem, the bed can be square or rectangular. On sloping sites with heavier soils where there is a possibility of some lateral movement before the effluent reaches the creviced bedrock, a rectangular shape mound may be desirable. This example will use a rectangular design.

Use a bed width of 12 ft. then:

$$\text{bed length} = 375 \text{ ft}^2 \div 12 \text{ ft.} = 32 \text{ ft.}$$

Step 5. Mound Height

Fill depth (D) = 2 ft. (min. fill depth beneath absorption area.)

$$\begin{aligned} \text{Fill depth (E)} &= D + \text{slope (A)} \\ &= 2 \text{ ft.} + .06 (12) \text{ ft.} \\ &= 2 \text{ ft.} + .7 \\ &= 2.7 \text{ ft. (this is approximate as bed must} \\ &\quad \text{be at same elevation)} \end{aligned}$$

Bed depth (F) = 0.75 ft. minimum depth with a min. of 0.5 ft. of aggregate below distribution system.

Cap and top soil depth (H) = 1.5 ft. which include 1 ft. of subsoil and 0.5 ft. of top soil.

Cap and top soil depth (G) = 1.0 ft. which include 0.5 ft. of subsoil and 0.5 ft. of top soil.

Step 6. Mound Length and Width

$$\begin{aligned} \text{End Slopes (K)} &= \text{mound depth at center} \times 3:1 \text{ slope.} \\ &= (D+E \div 2 + F+H) \times 3 \\ &= 4.6 \text{ ft.} \times 3 \\ &= 14 \text{ ft.} \end{aligned}$$

$$\begin{aligned} \text{Upslope Width (J)} &= \text{mound depth at upslope edge} \times 3:1 \text{ slope} \\ &\quad \times \text{slope correction (Table 3).} \\ &= (D+F+G) \times 3 \times 0.85 \\ &= 3.8 \text{ ft.} \\ &= 10 \text{ ft.} \end{aligned}$$

$$\begin{aligned} \text{Downslope Width (I)} &= \text{mound depth at downslope edge} \times 3:1 \text{ slope} \\ &\quad \times \text{slope correction (Table 3)} \\ &= (E+F+G) \times 3 \times 1.22 \\ &= 4.45 \text{ ft.} \times 3 \times 1.22 \\ &= 16 \text{ ft.} \end{aligned}$$

$$\begin{aligned} \text{Mound Length (L)} &= B + 2 K \\ &= 32 \text{ ft.} + (2 \times 14) \text{ ft.} \\ &= 60 \text{ ft.} \end{aligned}$$

$$\begin{aligned}
 \text{Mound Width (W)} &= I + A + J \\
 &= 16 + 12 + 10 \\
 &= 38 \text{ ft.}
 \end{aligned}$$

Step 7. Basal Area

On sloping sites the basal area is that area under and down-slope of the trenches ($B \times (A+I)$). On level sites it is the total area under the mound ($B \times W$) except for end areas. The design loading rate of the soil with percolation rate of 50 min/in. is $0.74 \text{ gal/ft}^2/\text{day}$.

$$\begin{aligned}
 \text{Basal Area Required} &= \text{daily flow} \div \text{infiltrative capacity of soil} \\
 &= 450 \text{ gal/day} \div 0.74 \text{ gal/ft}^2/\text{day} \\
 &= 608 \text{ ft}^2
 \end{aligned}$$

$$\begin{aligned}
 \text{Basal Area Available} &= B \times (A+I) \\
 &= 32 \text{ ft.} \times (12 \text{ ft.} + 16 \text{ ft.}) \\
 &= 896 \text{ ft}^2
 \end{aligned}$$

Sufficient area is available. If it were not, then the down-slope width (I) would be increased until sufficient area is available.

Step 8. Distribution System

Fig. 11 & B.3 shows typical examples of a distribution system. Design requires selection of hole spacing and diameter, lateral diameter and spacing, manifold length and diameter. Lateral length is defined as the distance from manifold (supply end) to far (distal) end. Tee to Tee construction is preferred. For systems larger than 5 bedroom residential, procedure outlined by Otis et al. (1978) must be used.

Hole spacing = 30 in.
Hole diameter = 1/4-in.

Lateral length -

Lateral lengths normally are about 0.5 feet shorter than one-half the length of trench. In this example lateral length would be 15.5 ft. ($32 \text{ ft.} \div 2 - .5 \text{ ft.}$)

Hole spacing -

Holes are spaced 30 in. apart.

The following are hole spacing distances in inches from the manifold to distal end of lateral. There are 7 holes per lateral.

15, 45, 75, 105, 135, 165, 186*

*If the last hole, based on 30 in. spacing, is equal to or greater than 15 in. from the end of the lateral, put another hole in the end cap of the pipe or close to it.

Lateral Diameter

Lateral diameters are dependent upon lateral length, hole size and spacing. Table 4 gives the maximum allowable length for various hole diameters and hole spacing. For the 30 in. spacing and 1/4 in. hole, allowable lateral lengths for 1 in. diameter is 25 ft. and for 1 1/4 in. is 38 ft. Since lateral lengths required is 15.5 ft. the lateral diameter can be 1 in.

Lateral Spacing

Bed is 12 ft. wide, using a maximum spacing of 3 ft. between laterals. Beds will require 4 parallel laterals on each side of manifold.

Manifold Length

Manifold length is distance between the outside laterals or summation of all lateral spacings. For this example, it would be 9 ft.

Manifold Diameter

For these mound systems, the manifold diameter is normally 2 or 3 in. depending on the size of the pipe from the pumping chamber to the mound and the inlet location. The inlet can be in the side of the manifold between the laterals, (Fig. 11 or B. 3) or it can be in the end of the manifold, preferably on the upslope edge. In either case, the manifold must slope toward the inlet so it will drain. For either inlet location, the manifold can be 2 in. diameter if the pipe is 2 in. diameter. If the pipe from the pump is 3 in. diameter, and the inlet is in the end, then the manifold must be 3 in. If the inlet is in the side, then the manifold can be 2 in. diameter. For larger systems (greater than 5 bedroom size), friction losses in manifold must be considered.

Step 9. Pumping Chamber Size

Table 7 gives the recommended pumping chamber size which is 500-750 gal. capacity. The features shown in Fig. 12 should be incorporated into it.

Step 10. Pump Size

Assume the pumping chamber is located 75 ft. from the mound center and the elevation difference is 9 ft. from the pump to the lateral invert.

Pump Capacity

Using the recommended pressure of 2 ft. at the distal end of the lateral, Table 8 gives the pump capacity of 54 gpm for 1/4 in. diameter holes for a 3 bedroom sized mound. Fig. 13 can be used to determine flow rate for other pressures.

Pump Head

The total head consists of (1) elevation difference, (2) friction loss, and (3) desired pressure at end of laterals.

(1) elevation head = 9 ft.

(2) friction loss -

Friction loss is dependent upon flow rate and pipe diameter.

Table 9 gives the friction loss/100 ft. of pipe for various diameter pipes and flow rates. For flow rate of 54 gpm the friction loss is:

(a) 2 in. dia. is 3.98 ft/100 ft. x 75 ft. = 3.0 ft.

(b) 3 in. dia. is .67 ft/ 100 ft. x 75 ft. = .5 ft.

Either pipe can be used. Ignore friction losses for fittings. Manifold friction loss can be estimated by adding its length to the pipe length when figuring friction loss.

(3) Pressure at distal end of lateral

Fig. 13 can be used to determine pressure at supply end of lateral. For a 2 ft. pressure at distal end for 1/4 in. diameter holes, the pressure at supply end is 2.5 ft.

Total Head = 9 ft. + 3 ft. + 2.5 ft. = 14.5 ft. for 2 in. dia. pipe.
 = 9 ft. + .5 ft. + 2.5 ft. = 12 ft. for 3 in. dia. pipe.

Pump Size

Select a pump which would pump at least 54 gpm at 14.5 ft. of head. This given head loss is based on using a 2 in. pipe. The pump opening will be smaller.

or

Select a pump which would pump at least 54 gpm at 12 ft. of head. This given head loss is based on using a 3 in. pipe. The pump opening will be smaller.

Step 11. Dosing Quantity

From Table 5 the net recommended dosing quantity is 115 gal/dose. The void volume of the laterals needs to be checked to see if the dosing quantity is 10 times the void volume. From Table 6 the void volume of 1 1/4" diameter pipe is .041 gal/ft. For 124 feet of lateral, the void volume is 5.1 gal which, when multiplied by 10, is less quantity given in Table 5. Therefore, the volume is 115 gal/dose.

Adjustments need to be made for flow back so 115 gal is actually dosed. For a 5-ft. dia. pumping chamber, the net liquid level differential per dose cycle is 9.4 in.

Step 12. Select the controls which will give the flexibility necessary for the proper quantity per dose (Fig. 14).

TABLE B-1. DESIGN CRITERIA FOR A 1 BEDROOM HOME FOR A MOUND ON 0 TO 12% SLOPE WITH LOADING RATES UP TO 150 GAL/DAY FOR SHALLOW PERMEABLE SOIL OVER CREVICED BEDROCK. B.1, 2, 3 and 4.

PARAMETER	SYMBOL	UNITS	PERCOLATION RATE MIN/IN						
			3-60				3-29		
Slope	-	%	0	2	4	6	8	10 ³	12 ³
Bed Width	A ⁵	Ft	10	10	10	10	10	10	10
Bed Length	B	Ft	13	13	13	13	13	13	13
Mound Height	D	Ft	2	2	2	2	2	2	2
	E	Ft	2	2.2	2.4	2.6	2.8	3.0	3.2
	F	Ft	.75	.75	.75	.75	.75	.75	.75
	G	Ft	1	1	1	1	1	1	1
Mound Width	H	Ft	1.5	1.5	1.5	1.5	1.5	1.5	1.5
	J	Ft	12	11	10	10	9	9	9
	I	Ft	12	13	14	17	18	21	26
Mound Length	W	Ft	34	34	34	37	37	41	45
	K	Ft	12	12	12	13	13	13	15
	L	Ft	37	37	37	39	39	39	43
Lateral Length	p ⁴	Ft	12.5	12.5	12.5	12.5	12.5	12.5	12.5
Lateral Diameter	-	In	1	1	1	1	1	1	1
No. of Holes per Lateral	-	-	6	6	6	6	6	6	6
Lateral Spacing	S	Ft	3	3	3	3	3	3	3
No. of Holes per Lateral ¹	-	Ft	6	6	6	6	6	6	6
Hole Spacing ¹	-	In	30	30	30	30	30	30	30
Hole Diameter	-	In	1/4	1/4	1/4	1/4	1/4	1/4	1/4
Manifold Length	R	Ft	6	6	6	6	6	6	6
Manifold Diameter ²	-	In	2	2	2	2	2	2	2

¹ Last hole is located at end of lateral which is 15" from previous hole

² Diameter dependent upon size of pipe from pump and inlet position.

³ On steep sloping sites of 10-12% it may be desirable to reduce depth D to 1.5 ft so E isn't so great or reduce the width of bed.

⁴ Use a manifold with laterals only on one side.

⁵ Beds can be any desired width.

TABLE B-2. DESIGN CRITERIA FOR A 2 BEDROOM HOME FOR A MOUND ON 0 TO 12% SLOPE WITH LOADING RATES UP TO 300 GAL/DAY FOR SHALLOW PERMEABLE SOIL OVER CREVICED BEDROCK.

PARAMETER	SYMBOL	UNITS	PERCOLATION RATE MIN/IN						
			3-60				3-29		
Slope	-	%	0	2	4	6	8	10 ³	12 ³
Bed Width	A ⁵	Ft	10	10	10	10	10	10	10
Bed Length	B	Ft	25	25	25	25	25	25	25
Mound Height	D	Ft	2	2	2	2	2	2	2
	E	Ft	2	2.2	2.4	2.6	2.8	3.0	3.2
	F	Ft	.75	.75	.75	.75	.75	.75	.75
	G	Ft	1	1	1	1	1	1	1
	H	Ft	1.5	1.5	1.5	1.5	1.5	1.5	1.5
Mound Width	J	Ft	12	11	10	10	9	9	9
	I	Ft	12	13	14	17	18	21	26
	W	Ft	34	34	34	37	37	41	45
Mound Length	K	Ft	12	12	12	13	13	13	15
	L	Ft	49	49	49	51	51	51	55
Lateral Length	P ⁴	Ft	12	12	12	12	12	12	12
Lateral Diameter	-	In	1	1	1	1	1	1	1
No. of Laterals	-	-	6	6	6	6	6	6	6
Lateral Spacing	S	Ft	3	3	3	3	3	3	3
No. of Holes per Lateral ¹	-	-	5	5	5	5	5	5	5
Hole Spacing ¹	-	In	30	30	30	30	30	30	30
Hole Diameter	-	In	1/4	1/4	1/4	1/4	1/4	1/4	1/4
Manifold Length	R	Ft	6	6	6	6	6	6	6
Manifold Diameter ²	-	In	2	2	2	2	2	2	2

¹ End of lateral is 9" from last hole; since it isn't equal to or greater than 15 no hole is placed at end of lateral.

² Diameter dependent upon size of pipe from pump and inlet position.

³ On steep sloping sites of 10-12% it may be desirable to reduce depth D to 1.5 ft so E isn't so great or reduce the width of bed.

⁴ This design is based on a manifold with laterals on both sides. It could be designed using 24 ft laterals with manifold at end.

⁵ Bed can be any desired width.

TABLE B-3. DESIGN CRITERIA FOR A 3 BEDROOM HOME FOR A MOUND ON 0 TO 12% SLOPE WITH LOADING RATES UP TO 450 GAL/DAY FOR SHALLOW PERMEABLE SOIL OVER CREVICED BEDROCK.

PARAMETER	SYMBOL	UNITS	PERCOLATION RATE MIN/IN						
			3-60				3-29		
Slope	-	%	0	2	4	6	8	10 ³	12 ³
Bed Width	A ⁵	Ft	10	10	10	10	10	10	10
Bed Length	B	Ft	38	38	38	38	38	38	38
Mound Height	D	Ft	2	2	2	2	2	2	2
	E	Ft	2	2.2	2.4	2.6	2.8	3.0	3.2
	F	Ft	.75	.75	.75	.75	.75	.75	.75
	G	Ft	1	1	1	1	1	1	1
	H	Ft	1.5	1.5	1.5	1.5	1.5	1.5	1.5
Mound Width	J	Ft	12	11	10	10	9	9	9
	I	Ft	12	13	14	17	18	21	26
	W	Ft	34	34	34	37	37	41	45
Mound Length	K	Ft	12	12	12	13	13	13	15
	L	Ft	62	62	62	64	64	64	68
Lateral Length	P	Ft	18.5	18.5	18.5	18.5	18.5	18.5	18.5
Lateral Diameter	-	In	1	1	1	1	1	1	1
No. of Laterals	-	-	6	6	6	6	6	6	6
Lateral Spacing	S	Ft	3	3	3	3	3	3	3
No. of Holes per Lateral ¹	-	-	8	8	8	8	8	8	8
Hole Spacing ¹	-	In	30	30	30	30	30	30	30
Hole Diameter	-	In	1/4	1/4	1/4	1/4	1/4	1/4	1/4
Manifold Length	R	Ft	6	6	6	6	6	6	6
Manifold Diameter ²	-	In	2	2	2	2	2	2	2

¹ Last hole is located at end of lateral which is 27" from previous hole.

² Diameter dependent upon size of pipe from pump and inlet position.

³ On steep sloping sites of 10-12% it may be desirable to reduce depth D to 1.5 ft so E isn't so great or reduce the width of bed.

⁴ Use a manifold with lateral only on one side.

⁵ Beds can be any desired width.

TABLE B-4. DESIGN CRITERIA FOR A 4 BEDROOM HOME FOR A MOUND ON 0 TO 12% SLOPE WITH LOADING RATES UP TO 600 GAL/DAY FOR SHALLOW PERMEABLE SOIL OVER CREVICED BEDROCK.

PARAMETER	SYMBOL	UNITS	PERCOLATION RATE MIN/IN						
			3-60				3-29		
Slope	-	%	0	2	4	6	8	10 ³	12 ³
Bed Width	A ⁵	Ft	10	10	10	10	10	10	10
Bed Length	B	Ft	50	50	50	50	50	50	50
Mound Height	D	Ft	2	2	2	2	2	2	2
	E	Ft	2	2.2	2.4	2.6	2.8	3.0	3.2
	F	Ft	.75	.75	.75	.75	.75	.75	.75
	G	Ft	1	1	1	1	1	1	1
	H	Ft	1.5	1.5	1.5	1.5	1.5	1.5	1.5
Mound Width	J	Ft	12	11	10	10	9	9	9
	I	Ft	12	13	14	17	18	21	26
	W	Ft	34	34	34	37	37	41	45
Mound Length	K	Ft	12	12	12	13	13	13	15
	L	Ft	74	74	74	76	76	76	78
Lateral Length	P ²	Ft	24.5	24.5	24.5	24.5	24.5	24.5	24.5
Lateral Diameter	-	In	1	1	1	1	1	1	1
No. of Laterals	-	-	6	6	6	6	6	6	6
Lateral Spacing	S	Ft	3	3	3	3	3	3	3
No. of Holes per Lateral ¹	-	-	10	10	10	10	10	10	10
Hole Spacing ¹	-	In	30	30	30	30	30	30	30
Hole Diameter	-	In	1/4	1/4	1/4	1/4	1/4	1/4	1/4
Manifold Length	R	Ft	6	6	6	6	6	6	6
Manifold Diameter ²	-	In	2	2	2	2	2	2	2

¹ End of lateral is 9" from last hole; since it isn't equal to or greater than 15, no hole is placed at end of lateral.

² Diameter dependent upon size of pipe from pump and inlet position.

³ On steep sloping sites of 10-12% it may be desirable to reduce depth D to 1.5 ft so E isn't so great or reduce the width of bed.

⁴ Use a manifold with lateral only on one side.

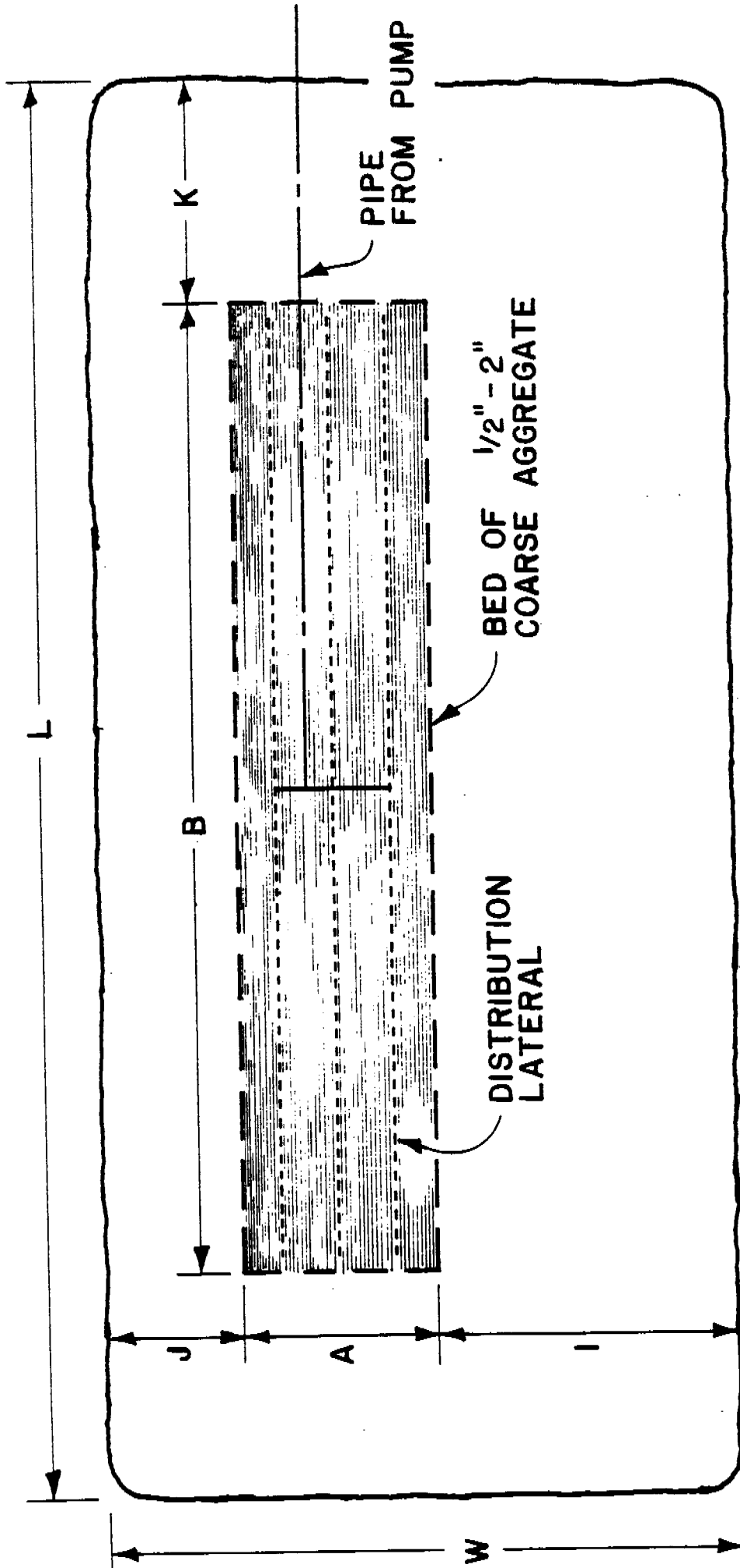

Fig. B. 1 Plan view of a mound using a bed for the absorption area. For the creviced bedrock site, the bed slope can be rectangular or square.

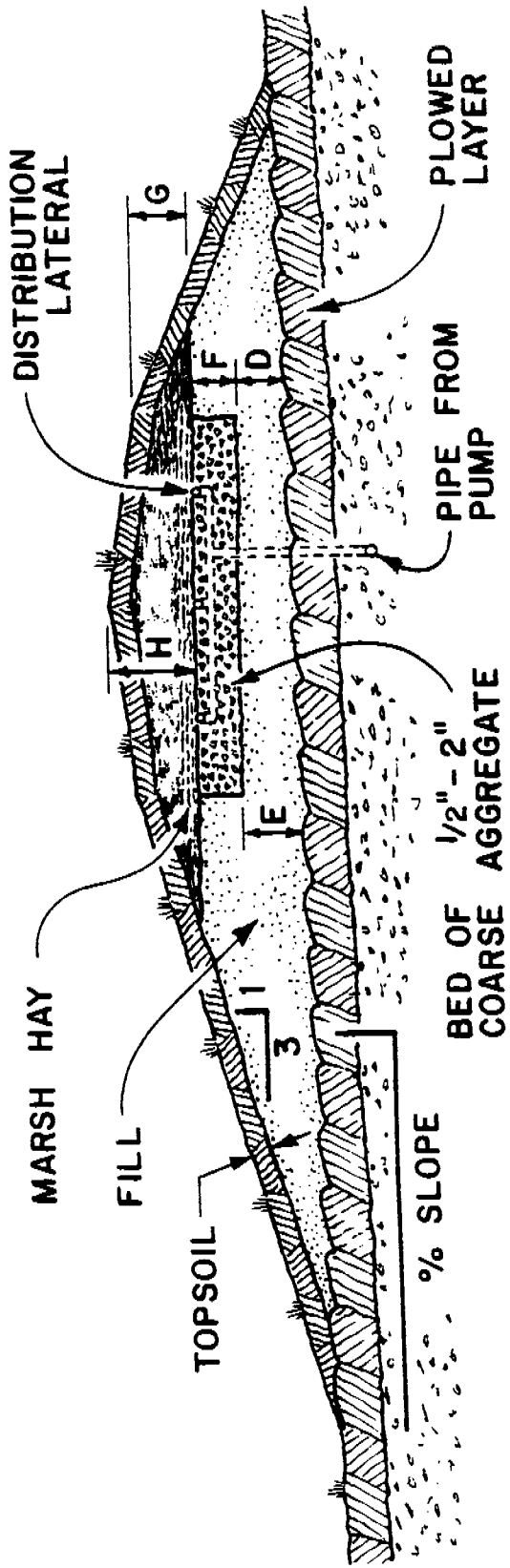
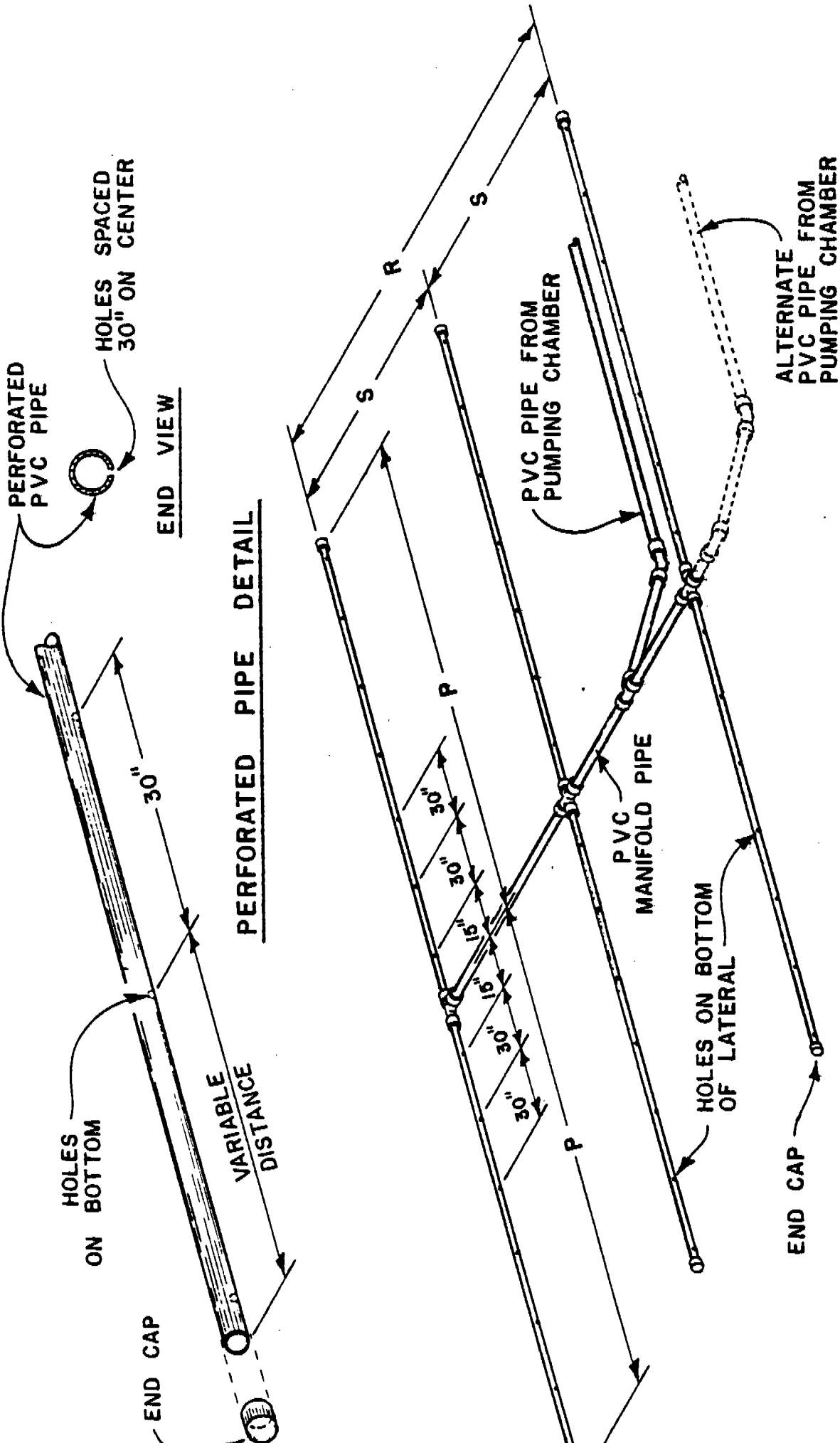

FIG. B. 2 Cross section of a mound using a bed as the absorption area.



PIPE LATERAL LAYOUT

Fig. B. 3 The distribution system for a mound. One lateral is placed down the center of each trench as shown on plan views. Note alternate inlet positions. The variable distance between the last hole and the next to last hole will range between 15 and 30 in., depending upon the length of trench. Distribution system must be arranged to manifold and laterals drain after each dose.

DESIGN EXAMPLE AND PLANS
for
MOUND
on
PERMEABLE SOIL WITH HIGH WATER TABLE

DESIGN EXAMPLE
for
MOUND
on
PERMEABLE SOIL WITH HIGH WATER TABLE

An example is used to illustrate the design procedure. The method outlined in the text is followed step by step for a situation commonly found in practice. Example plans have also been prepared for most site conditions encountered and are included following the design example. These prepared plans may be used where similar site conditions exist. In cases where these plans cannot be adapted to the site, a mound may be designed as illustrated below.

Design a mound system for a 3 bedroom home with the following site conditions. Several small trees are on the site. Rock fragments, impermeable layer and bedrock are not a factor. (Letter Notation on Fig. C.1 and C.3 are used as references in this example).

Slope	6%
Percolation Rate	50 min/in. at 24 in.
Ground Water	24 in.

Step 1. Select the Site

The mound site should be selected prior to house location and road building. Consider all criteria listed in Table 1 and the discussion under the "Soil and Site Requirement" section for all possible locations on the lot. Consider the difficulties in construction of the mound at the various locations. Evaluate all criteria, weigh one site against the other, then pick the best site.

Step 2. Waste Water Load

Design loading is 150 gal/day/bedroom, so with 3 bedrooms the design loading is 450 gal/day.

Step 3. Select the Fill Material

Select a medium sand texture. Use Table 2 as a guide. Sometimes it is necessary to make a judgement on the quality of sand versus the transportation costs, but there are sands which are too coarse or too fine that are not acceptable. A medium sand texture will have a design infiltration rate of 1.2 gal/ft²/day.

Step 4. Size the Absorption Area

Since the medium sand texture is being used, the infiltration rate is 1.2 gal/ft²/day.

Absorption area required = $450 \text{ gal/day} \div 1.2 \text{ gal/ft}^2/\text{day} = 375 \text{ ft}^2$.

Since this is a permeable soil with high ground water, a bed system can be used. Maximum bed widths are 10 ft. Since the soil percolation rate is 50 min/in. (indicating heavier soil) and situated on a slope, it is desirable to make the bed longer and narrower. This will spread the liquid along the slope. Some lateral movement of liquid will occur, since it is a heavier soil. By making it longer and narrower, it will reduce the possibility of seepage out the toe.

Use a bed width of 8 ft. (A) then:

bed length (B) = $375 \text{ ft}^2 \div 8 \text{ ft.} = 47 \text{ ft.}$

Step 5. Mound Height

Fill depth (D) = 1 ft. (min. fill depth beneath absorption area)

Fill depth (E) = D + slope (C+A)
 = 1 ft. + .06 (8) ft.
 = 1 ft. + .5
 = 1.5 ft. (this is approximate as bed must be at same elevation)

Bed depth (F) = 0.75 ft. minimum depth with a minimum of 0.5 ft. of aggregate below distribution system.

Cap and top soil depth (H) = 1.5 ft. which include 1 ft. of subsoil and 0.5 ft. of top soil

Cap and top soil depth (G) = 1.0 ft. which include 0.5 ft. of subsoil and 0.5 ft. of top soil.

Step 6. Mound Length and Width

End Slopes (K) = mound depth at center x 3:1 slope.
 = $(D+E) \div 2 + F+H) \times 3$
 = 3.5 ft. x 3
 = 10 ft.

Upslope Width (J) = mound depth at upslope edge x 3:1 slope x slope correction (Table 3).
 = $(D+F+G) \times 3 \times 0.85$
 = 2.8 ft. x 3 x 0.85
 = 8 ft.

Downslope Width (I) = mound depth at downslope edge x 3:1 slope x slope correction (Table 3).
 = $(E+F+G) \times 3 \times 1.22$
 = 3.3 ft. x 3 x 1.22
 = 13 ft.

$$\begin{aligned} \text{Mound Length (L)} &= B + 2 K \\ &= 47 \text{ ft.} + 2 \times 10 \text{ ft.} \\ &= 67 \text{ ft.} \end{aligned}$$

$$\begin{aligned} \text{Mound Width (W)} &= I + A + K \\ &= 13 + 8 + 8 \\ &= 29 \text{ ft.} \end{aligned}$$

Step 7. Basal Area

On sloping sites the basal area is that area under and downslope of the bed ($B \times (A+I)$). On level sites it is the total area under the mound ($B \times W$) except for end areas. The design loading rate of the soil with percolation rate of 50 min/in. is $0.74 \text{ gal/ft}^2/\text{day}$.

$$\begin{aligned} \text{Basal Area Required} &= \text{daily flow} \div \text{infiltrative capacity of soil} \\ &= 450 \text{ gal/day} \div 0.74 \text{ gal/ft}^2\text{day} \\ &= 608 \text{ ft}^2 \end{aligned}$$

$$\begin{aligned} \text{Basal Area Available} &= B \times (A+I) \\ &= 47 \text{ ft.} \times (8 + 13)\text{ft.} \\ &= 987 \text{ ft}^2 \end{aligned}$$

Sufficient area is available. If it were not, then the downslope width (I) would be increased until sufficient area is available.

Step 8. Distribution System

Fig. 11 and C. 3 shows typical examples of a distribution system. Design requires selection of hole spacing and diameter, lateral diameter and spacing, manifold length and diameter. Lateral length is defined as the distance from manifold (supply end) to far (distal) end. Tee to Tee construction is preferred. For systems larger than 5 bedroom residential, procedure outlined by Otis et al. (1978) must be used.

Hole spacing = 30 in.
Hole diameter = 1/4-in.

Lateral length -

Lateral lengths normally are about 0.5 feet shorter than one-half the length of bed. In this example, lateral length would be 23 ft. ($47 \div 2 - .5$)

Hole spacing -

Holes are spaced 30 in. apart.

The following are hole spacing distances in inches from the manifold to distal end of lateral. There are 10 holes per lateral.

15, 45, 75, 105, 135, 165, 195, 225, 255, 276*

*If the last hole, based on 30 in. spacing, is equal to or greater than 15 in. from the end of the lateral, put another hole in the end cap or close to it.

Lateral Diameter

Lateral diameters are dependent upon lateral length, hole size and spacing. Table 4 gives maximum allowable length for various hole diameters and hole spacings. For the 30 in. spacing and 1/4 in. hole, allowable lateral lengths for 1 in. diameter is 25 ft. and for 1 1/4 in. diameter is 38 ft. Since lateral length required is 23 ft., lateral diameter of 1 in. is satisfactory.

Lateral Spacing

Bed width is 8 ft. For 3 laterals on each side of manifold, the lateral spacing is 32 in. This gives 16 in. from lateral to edge of bed.

Manifold Length

Manifold length is distance between the outside laterals or summation of all lateral spacings. For this example, it would be 64 in.

Manifold Diameter

For these mound systems, the manifold diameter is normally 2 or 3-in., depending on the size of the pipe from the pumping chamber to the mound and the inlet location. The inlet can be in the side of the manifold between the laterals, (Fig. 11 or C.3), or it can be in the end of the manifold, preferably on the upslope edge. In either case, the manifold must slope toward the inlet so it will drain. For either inlet location the manifold can be 2-in. diameter if the pipe is 2-in. diameter. If the pipe from the pump is 3-in. diameter, and the inlet is in the end, then the manifold must be 3-in. diameter. If the inlet is in the side, then the manifold can be 2-in. diameter. For larger systems (greater than 5 bedroom), friction losses in manifold must be considered..

Step 9. Pumping Chamber Size

Table 7 gives the recommended pumping chamber size which is 750 gal. capacity. The features shown in Fig.12 should be incorporated into it.

Step 10. Pump Size

Assume the pumping chamber is located 75 ft. from the mound center and the elevation difference is 9 ft. from the pump to the lateral invert.

Pump Capacity

Using the recommended pressure of 2 ft. at the distal end of the lateral, Table 8 gives the pump capacity of 54 gpm for 1/4-in. diameter holes for a 3 bedroom sized mound. Fig.13 can be used to determine flow rate for other pressures.

Pump Head

The total head consists of (1) elevation difference, (2) friction loss, and (3) desired pressure at end of laterals.

(1) elevation head = 9 ft.

(2) friction loss -

Friction loss is dependent upon flow rate and pipe diameter.

Table 9 gives the friction loss/100 ft. of pipe for various diameter pipes and flow rates. For flow rate of 54 gpm, the friction loss for:

(a) 2-in. diameter is 3.98 ft/100 ft. x 75 ft. = 3.0 ft.

(b) 3-in. diameter is .67 ft/100 ft. x 75 ft. = .5 ft.

Either pipe can be used. Ignore friction losses for fittings. Manifold friction loss can be estimated by adding its length to the pipe length when figuring friction loss.

(3) Pressure at distal end of lateral

Fig. 13 can be used to determine pressure at supply end of lateral. For a 2 ft. pressure at distal end for 1/4-in. diameter holes, the pressure at supply end is 2.5 ft.

Total Head = 9 ft. + 3 ft. + 2.5 ft. = 14.5 ft. for 2 in.
diameter pipe.
= 9 ft. + .5 ft. + 2.5 ft. = 12 ft. for 3-in.
diameter pipe.

Pump size

Select a pump which would pump at least 54 gpm at 14.5 ft. of head. This given head loss is based on using 2 in. pipe. The pump opening will be smaller

or

Select a pump which would pump at least 54 gpm at 12 ft. of head. This given head loss is based on using a 3 in. pipe. The pump opening will be smaller.

Step 11. Dosing Quantity

From Table 5 the net recommended dosing quantity is 115 gal/dose. The void volume of the laterals needs to be checked to see if the dosing quantity is 10 times the void volume. From Table 6 the void volume of 1 in. diameter pipe is .041 gal/ft. For 138 feet of lateral, the void volume is 5.6 gal. which, when multiplied by 10, is less quantity given in Table 5. Therefore, the volume is 115 gal/dose. Adjustments need to be made for flow-back, so 115 gal. is actually dosed. For a 5-ft. diameter pumping chamber, the net liquid level differential per dose cycle is 9.4 in.

Step 12. Select the controls which will give the flexibility necessary for the proper quantity per dose (Fig. 14).

TABLE C-1. DESIGN CRITERIA FOR A MOUND FOR A 1 BEDROOM HOME ON 0-12% SLOPE FOR LOADING RATES OF 150 GAL/DAY FOR PERMEABLE SOIL WITH HIGH WATER TABLE. FIG. C.1 and C.2.

PARAMETER	SYMBOL	UNITS	PERCOLATION RATE MIN/IN						
			3-60			3-29			
Slope	-	%	0	2	4	6	8	10	12
Bed Width	A	Ft	4	4	4	4	4	4	4
Bed Length	B	Ft	32	32	32	32	32	32	32
Mound Height	D	Ft	1	1	1	1	1	1	1
	E	Ft	1	1.1	1.2	1.2	1.3	1.4	1.5
	F	Ft.	0.75	0.75	0.75	0.75	0.75	0.75	0.75
	G	Ft	1	1	1	1	1	1	1
Mound Width	H	Ft	1.5	1.5	1.5	1.5	1.5	1.5	1.5
	J	Ft	9	9	8	8	7	7	6
	I	Ft	9	10	11	12	13	14	15
Mound Length	W	Ft	22	23	23	24	24	25	25
	K	Ft	10	10	10	10	10	11	11
Lateral Length	L	Ft	52	52	52	52	52	53	53
	P	Ft	15.5	15.5	15.5	15.5	15.5	15.5	15.5
Lateral Diameter	-	In	1	1	1	1	1	1	1
No. of Laterals	-	-	2	2	2	2	2	2	2
No. of Holes per Lateral*	-	-	7	7	7	7	7	7	7
Hole Spacing*	-	In	30	30	30	30	30	30	30
Hole Diameter	-	In	1/4	1/4	1/4	1/4	1/4	1/4	1/4

* Last hole is located at end of lateral which is 21" from previous hole.

TABLE C-2. DESIGN CRITERIA FOR A MOUND FOR A 2 BEDROOM HOME ON 0-12% SLOPE FOR LOADING RATES OF 300 GAL/DAY FOR PERMEABLE SOIL WITH HIGH WATER TABLE. FIG. C.1 and C.2.

PARAMETER	SYMBOL	UNITS	PERCOLATION RATE MIN/IN						
			3-60			3-29			
Slope	-	%	0	2	4	6	8	10	12
Bed Width	A	Ft	6	6	6	6	6	6	6
Bed Length	B	Ft	42	42	42	42	42	42	42
Mound Height	D	Ft	1	1	1	1	1	1	1
	E	Ft	1	1.1	1.2	1.4	1.5	1.6	1.8
	F	Ft	.75	.75	.75	.75	.75	.75	.75
	G	Ft	1	1	1	1	1	1	1
Mound Width	H	Ft	1.5	1.5	1.5	1.5	1.5	1.5	1.5
	J	Ft	9	9	8	8	7	7	6
	I	Ft	9	10	11	12	13	15	17
Mound Length	W	Ft	60	61	61	62	62	64	65
	K	Ft	10	10	10	10	10	11	11
Lateral Length	L	Ft	62	62	62	62	62	64	64
	P	Ft	20	20	20	20	20	20	20
Lateral Diameter	-	In	1	1	1	1	1	1	1
No. of Laterals	-	-	4	4	4	4	4	4	4
Lateral Spacings	S	Ft	3	3	3	3	3	3	3
No. of Holes per Lateral*	-	-	8	8	8	8	8	8	8
Hole Spacing*	-	In	30	30	30	30	30	30	30
Hole Diameter	-	In	1/4	1/4	1/4	1/4	1/4	1/4	1/4
Manifold Length	R	Ft	3	3	3	3	3	3	3
Manifold Diameter**	-	In	2	2	2	2	2	2	2

* Last hole is located at end of lateral which is 15" from previous hole.

** Diameter dependent upon size of pipe from pump and inlet position.

TABLE C-3. DESIGN CRITERIA FOR A MOUND FOR A 3 BEDROOM HOME ON 0-12% SLOPE FOR LOADING RATE OF 450 GAL/DAY FOR PERMEABLE SOIL WITH HIGH WATER TABLE. FIG. C. 1 and C.2.

PARAMETER	SYMBOL	UNITS	PERCOLATION RATE						
			0-60			3-29			
Slope			0	2	4	6	8	10	12
Bed Width	A	Ft	8	8	8	8	8	8	8
Bed Length	B	Ft	47	47	47	47	47	47	47
Mound Height	D	Ft	1	1	1	1	1	1	1
	E	Ft	1	1.2	1.3	1.5	1.6	1.8	2.0
	F	Ft	.75	.75	.75	.75	.75	.75	.75
	G	Ft	1	1	1	1	1	1	1
Mound Width	H	Ft	1.5	1.5	1.5	1.5	1.5	1.5	1.5
	J	Ft	9	9	8	8	7	7	6
	I	Ft	9	11	12	13	15	17	18
Mound Length	W	Ft	26	28	28	29	30	32	32
	K	Ft	10	10	10	10	11	11	12
Lateral Length	L	Ft	67	67	67	67	69	69	71
	P	Ft	23	23	23	23	23	23	23
Lateral Diameter	-	In	1	1	1	1	1	1	1
No. of Laterals	-	-	6	6	6	6	6	6	6
Lateral Spacing	S	In	32	32	32	32	32	32	32
No. of Holes per Lateral*	-	-	10	10	10	10	10	10	10
Hole Spacing *	-	In	30	30	30	30	30	30	30
Hole Diameter	-	In	1/4	1/4	1/4	1/4	1/4	1/4	1/4
Manifold Length	R	In	64	64	64	64	64	64	64
Manifold Diameter**	-	In	2	2	2	2	2	2	2

* Last hole is located at end of lateral which is 21" from previous hole.

** Diameter dependent upon size of pipe from pump to inlet position.

TABLE C-4. DESIGN CRITERIA FOR A MOUND FOR A 4 BEDROOM HOME ON 0-12% SLOPE FOR LOADING RATE OF 600 GAL/DAY FOR PERMEABLE SOIL WITH HIGH WATER TABLE. FIG. C. 1 and C.2.

PARAMETER	SYMBOL	UNITS	PERCOLATION RATE						
			0-60			3-29			
Slope	-	%	0	2	4	6	8	10	12
Bed Width	A	Ft	10	10	10	10	10	10	10
Bed Length	B	Ft	50	50	50	50	50	50	50
Mound Height	D	Ft	1	1	1	1	1	1	1
	E	Ft	1	1.2	1.4	1.6	1.8	2	2.2
	F	Ft	0.75	0.75	0.75	0.75	0.75	0.75	0.75
	G	Ft	1	1	1	1	1	1	1
	H	Ft	1.5	1.5	1.5	1.5	1.5	1.5	1.5
Mound Width	J	Ft	9	8	8	8	7	7	6
	I	Ft	9	11	13	14	17	18	19
	W	Ft	28	29	31	32	34	35	35
Mound Length	K	Ft	10	10	10	10	11	11	12
	L	Ft	70	70	70	70	72	72	74
Lateral Length	P	Ft	24.5	24.5	24.5	24.5	24.5	24.5	24.5
Lateral Diameter	-	In	1	1	1	1	1	1	1
No. of Laterals	-	-	6	6	6	6	6	6	6
Lateral Spacing	S	Ft	3	3	3	3	3	3	3
No. of Holes per Lateral*	-	-	10	10	10	10	10	10	10
Hole Spacing	-	In	30	30	30	30	30	30	30
Hole Diameter	-	In	1/4	1/4	1/4	1/4	1/4	1/4	1/4
Manifold Length	R	Ft	6	6	6	6	6	6	6
Manifold Diameter*	-	In	2	2	2	2	2	2	2

* End of lateral is 9 in. from last hole, since it isn't equal to or greater than 15, no hole is placed at end of lateral.

** Diameter dependent upon size of pipe from pump and inlet position

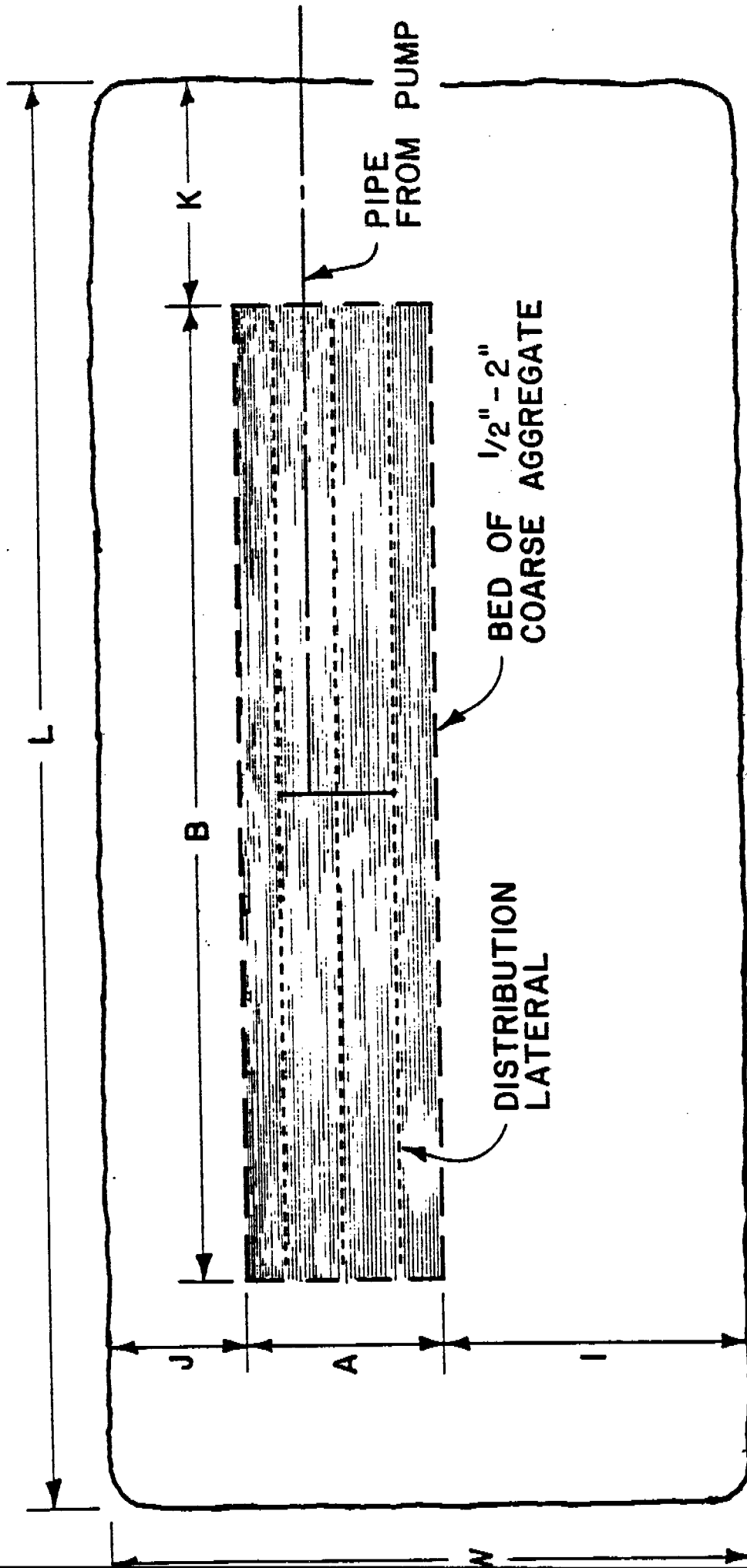

Fig. C.1 Plan view of mound using a bed for the absorption area. For the creviced bedrock site the bed slope can be rectangular or square,

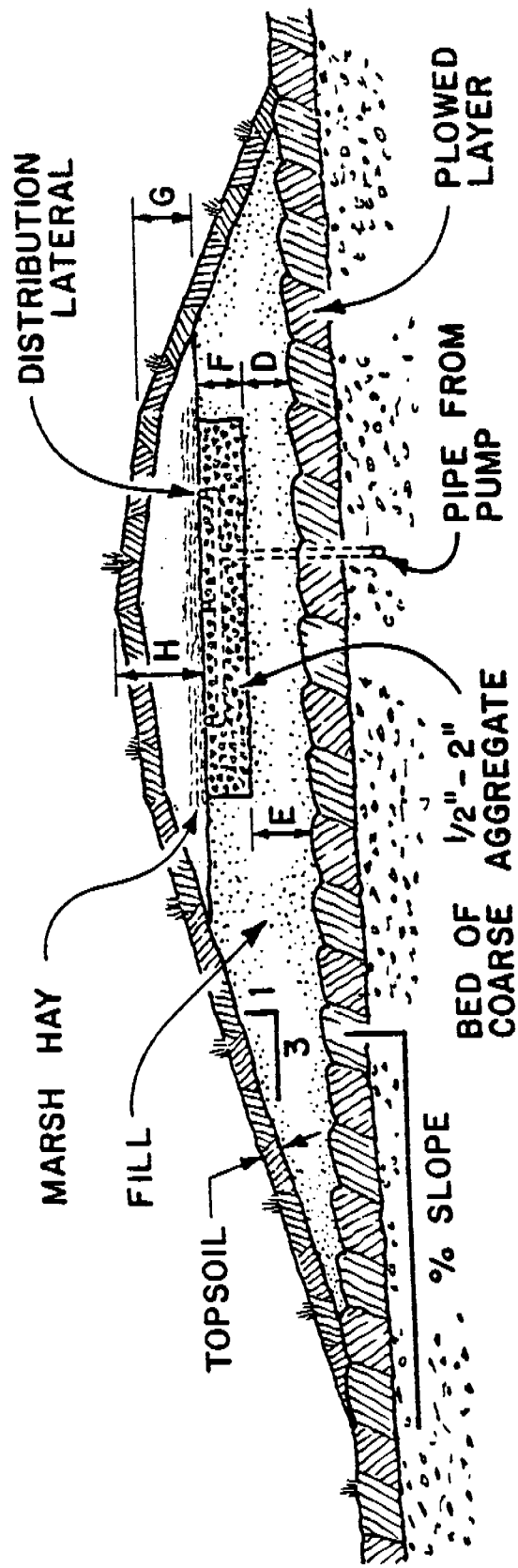
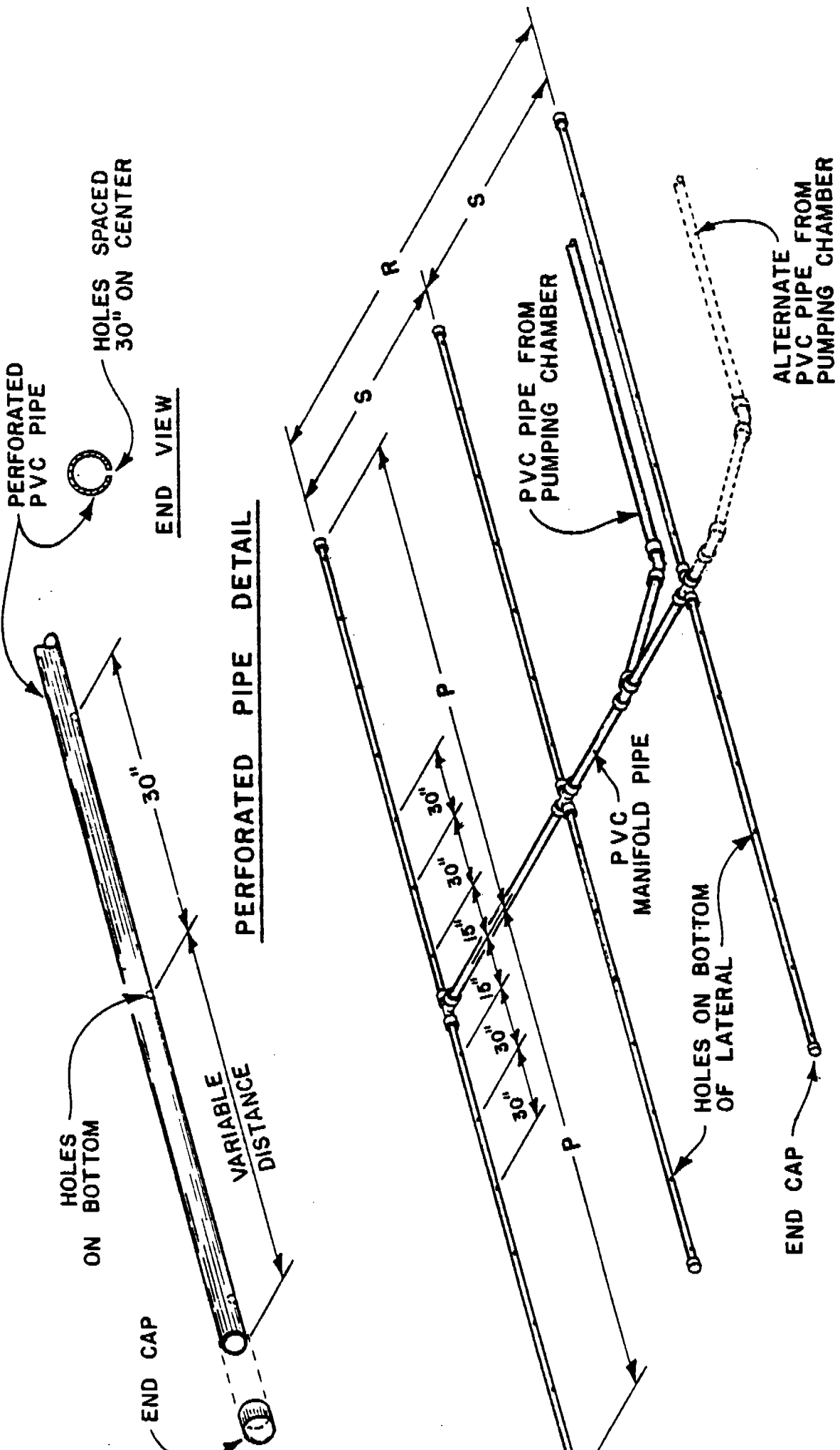

Fig. C. 2 Cross section of a mound using a bed as the absorption area.



PIPE LATERAL LAYOUT

Fig. C. 3 The distribution system for a mound system. For a mound with trenches, one lateral is placed down the center of each trench as shown on plan view, Note alternate inlet positions. The variable distance between the last hole and the next to last hole will range between 15 and 30 inches. This will vary depending upon the length of the trench, Distribution system must be arranged so that fold and laterals drain after each dose.

REFERENCES

- Bennett, E. R., K. D. Kinstedt, J. T. Felton. 1975. Rural Home Wastewater Characteristics. Home Sewage Disposal, ASAE Publication Proc. 175. St. Joseph, MI
- Bouma, J. 1975. Unsaturated flow during soil treatment of septic tank effluent. J. Environ. Engr. Div., ASCE, 101:E6, Proc. Paper 11783, pp. 967-983.
- Bouma, J., J. C. Converse, R. J. Otis, W. G. Walker and W. A. Ziebell. 1975. A mound system for on-site disposal of septic tank effluents in slowly permeable soils with seasonally perched water tables. J of Environ. Quality 4:382-388, No. 3
- Carlile, B. L., L. W. Stewart, M. D. Sobsey. 1977. Status of alternative systems for septic waste disposal in North Carolina. Proc. of 2nd Annual Illinois Private Sewage Disposal Symposium, Champaign.
- Converse, J. C. 1974. Distribution of domestic waste effluent in soil absorption beds, Trans. of ASAE 17:299-304.
- Converse, J. C., J. L. Anderson, W. A. Ziebell and J. Bouma. 1975. Pressure distribution of improving soil absorption systems. Home Sewage Disposal. ASAE Publication Proc. 175. St. Joseph, MI
- Converse, J. C., R. J. Otis, J. Bouma, W. G. Walker, J. L. Anderson and D. E. Stewart. 1975a. A design and construction procedure for mounds in slowly permeable soils with and without seasonally high water tables. Small Scale Waste Management Project., 1 Agriculture Hall, University of Wisconsin, Madison, WI
- Converse, J. C., R. J. Otis and J. Bouma. 1975b. Design and construction procedures for fill systems in permeable soils with shallow creviced bed-rock. Small Scale Waste Management Project., 1 Agriculture Hall, University of Wisconsin, Madison, WI
- Converse, J. C., R. J. Otis and J. Bouma. 1975c. Design and construction procedures for fill systems in permeable soils with high water tables. Small Scale Waste Management Project., 1 Agriculture Hall, University of Wisconsin, Madison, WI
- Converse, J. C., B. L. Carlile, G. W. Peterson. 1978. Mounds for the treatment and disposal of septic tank effluent. Home Sewage Treatment. ASAE Publication Proc. 5-77, St. Joseph, MI
- Machmeier, R. E. 1975. Design criteria for soil treatment systems. ASAE Paper 75-2577. ASAE., St. Joseph, MI
- Machmeier, R. E. 1977. Town and country sewage treatment. Bulletin 304. Agr. Extension Service, University of Minnesota, St. Paul.

- McCoy, E. and W. A. Ziebell. 1975. The effects of effluents on ground water: bacteriological aspects. Proceedings of the National Sanitation Foundation. 2nd National Conference on Individual On-site Wastewater Systems, Ann Arbor, MI
- Otis, R. J., J. Bouma, and W. G. Walker. 1974. Uniform distribution in soil absorption fields. Second National Groundwater, Special Issue No. 1 Proceedings of Second NWWA-EPA National Groundwater Quality Symposium, J. Tech Div. NWWA, pp. 409-417. Nov.-Dec.
- Otis, R. J., J. C. Converse, B. L. Carlile, J. E. Witty. 1978. Effluent distribution. Home Sewage Treatment. ASAE Publication 5-77 St. Joseph, MI
- Tyler, E. J., E. McCoy, R. Laak, S. S. Sandu. 1978. Soil as a treatment system, Home Sewage Treatment. ASAE Publication 5-77 St. Joseph, MI
- Witt, M., R. Sfegrist, W. C. Boyle. 1975. Rural household characteristics. Home Sewage Disposal ASAE Publication Proc. 175., St. Joseph, MI
- Witz, R. L. 1975. Twenty-five years with the North Dakota waste disposal system. Home Sewage Disposal. ASAE Publication Proc. 175. St. Joseph, MI
- Wooding, N. H. 1975. Alternate methods of effluent disposal for on lot home sewage systems. Bulletin of Cooperative Extension Service, College of Agriculture, Pennsylvania State University, University Park, PA

Board of Health
Interpretive Rule 16-1
Series

SECTION 4

Part VI

SEWAGE TANK CLEANING

Board of Health
Interpretive Rule 16-1
Series

Part VI
Sewage Tank Cleaning

INDEX

Subsection	Page
1.0 General.	
2.0 Motor Vehicle and Chassis.	
3.0 Carrier Tank	
4.0 Pumps and Hoses.	

Board of Health
Interpretive Rule 16-1
Series

1.0. General

1.1. Necessary hand tools such as picks and shovels, and other items such as sand and cement for repairing concrete sewage tanks shall be carried on the sewage tank cleaning vehicle.

1.2. All portable receptacles used for transporting the contents of sewage tanks shall be of approved construction, metal or equivalent, easily cleanable, good repair, equipped with tightfitting lids and shall be cleaned, deodorized and disinfected daily or more often if needed.

2.0. Motor Vehicle and Chassis

2.1. The motor vehicle and its chassis shall be of sufficient capacity to haul all equipment necessary for transporting, pumping, tank filling, emptying and cleaning of sewage tanks.

2.2. Sewage tank cleaning motor vehicles may be of one unit or of the tractor-trailer type, but regardless of the type, said motor vehicles shall be in compliance with all applicable provisions of these standards.

2.3. All vehicles used in these operations shall carry in a conspicuous place the name and address of the firm or operator under which business is conducted. All lettering shall be at least 2 inches in height.

3.0. Carrier Tank

3.1. Carrier tanks shall be fully enclosed, leakproof, fly-proof, and operated in such manner as to prevent spillage during the collection, removal, transportation, and disposal of the sewage tank contents.

3.2. Carrier tank shall be of heavy gauge metal, preferably 10-12 gauge or equivalent, to withstand the treatment to which it will be subjected.

Board of Health
Interpretive Rule 16-1
Series

3.2.1. The carrier tank shall have a capacity of at least 750 gallons, preferably 1000 gallons, to readily hold the accumulation of the average size sewage tank serving a one-family dwelling.

3.2.2. The capacity of the carrier tank, in gallons, shall be conspicuously painted on the side of said tank.

3.3. Carrier tanks shall be constructed so as to permit proper cleaning of the interior and exterior of the tank.

3.4. The exterior of the carrier tank shall be painted and said tank and appurtenances kept clean and in a state of good repair.

3.5. Carrier tanks shall be conspicuously and permanently labeled near the outlet valve in letters at least two inches high, "FOR SEWAGE ONLY," and said carrier tank shall not be used for any other purpose.

3.6. The health department permit number for the sewage tank cleaner shall be prominently displayed on the carrier tank.

3.7. Carrier tanks shall have a manhole in the top to provide for easy access to the tank interior for flushing and cleaning purposes. The manhole may be in combination with, or separate from, the filling connection.

3.8. The carrier tank shall have an outlet valve so located that the entire contents of the tank can be drained.

3.8.1. The outlet valve opening shall be at least three inches in diameter and shall have a non-leaking, non-clog type valve for draining the tank.

3.8.2. The outlet valve shall be adapted for a standard hose connection to the pump for recirculating the contents of the tank if required

Board of Health
Interpretive Rule 16-1
Series

prior to emptying or for pumping to the disposal site if gravity draining is not feasible.

3.8.3. In pumping from the carrier tank, an air inlet is recommended to prevent collapsing the tank.

3.8.4. Outlet valves shall be capped when not in actual use to prevent leaking or spilling of the carrier tank contents. Caps shall be secured by chain to outlet valve or tank.

3.9. Facilities shall be available for the flushing, cleaning and deodorizing of sewage tanks, carrier tanks, and sewage tank cleaning implements or equipment.

3.9.1. A direct connection to a water distribution system for such flushing or cleaning action shall only be used when the water distribution system is protected by one or more approved and properly located back-siphonage prevention devices.

3.9.2. Wastes resulting from the flushing or cleaning operation shall be disposed of in accordance with applicable provisions of these Design Standards.

3.9.3. Odor controlling substances may be left in the sewage tank, carrier tank or other sewage tank cleaning implement or equipment, but in no case shall such substances be used in lieu of proper cleaning.

4.0. Pumps and Hoses

4.1. All pumps used for sewage tank cleaning purposes shall be of the non-clog, self-priming type and shall be capable of handling the contents of sewage tanks.

4.2. The use of potable water under pressure to prime pumps or to

Board of Health
Interpretive Rule 16-1
Series

operate aspirators is prohibited.

4.3. Pumps and pump bases shall be of such construction that they can be easily handled and used for the purpose intended.

4.4. Hoses shall be of sufficient length for recirculating the contents of the sewage tank or carrier tank and to reach the point of discharge at the disposal site readily.

4.5. Hoses shall be flexible and so constructed that they can be readily cleaned.

4.5.1. Hoses shall be kept clean and in a good state of repair.

4.5.2. Hoses shall be used and stored in such manner as to prevent leaking, spilling, and dripping of any sewage tank contents.

4.5.3. When not in actual use hoses shall be tightly capped.

Board of Health
Interpretive Rule 16-1
Series

SECTION 4

Part VII

SEPTAGE TREATMENT AND DISPOSAL

Board of Health
Interpretive Rule 16-1
Series

Part VII

SEPTAGE TREATMENT AND DISPOSAL

INDEX

Subsection	Page
1.0 Public Sewage Treatment Plant	
2.0 Trenching	
3.0 Lagoons	
4.0 Lime Stabilization	
5.0 Other Methods	

Board of Health
Interpretive Rule 16-1
Series

1.0. Public Sewage Treatment Plant

1.1. Permission for disposal of septage must be granted to the septage hauler, in writing, by the owner and operator of the public sewage treatment plant.

1.2. Septage should not be disposed of in a public sewage treatment plant treating less than 100,000 gallons per day, unless pre-treatment is provided.

2.0. Trenching

2.1. Site Conditions

2.1.1. The soil conditions must be such that there would be a minimum of four (4) feet of soil between the bottom of the trench and the high ground water table and rock table for permeable soils and a minimum of the two (2) feet of soil between the bottom of the trench and the high groundwater table and rock table for impermeable clay soils.

2.1.2. The trench site must be free of rock outcroppings and must be out of the 25 year flood plain.

2.2. Construction

2.2.1. All surface water must be divided from the trenches and there is to be no discharge from the trenches.

2.2.2. The trenches shall not be located within 1,000 feet of any existing occupied buildings.

2.2.3. The trenches are to be enclosed by a six (6) foot high stock-proof fence with a locked entrance gate, or made inaccessible to the public through location on other means.

2.3. Operation

Board of Health
Interpretive Rule 16-1
Series

2.3.1. The septage is placed sequentially in one of many trenches in small lifts (6 to 8 inches) to minimize drying time.

2.3.2. When the trench is filled with septage, two (2) feet of soil must be placed as a final over, and new trenches opened. Sufficient room must be left between trenches for movement of heavy equipment.

3.0. Lagoons

3.1. Site Conditions

3.1.1. The soil conditions must be minimum of four (4) feet of soil between the bottom of the lagoon and the high groundwater table and rock table for permeable soils and a minimum of two (2) feet of soil, between the bottom of the lagoon and the high groundwater table and rock table for impermeable clay soils.

3.1.2. The lagoon site must be free of rock outcroppings and must be out of the 25 year flood plain.

3.2. Construction

3.2.1. All surface water must be divided from the lagoon and there is to be no discharge from the lagoon.

3.2.2. Maximum depth of the lagoon should be no greater than six (6) feet with one (1) foot freeboard.

3.2.3. Inside and outside slopes shall be no greater than 3 to 1 unless some type of side reinforcement is proposed (example: rip-rap).

3.2.4. The lagoon must be enclosed by a six (6) foot high fence with a locked entrance gate or made inaccessible to the public through location or other means.

3.2.5. The lagoon shall not be located within 1,000 feet of any

existing occupied buildings.

3.3. Operation

3.3.1. Disposal lagoons require placement of septage in small incremental lifts (6 to 12 inches) and sequential loading of another lagoon on lagoons for optimum drying. Therefore, as a minimum, two (2) lagoons are required.

3.3.2. When the lagoon is filled with septage and it is not to be used again, two (2) feet of soil must be placed at a final cover.

3.3.3. If the lagoon is to be re-used, the septage must be retained for a minimum of 90 days after the last load is discharged.

3.4. Disposal

3.4.1. After the minimum 90 day storage in the lagoons the septage may be land disposed, either by landfillings or land spreading.

3.4.2. Lagoon contents must be immediately covered after landfilling or land spreading.

3.4.3. Land spreading of lagoon contents on fields to be used for growing crops for human or animal consumption is generally not recommended due to the potentially high infectious nature of the waste. However, fields used for land spreading may be used for animal forage crops provided the fields are fallow for a minimum of six (6) months after the last application and prior to the first plantings of the forage crops.

4.0. Lime Stabilization

4.1. General

4.1.1. The addition of lime in sufficient quantities will stabilize septage and destroy pathogenic organisms. There is no destruction of organic matter or solids reduction during the lime stabilization process.

Board of Health
Interpretive Rule 16-1
Series

4.2. Operation

4.2.1. The septage and lime are to be mixed together until a pH greater than 12 is reached.

4.2.2. The mixture must be held at a pH greater than 12 for a minimum of two (2) hours.

4.2.3. Mixing can be accomplished through diffused air mixing or by mechanical mixers.

4.3. Land Disposal

4.3.1. The mixture can be land disposed following the requirements outlined in Section 3.4.2 and 3.4.3 above.

5.0. Other Methods

5.1. General

5.1.1. Other methods of septage treatment and disposal are composting, pressure chlorination, electron treatment, incineration and conventional waste treatment. These methods of septage treatment and disposal will have to be reviewed by the director on a case by case basis.

Board of Health
Interpretive Rule 16-1
Series

SECTION 4

Part VIII

ABANDONING SEWAGE SYSTEMS

Board of Health
Interpretive Rule 16-1
Series

INDEX

Subsection	Page
1.0 General.	
2.0 Electrical Service	
3.0 Water Service.	
4.0 Hazardous Equipment.	

Board of Health
Interpretive Rule 16-1
Series

1.0. General - The contents of the sewage tank shall be removed by a licensed septic tank cleaner, or by means approved by the director, the tank filled with earth or a similar inert material, and the excavation, if any, filled to eliminate any physical hazard. If the tank is in useable condition it may be removed and the excavation filled to eliminate any physical hazard.

2.0. Electrical Service - Any electrical service to the system shall be terminated, and electrical service boxes, switches, meters, and similar equipment, removed or rendered harmless.

3.0. Water Service - Any water service to the system shall be disconnected.

4.0. Hazardous Equipment - Any other potentially hazardous equipment associated with the system shall be removed or rendered harmless.

Section 5. Administrative Due Process - Those persons adversely affected by the enforcement of these interpretive rules desiring a contested case hearing to determine any rights, duties, interests or privileges shall do so in a manner prescribed in the West Virginia Procedural Rules, Board of Health, Chapter 16-1, Series I, 1981, Rules of Procedure for Contested Case Hearings and Declaratory Rulings. The aforementioned procedural rules are incorporated herein by reference.

Section 6. Severability - If any provisions of these rules or the application thereof to any person or circumstances shall be held invalid, such invalidity shall not affect the provisions or the application of these rules which can be given effect without the invalid provisions or application, and to this end the provisions of these rules are declared to be severable.

Board of Health
Interpretive Rule 16-1
Series

SECTION 4

PART IX

ANIMAL WASTE HANDLING FACILITIES

Board of Health
Interpretive Rule 16-1
Series

PART IX

ANIMAL WASTE HANDLING FACILITIES

INDEX

Subsection

Page

1.0 General

Board of Health
Interpretive Rule 16-1
Series

1.0. General - Animal waste handling facilities are to be designed and constructed in accordance with the current issue of the U.S. Department of Agriculture Soil Conservation Service. Agriculture Waste Management Field Manual.